

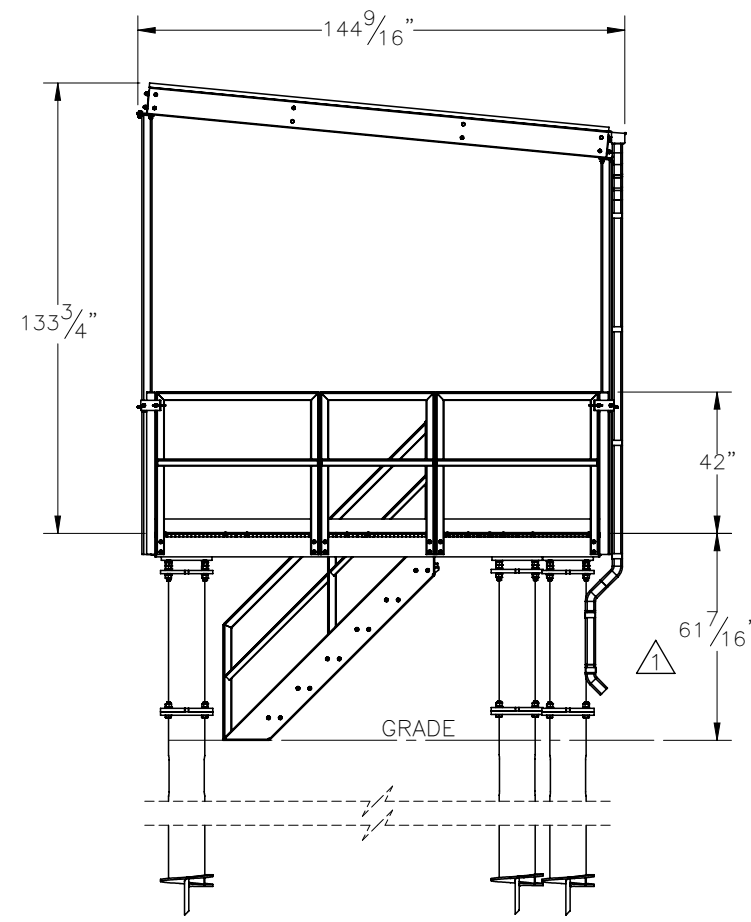

THE INFORMATION CONTAINED IN THIS DRAWING IS THE SOLE PROPERTY OF ELECTRO MECHANICAL INDUSTRIES, INC. ANY REPRODUCTION IN PART OR WHOLE WITHOUT THE WRITTEN PERMISSION OF ELECTRO MECHANICAL IND., IS PROHIBITED.

REVISIONS					
REV.	DCN #	DESCRIPTION	DATE	BY	APPROVED
1	01074	UPDATED TO NEW EMI STANDARDS	6/22/2022	BLH	JPB

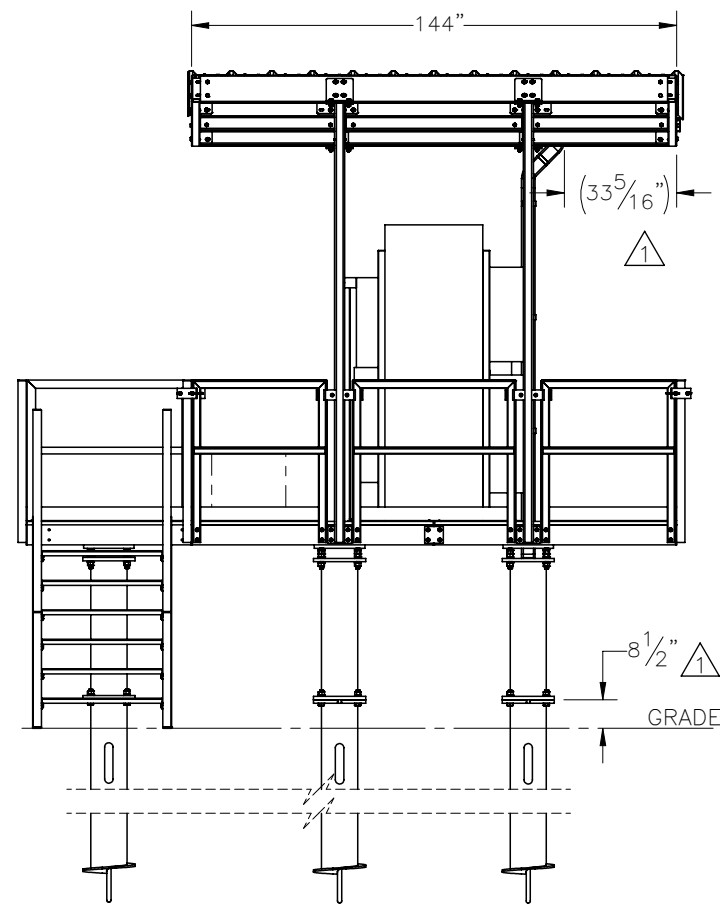
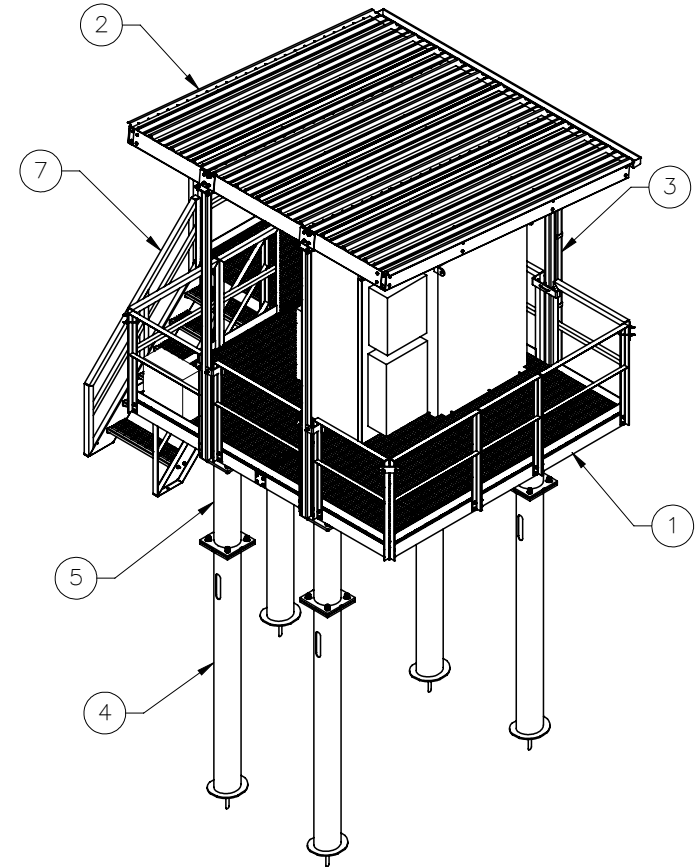
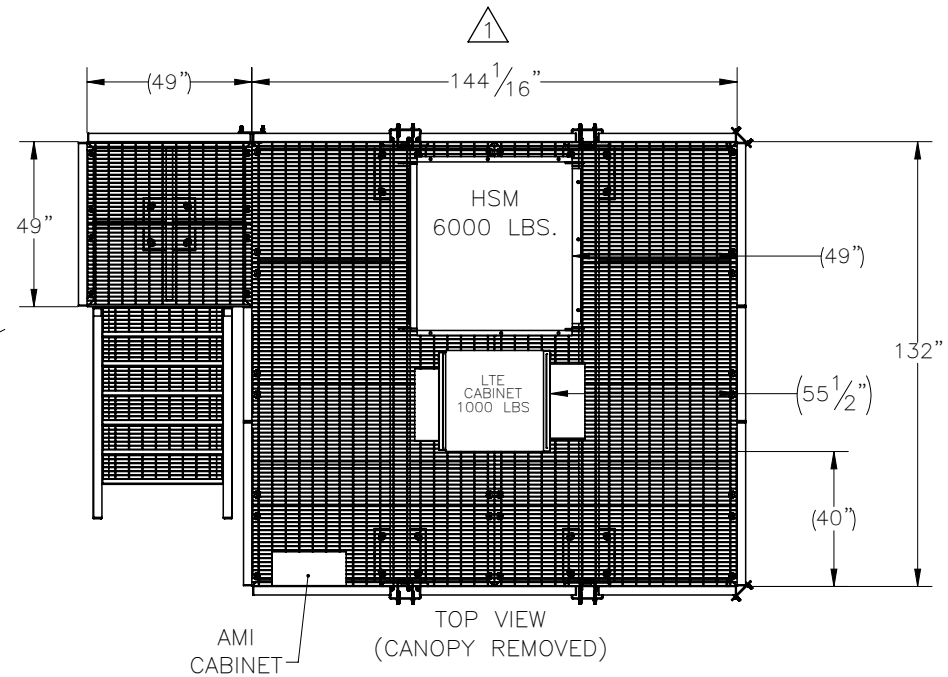
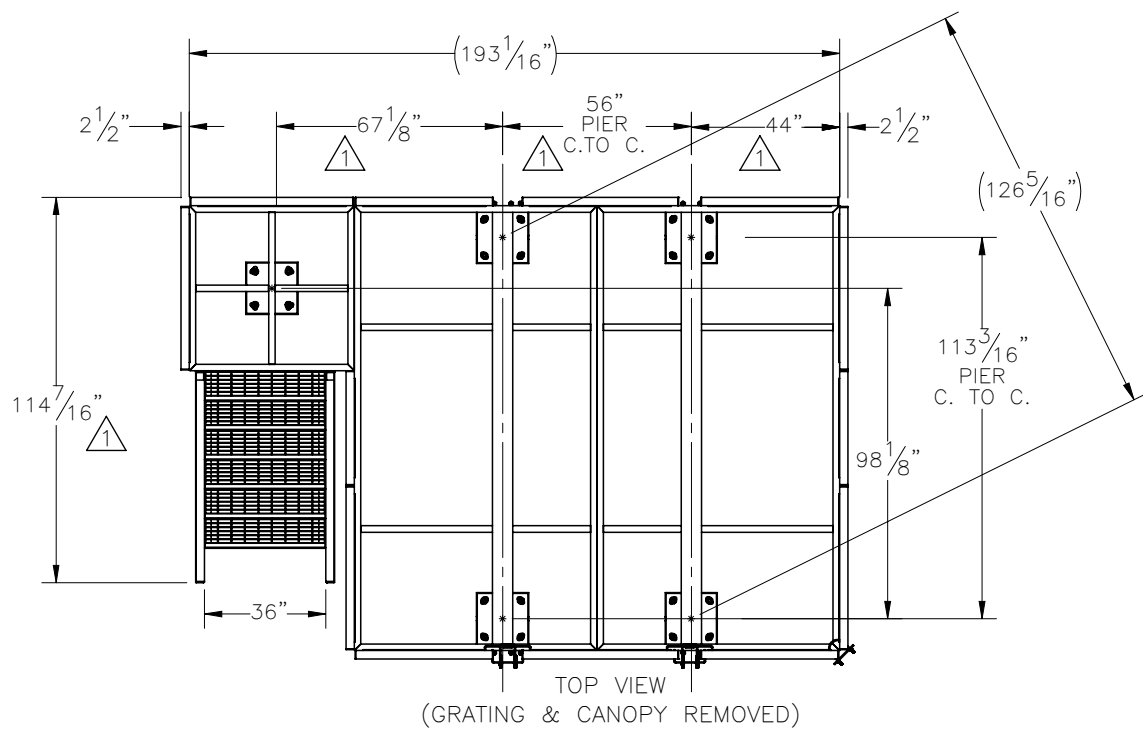

ITEM NO.	QTY REQD	PART NUMBER	DESCRIPTION	LENGTH	WEIGHT
1	1	1001-0020-0076	PLUG POWER PLATFORM ASSEMBLY		2288.1
2	1	1001-0030-0056	144" X 136.84" CANOPY ASSEMBLY		1103.6
3	1	A-000-324	GUTTER ASSEMBLY		77.4
4	5	400-000-1001	10" X 10", 1" BASE, 1" HDW. - HELICAL PIER		347
5	5	1007-T010-0420	3.5 FT EXTENSION		236.1
6	1	1003-0030-0005	49" STAIR LANDING		531.2
7	1	450-000-0142	6 TREAD STAIR ASS'Y (36" WIDE)		424.6
8	5	1004-T001-0484	HANDRAIL, 48.5	48 1/2"	72.36
9	4	1004-T001-0400	HANDRAIL, 40	40"	64.86
10	2	1004-T001-0340	HANDRAIL, 34	34"	59.57
11	4	A-000-116	POST BRACKET		11.1
12	3	A-000-117	CORNER BRACKET		2.6
13	1	A-000-118	HANDRAIL BRACKET		2.6
14	64	002-0BG-0010	HHB, .500-13 X 1.50 LG., PT X 1.00, A325, HDG	1.50	0.14
15	64	002-0FW-G002	FW, .50, F436, HDG		0.02
16	64	002-0LW-G002	WASHER, SPLIT LOCK, .500", GALV		0.01
17	64	002-0NG-0010	NUT, HEX, .500-13UNC, GR 2H, GALV		0.06

SURFACE FINISH <input checked="" type="checkbox"/> UNLESS OTHERWISE SPECIFIED		UNLESS OTHERWISE SPECIFIED DIMENSIONS ARE IN INCHES		APPROVALS		DATE		 ELECTRO MECHANICAL INDUSTRIES, INC. 11230 NEESESHAW DRIVE HOUSTON, TEXAS 77065 1-800-453-0050	
MATERIAL SEE PARTS LIST		TOLERANCES		DRAWN J. CRITELLI		7/24/2019		TITLE: PLUG POWER SOUTHERN PLATFORM 5' ELEVATION	
THIRD ANGLE PROJECTION		.0 ±.06 .00 ±.015 .000 ±.005		CHECKER R. WOODARD		7/26/2019		SIZE B	
NEXT ASSY USED ON		FRACTIONS ± 1/16 ANGLES ± .25°		ENGINEER J. BREEN		7/26/2019		DRAWING NO. 1000-0000-0130	
APPLICATIONS		HOLES: DRILLED OR PUNCHED ± 1/32 BURNED ± 1/32		PRODUCTION J. SUNDERLAND		7/26/2019		REV 1	
				SCALE: 1:57		WEIGHT: 8149.6 lbs.		SHEET 1 OF 4	

8 7 6 5 4 3 2 1

D

D

C

C

B

B

A

A

INSTALL GUTTER FLANGE
BETWEEN CANOPY FRAME
& ROOF PANELS

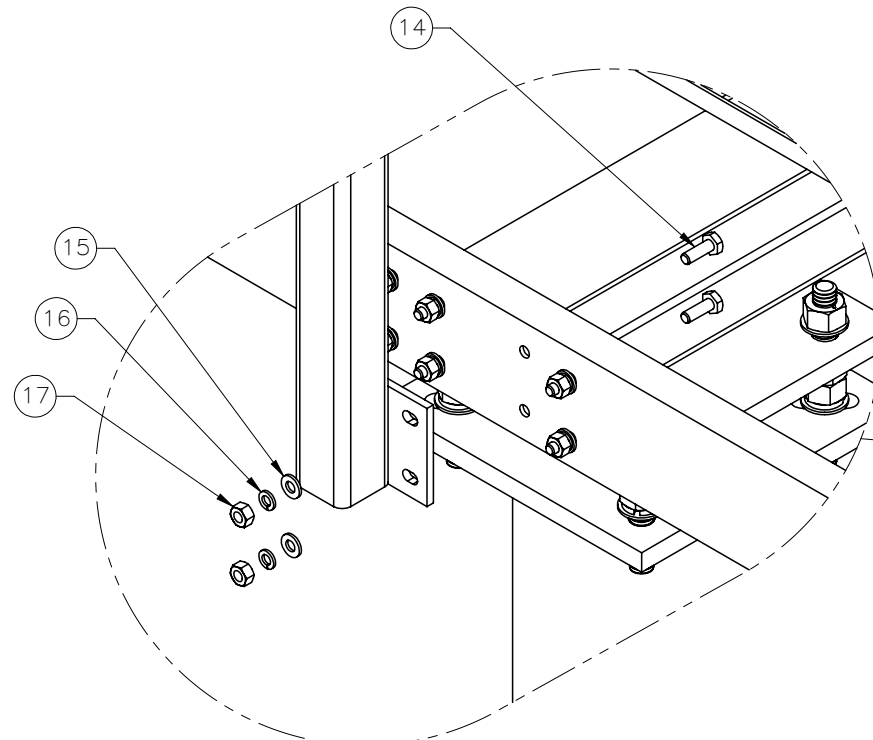
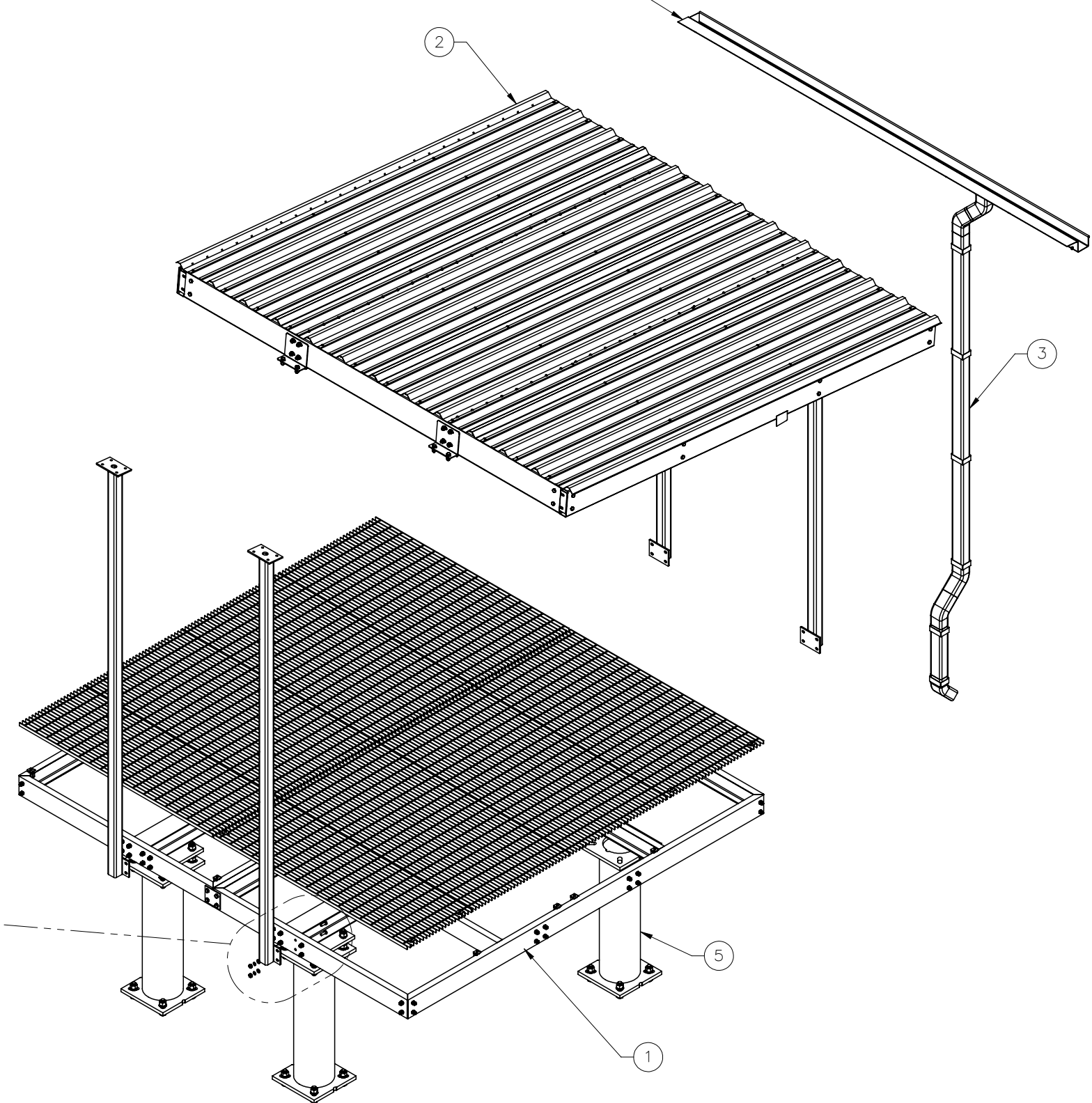

TYPICAL CANOPY
CONNECTION

		ELECTRO MECHANICAL INDUSTRIES, INC. 11230 NEESHAW DRIVE HOUSTON, TEXAS 77065 1-800-453-0050	
SIZE	DRAWING NO.	REV.	
B	1000-0000-0130	1	
SCALE: 1:35		SHEET 2 OF 4	

8 7 6 5 4 3 2 1

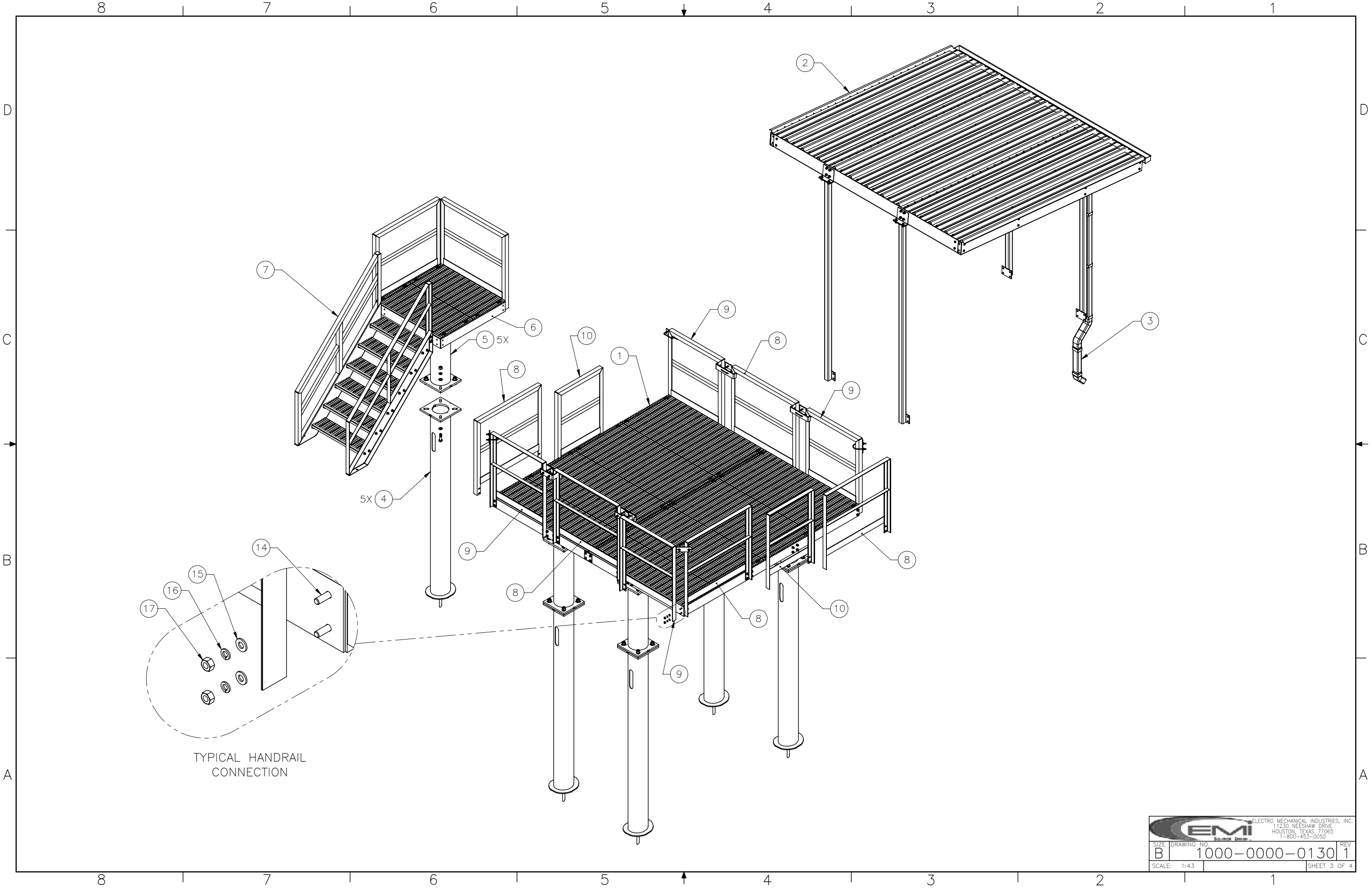

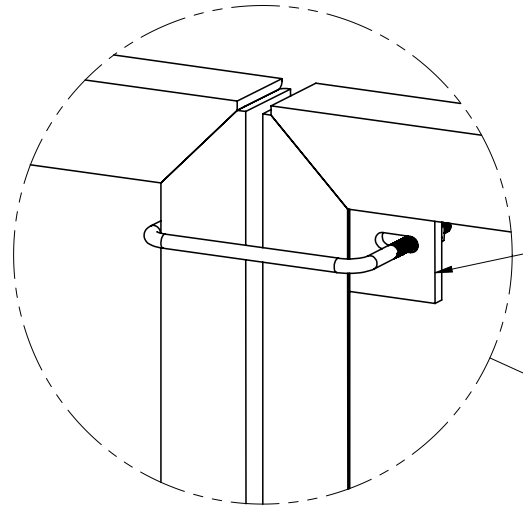

HANDRAIL BRACKET DETAIL
1X

13

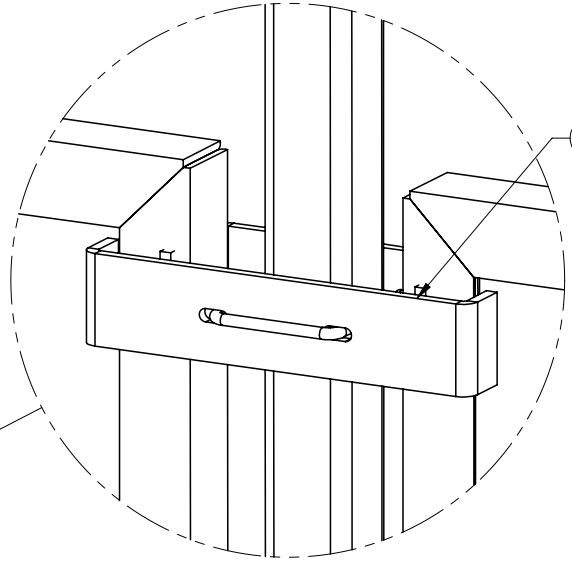

POST BRACKET DETAIL
TYP
4X

11

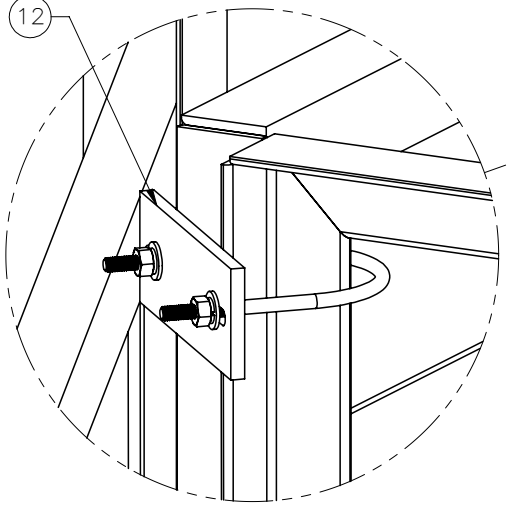

CORNER BRACKET DETAIL
TYP
3X

12

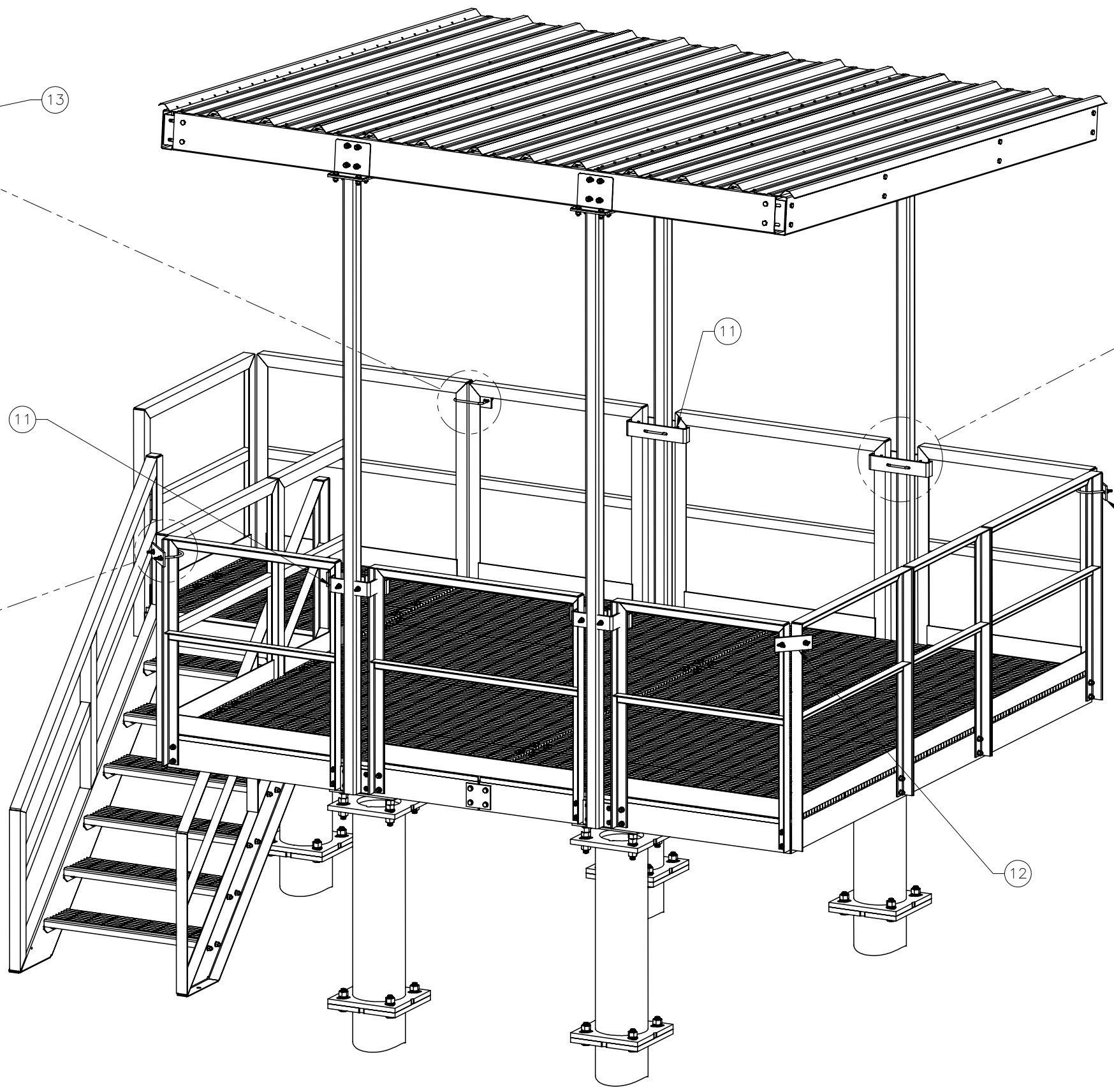

11

12

12

		ELECTRO MECHANICAL INDUSTRIES, INC. 11230 NEESHAW DRIVE HOUSTON, TEXAS 77065 1-800-453-0050	
SIZE	DRAWING NO.	REV.	
B	1000-0000-0130	1	
SCALE: 1:25		SHEET 4 OF 4	