

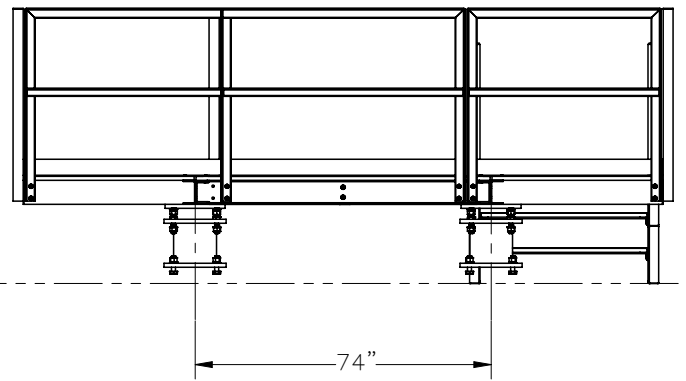

THE INFORMATION CONTAINED IN THIS DRAWING IS THE SOLE PROPERTY OF ELECTRO MECHANICAL INDUSTRIES, INC. ANY REPRODUCTION IN PART OR WHOLE WITHOUT THE WRITTEN PERMISSION OF ELECTRO MECHANICAL IND., IS PROHIBITED.

REVISIONS					
REV.	DCN #	DESCRIPTION	DATE	BY	APPROVED
1	01218	REMOVED 400-000-1001 QTY 4, NOTE ADDED TO FILL GAP UNDER EXTENSIONS.	02/13/2023	JTR	JPB

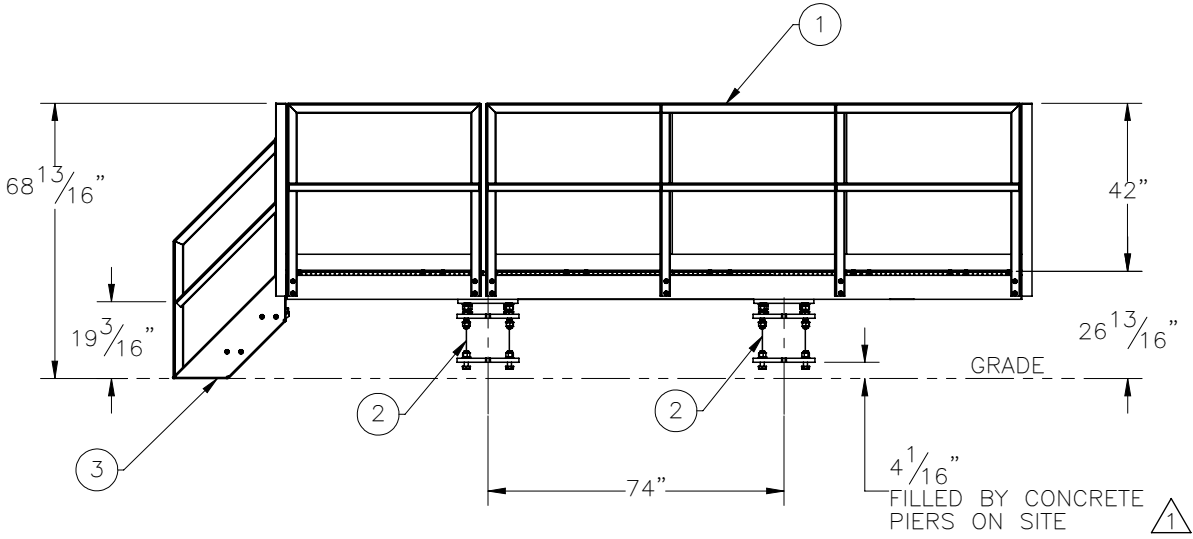
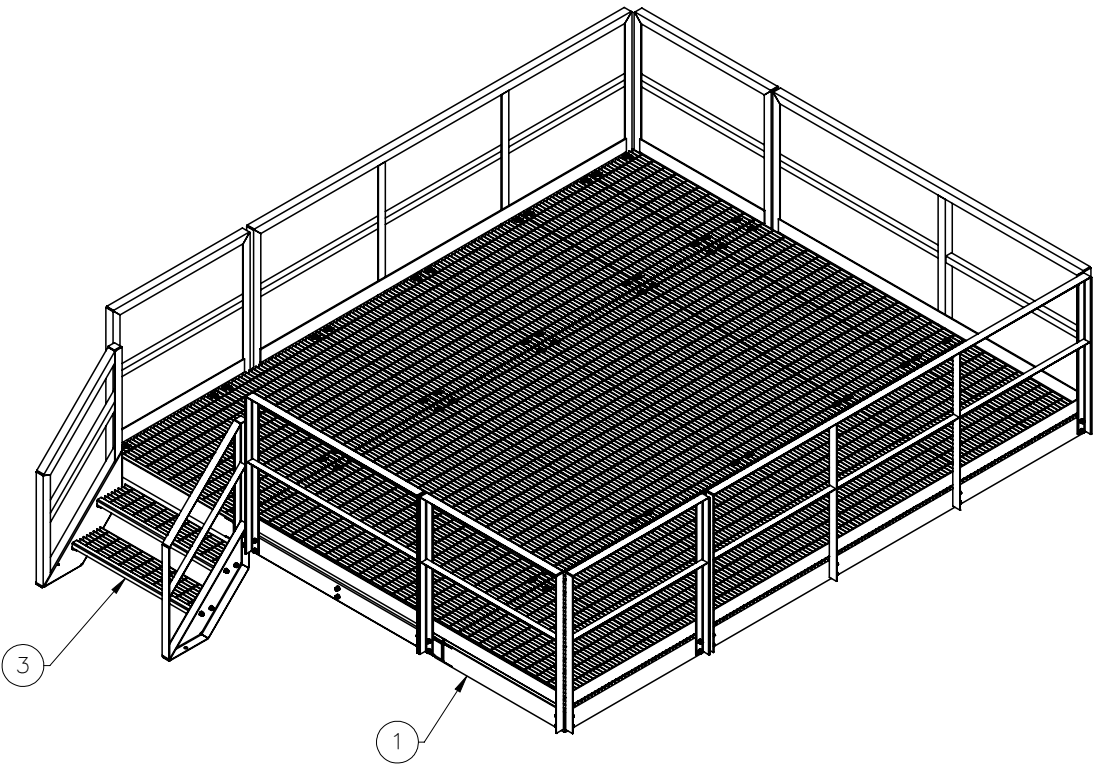
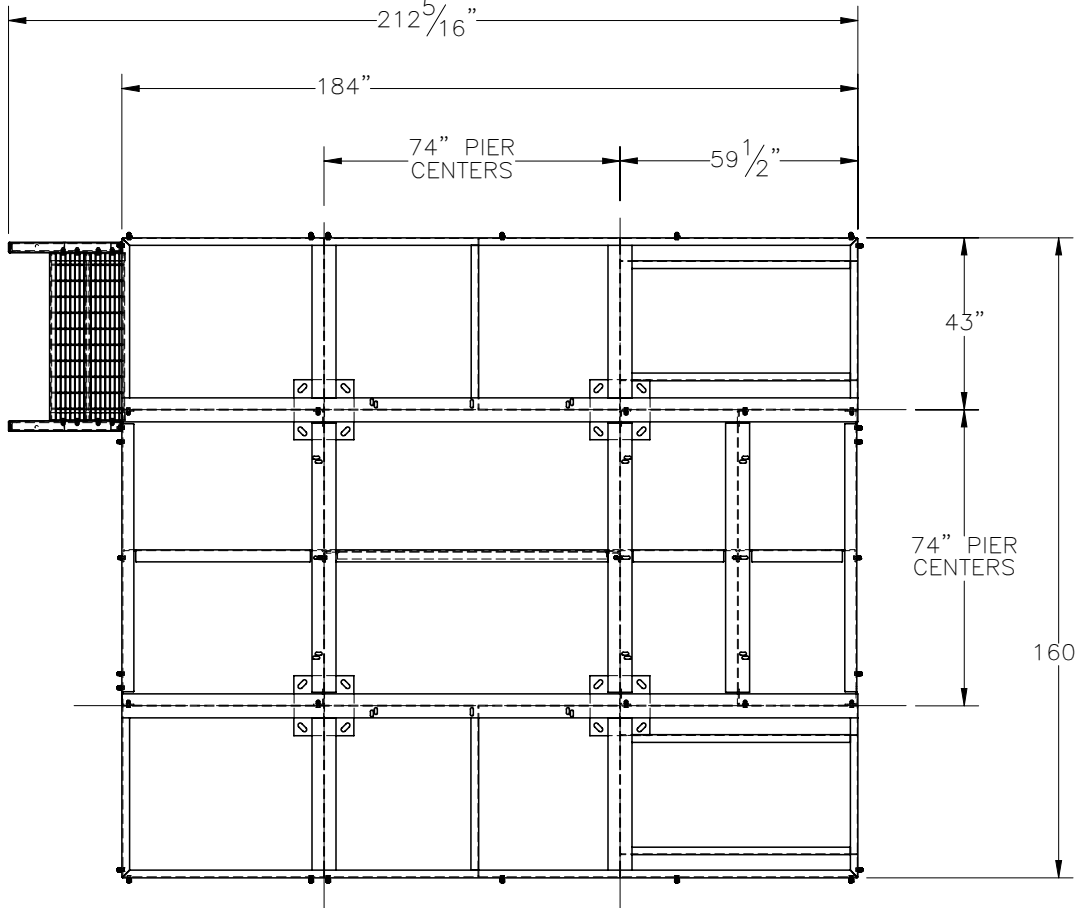

ITEM NO.	QTY REQD	PART NUMBER	DESCRIPTION	LENGTH	WEIGHT
1	1	1001-0020-0088	160" X 184" CABINET PLATFORM		4370
2	4	1007-T010-0120	1.0 FT EXTENSION		154.8
3	1	1003-0020-0006	2 TREAD STAIR ASSY (42" WIDE), HANDRAIL		188.9

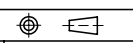
SURFACE FINISH <input checked="" type="checkbox"/> UNLESS OTHERWISE SPECIFIED		UNLESS OTHERWISE SPECIFIED DIMENSIONS ARE IN INCHES		APPROVALS		DATE		 ELECTRO MECHANICAL INDUSTRIES, INC. 11230 NEESESHAW DRIVE HOUSTON, TEXAS 77065 1-800-453-0050	
MATERIAL SEE PARTS LIST		TOLERANCES .0 ±.06 .00 ±.015 .000 ±.005 FRACTIONS ± 1/16 ANGLES ±.25° HOLES: DRILLED OR PUNCHED ±1/32 BURNED ±1/32		DRAWN J. ROACH		1/27/2023			
THIRD ANGLE PROJECTION 		NEXT ASSY USED ON		CHECKER J. Breen		1/30/2023		SIZE B DRAWING NO. 1000-0000-0226 REV 1 SCALE: 1:4 WEIGHT: 5097 lbs. SHEET 1 OF 1	
APPLICATIONS				ENGINEER J. Breen		1/30/2023			