

THE INFORMATION CONTAINED IN THIS DRAWING IS THE SOLE PROPERTY OF ELECTRO MECHANICAL INDUSTRIES, INC. ANY REPRODUCTION IN PART OR WHOLE WITHOUT THE WRITTEN PERMISSION OF ELECTRO MECHANICAL IND., IS PROHIBITED.

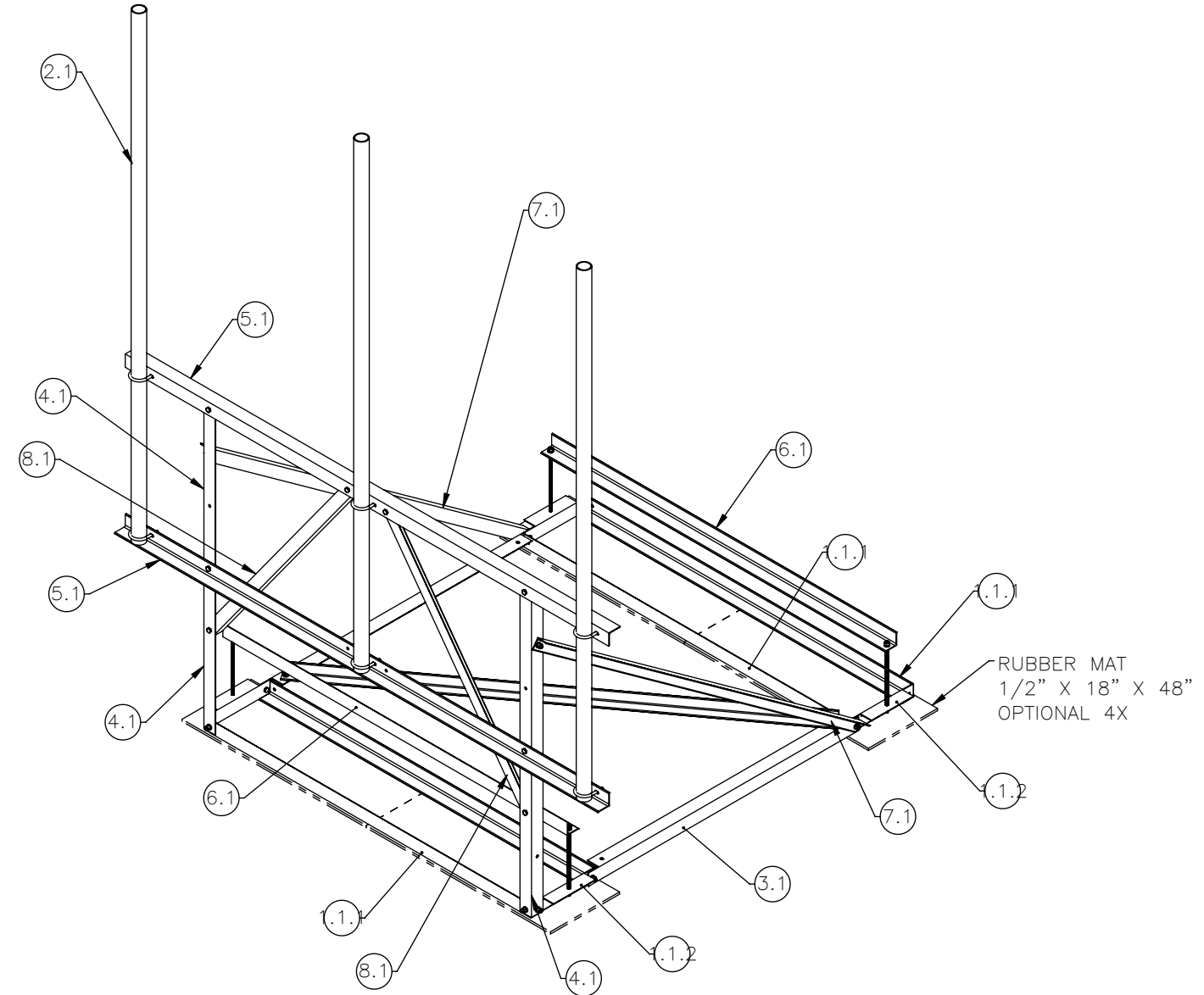
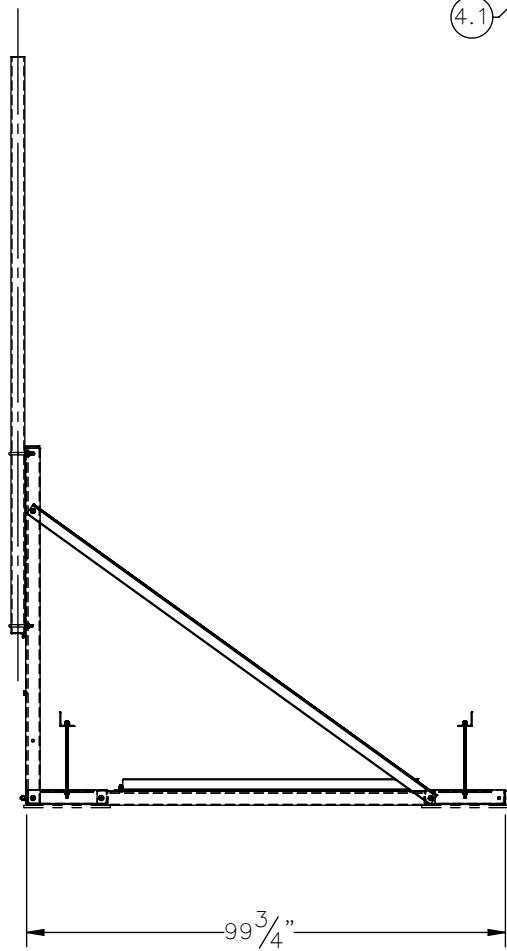
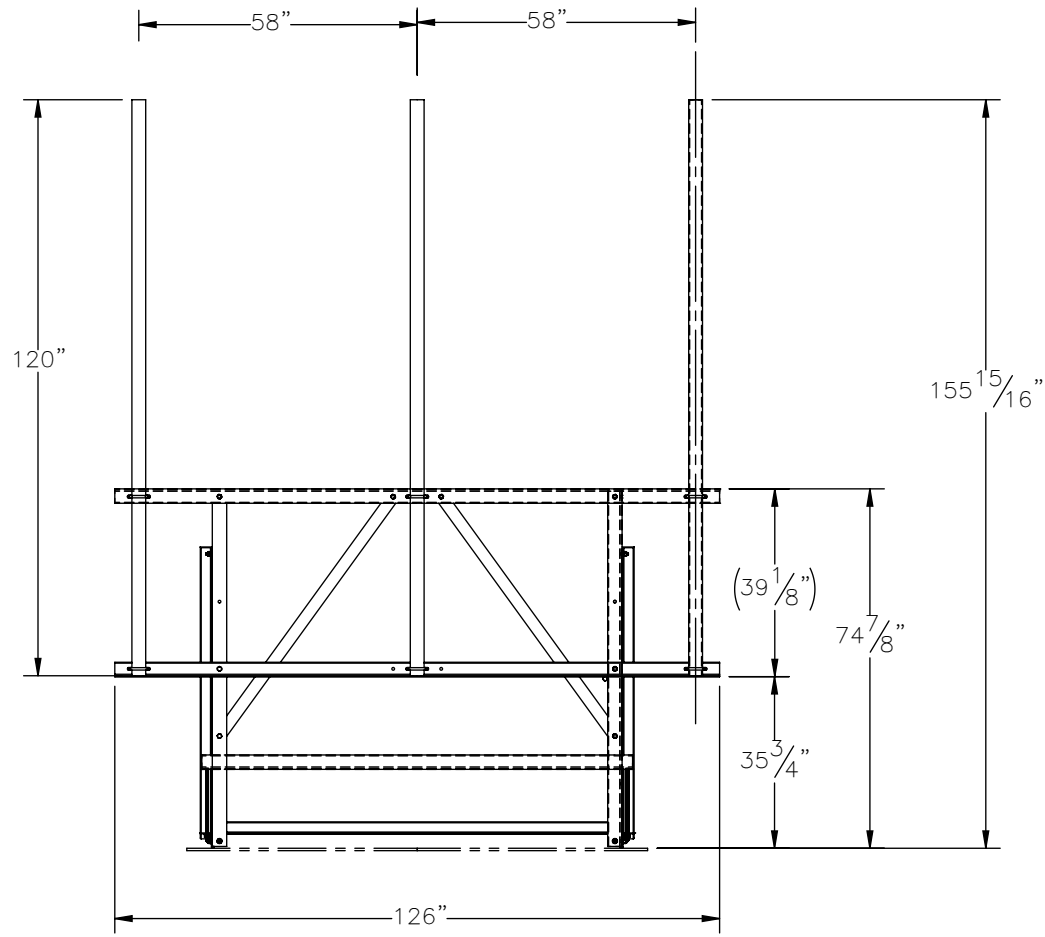
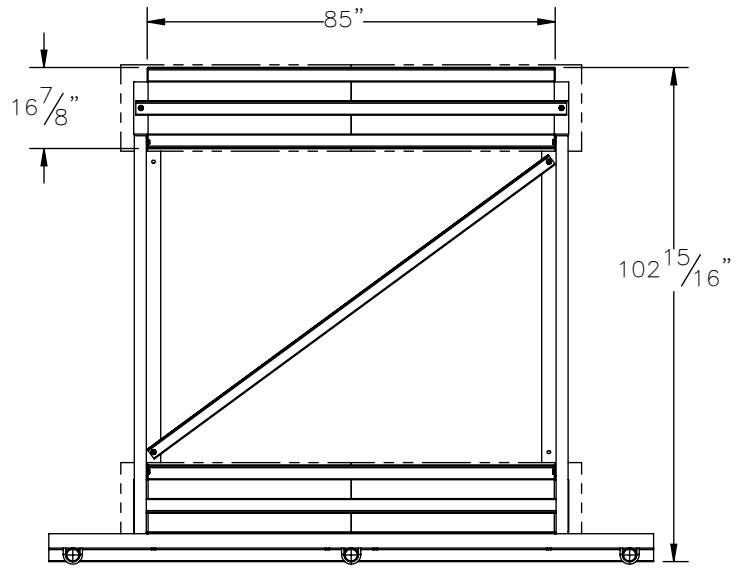

QUOTE DRAWING

SURFACE FINISH <input checked="" type="checkbox"/> UNLESS OTHERWISE SPECIFIED		UNLESS OTHERWISE SPECIFIED DIMENSIONS ARE IN INCHES		APPROVALS	DATE	ELECTRO MECHANICAL INDUSTRIES, INC. 11230 NEESEHAW DRIVE HOUSTON, TEXAS 77065 1-800-453-0050
MATERIAL	SEE PARTS LIST	TOLERANCES		DRAWN	8/18/2021	
THIRD ANGLE PROJECTION		.0 ±.06		CHECKER		TITLE:
		.00 ±.015		ENGINEER		ROOFTOP SLED FRAME, 10 FT FACE, (3) 2.875" O.D. X 120 IN. PIPES
		.000 ±.005		PRODUCTION		SIZE
NEXT ASSY	USED ON	FRACTIONS ± 1/16				B
		ANGLES ± .25°				DRAWING NO.
		HOLES: DRILLED OR PUNCHED ± 1/32				1000-0010-0297 QUOTE
APPLICATIONS		BURNED ± 1/32				REV
						—
						SCALE: 1:40
						WEIGHT: 641.54 lbs.
						SHEET 1 OF 1