

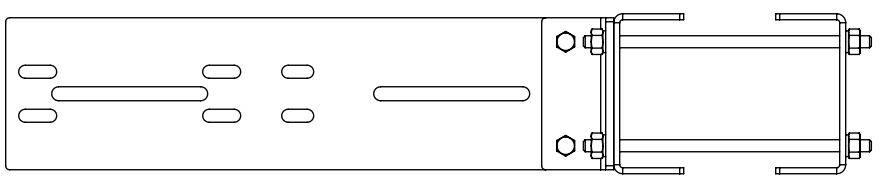

THE INFORMATION CONTAINED IN THIS DRAWING IS THE SOLE PROPERTY OF ELECTRO MECHANICAL INDUSTRIES, INC. ANY REPRODUCTION IN PART OR WHOLE WITHOUT THE WRITTEN PERMISSION OF ELECTRO MECHANICAL IND., IS PROHIBITED.

SALES

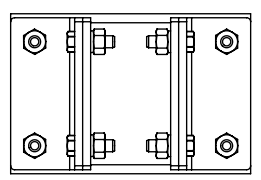
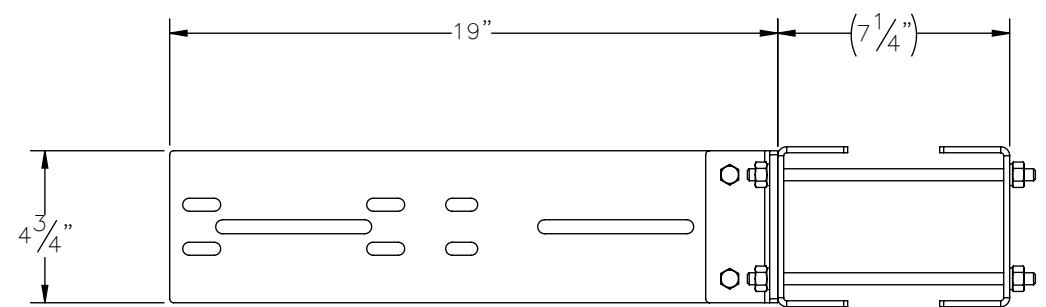
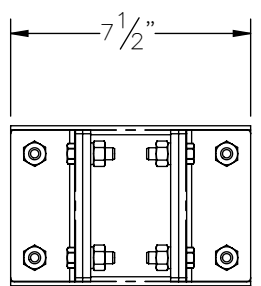
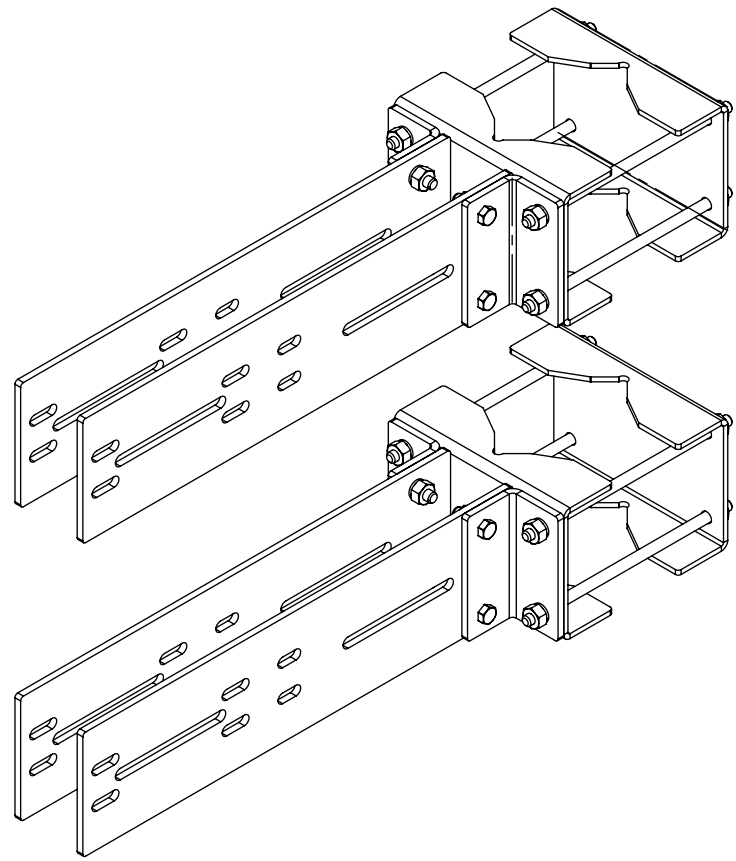
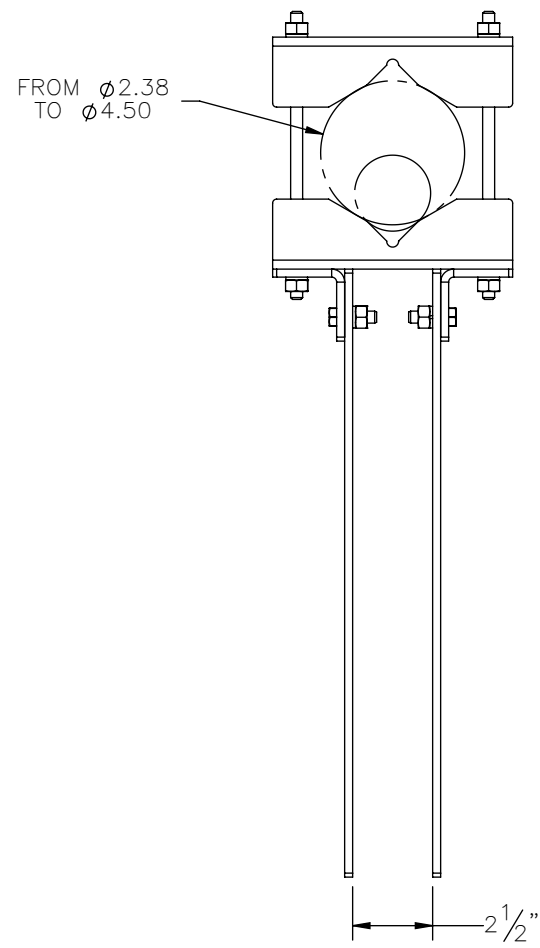
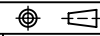

| | | | | | | |
|--|--|---|--|------------------|-----------|---|
| SURFACE FINISH <input checked="" type="checkbox"/> UNLESS OTHERWISE SPECIFIED | | UNLESS OTHERWISE SPECIFIED DIMENSIONS ARE IN INCHES | | APPROVALS | DATE |  ELECTRO MECHANICAL INDUSTRIES, INC. 11230 NEESEHAW DRIVE HOUSTON, TEXAS 77065 1-800-453-0050 |
| MATERIAL SEE PARTS LIST | | TOLERANCES | | DRAWN C. SANCHEZ | 8/23/2021 | |
| THIRD ANGLE PROJECTION  | | .0 $\pm .06$ | | CHECKER | | SIZE B |
| NEXT ASSY USED ON | | .000 $\pm .015$ | | ENGINEER | | DRAWING NO. 1000-0010-0299 |
| APPLICATIONS | | FRACTIONS $\pm \frac{1}{16}$ | | PRODUCTION | | REV 0 |
| | | ANGLES $\pm .25^\circ$ | | | | SCALE: 1:6 |
| | | HOLES: DRILLED OR PUNCHED $\pm \frac{1}{32}$ | | | | WEIGHT: 45.43 lbs. |
| | | BURNED $\pm \frac{1}{32}$ | | | | SHEET 1 OF 1 |