

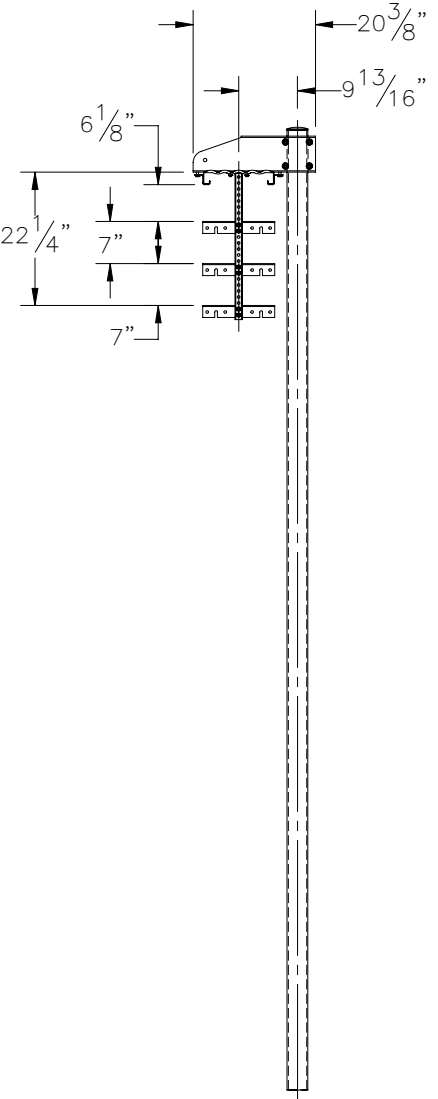

THE INFORMATION CONTAINED IN THIS DRAWING IS THE SOLE PROPERTY OF ELECTRO MECHANICAL INDUSTRIES, INC. ANY REPRODUCTION IN PART OR WHOLE WITHOUT THE WRITTEN PERMISSION OF ELECTRO MECHANICAL IND., IS PROHIBITED.

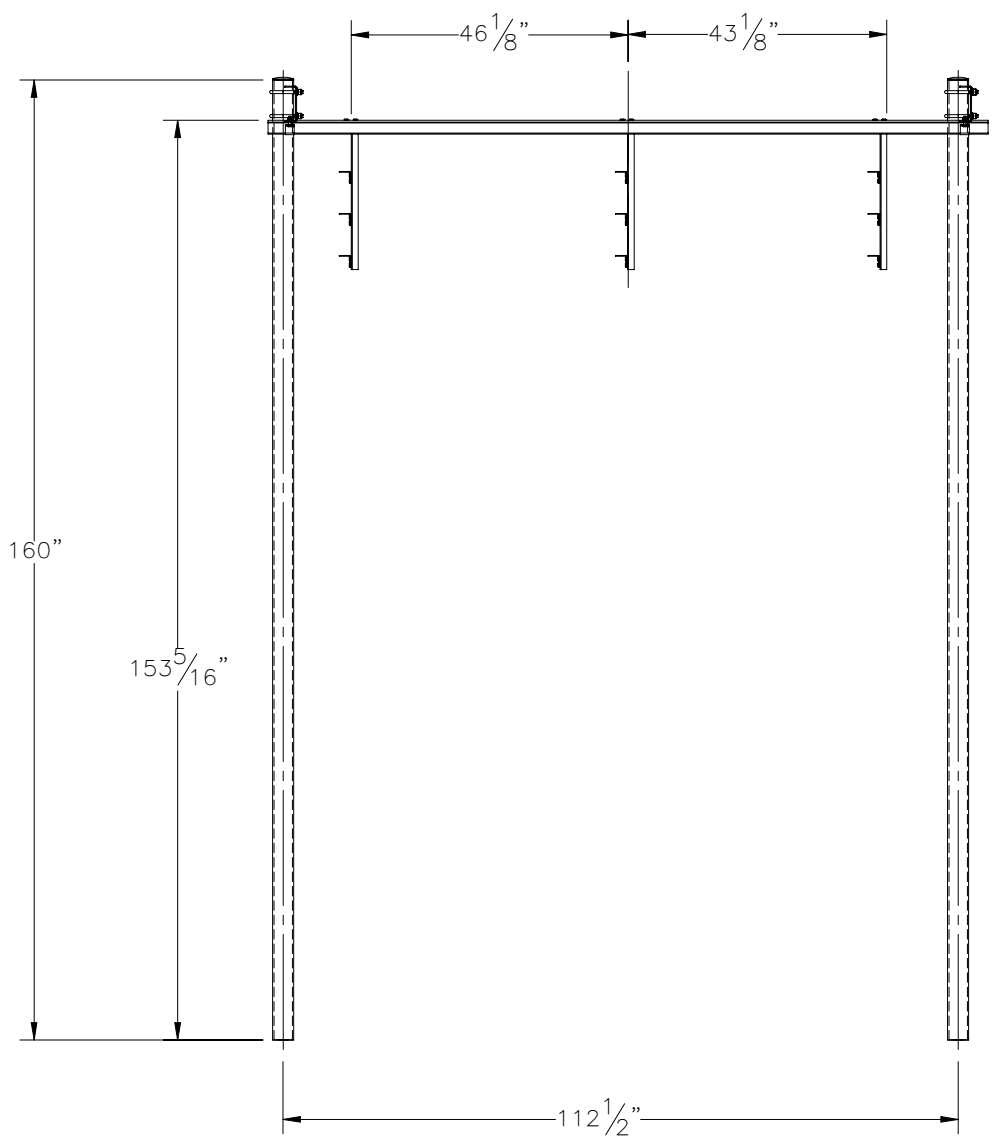
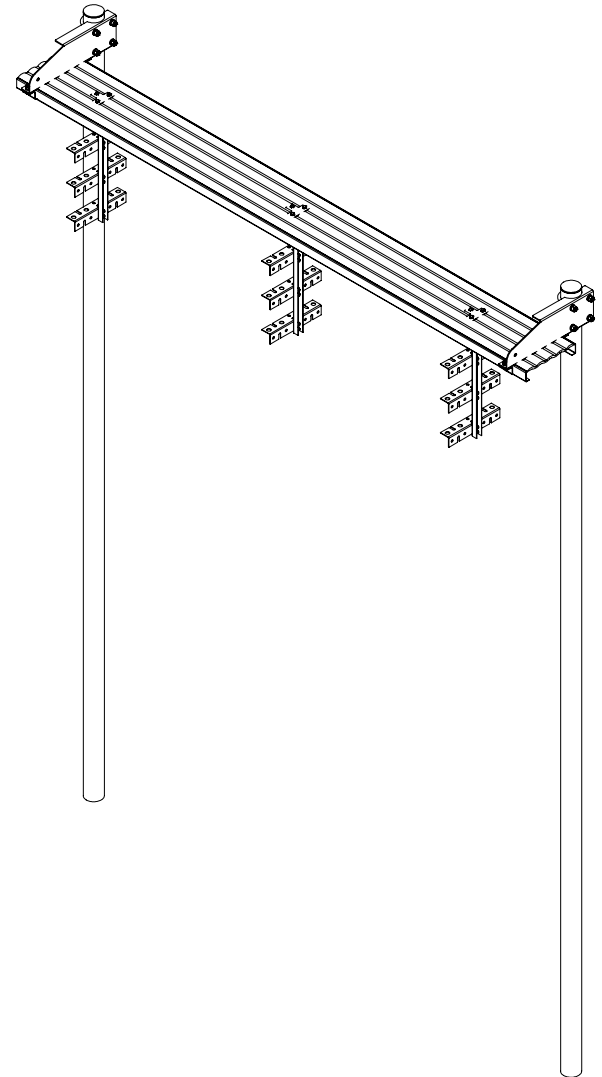
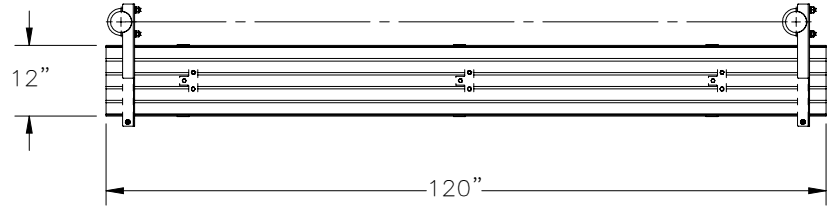

ITEM NO.	QTY REQD	PART NUMBER	DESCRIPTION	LENGTH	WEIGHT
1	2	P-005-071	BRIDGE SUPPORT BRACKET		8.29
2	1	--	GRIP STRUT, 12" X 120" X 2"		
3	4	P-005-072	SUPPORT BRACKET		0.19
4	4	002-00U-G021	U-BOLT, .500-13 X 1.5 THD LG., 3.50 I.D. X 5.0 HT, ASTM A307, GALV.		0.09
5	8	002-0FW-G002	FW, .50, F436, HDG		0.02
6	8	002-0LW-G002	WASHER, SPLIT LOCK, .500", GALV		0.01
7	8	002-0NG-0010	NUT, HEX, .500-13UNC, GR 2H, GALV		0.06
8	4	002-0BG-0008	BOLT, HEX HD, .375-16UNC X 1.5 LG, GR 5, GALV		0.06
9	4	002-0FW-G005	WASHER, FLAT, .375, GALV		0.01
10	4	002-0LW-G005	WASHER, SPLIT LOCK, .375 INCH, GALV.		0.01
11	4	002-0NG-0003	NUT, HEX, .375-16UNC, GR 2H, GALV		0.03
12	3	A-000-517	TRAPEZE KIT - 12" WD, 12 RUN		6.94
13	2	FENCE POST CAP,	FENCE POST CAP, 3 1/2", GALV.		0.17
14	2	PP1-0300-S40M	PIPE, 3.00 INCH, SCH. 40, ASTM A500 GR. B STL., PP1-0300-S40M	160"	101.11

SURFACE FINISH <input checked="" type="checkbox"/> UNLESS OTHERWISE SPECIFIED		UNLESS OTHERWISE SPECIFIED DIMENSIONS ARE IN INCHES		APPROVALS		DATE		 ELECTRO MECHANICAL INDUSTRIES, INC. 11230 NEESESHAW DRIVE HOUSTON, TEXAS 77065 1-800-453-0050	
MATERIAL SEE PARTS LIST		TOLERANCES		DRAWN P. GUTIERREZ		8/19/2021			
THIRD ANGLE PROJECTION 		.0 ± .06 .00 ± .015 .000 ± .005		CHECKER				TITLE: <h3 style="text-align: center;">ICE BRIDGE KIT</h3>	
NEXT ASSY		FRACTIONS ± 1/16 ANGLES ± .25°		ENGINEER					
USED ON		HOLES: DRILLED OR PUNCHED ± 1/32 BURNED ± 1/32		PRODUCTION				SIZE B DRAWING NO. 1000-0010-0300 QUOTE REV -- SCALE: 1:32 WEIGHT: 395.21 lbs. SHEET 1 OF 1	