

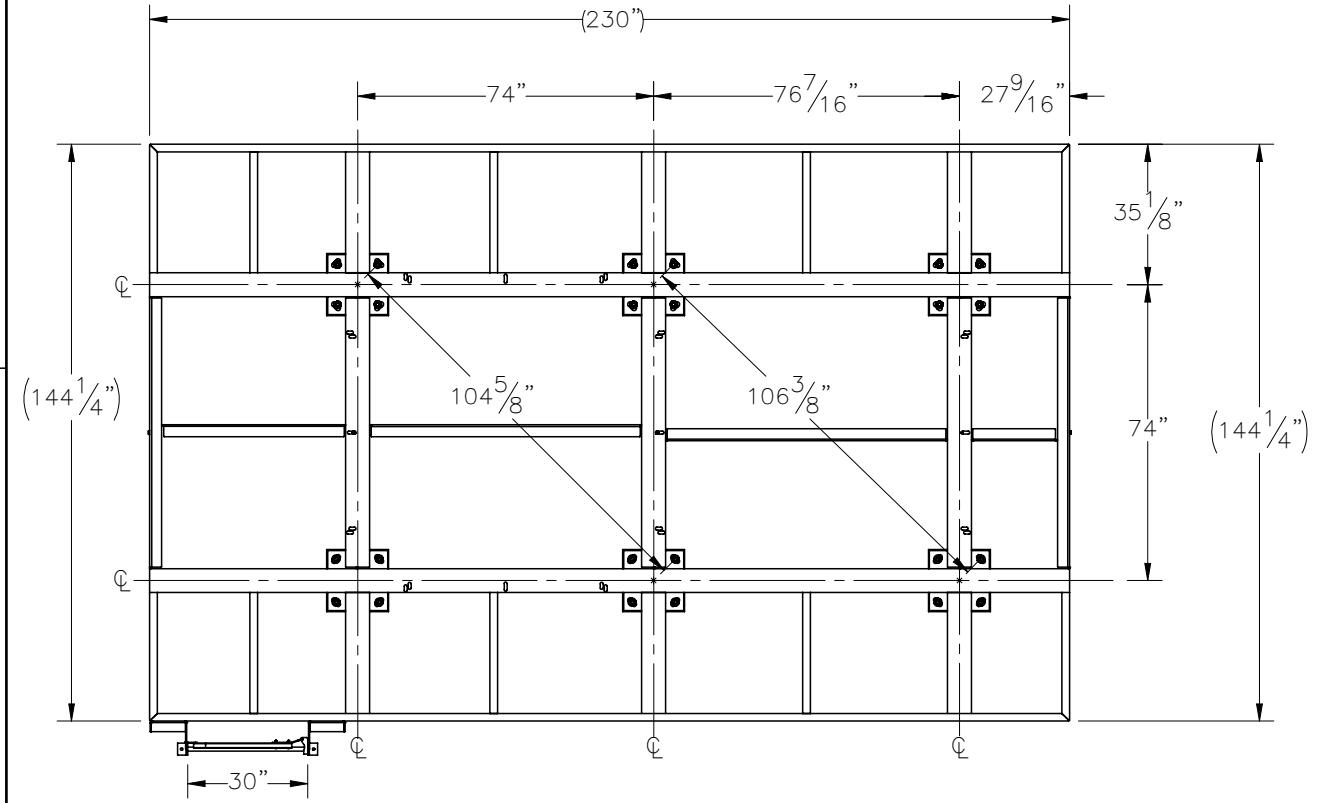

THE INFORMATION CONTAINED IN THIS DRAWING IS THE SOLE PROPERTY OF ELECTRO MECHANICAL INDUSTRIES, INC. ANY REPRODUCTION IN PART OR WHOLE WITHOUT THE WRITTEN PERMISSION OF ELECTRO MECHANICAL IND., IS PROHIBITED.

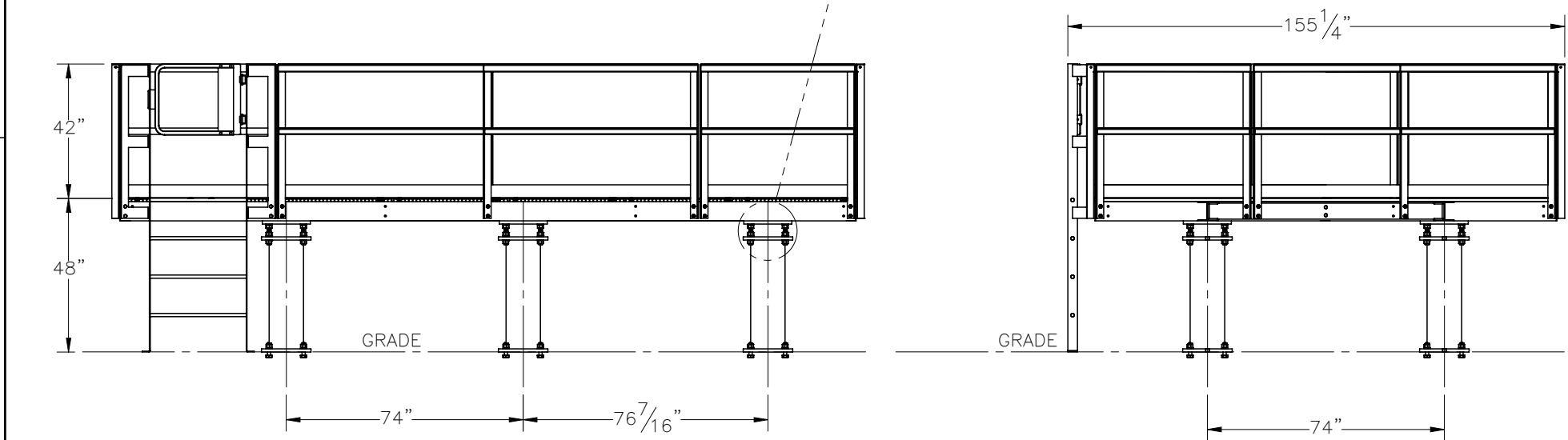

SHOWN WITHOUT GRATING AND HANDRAILS

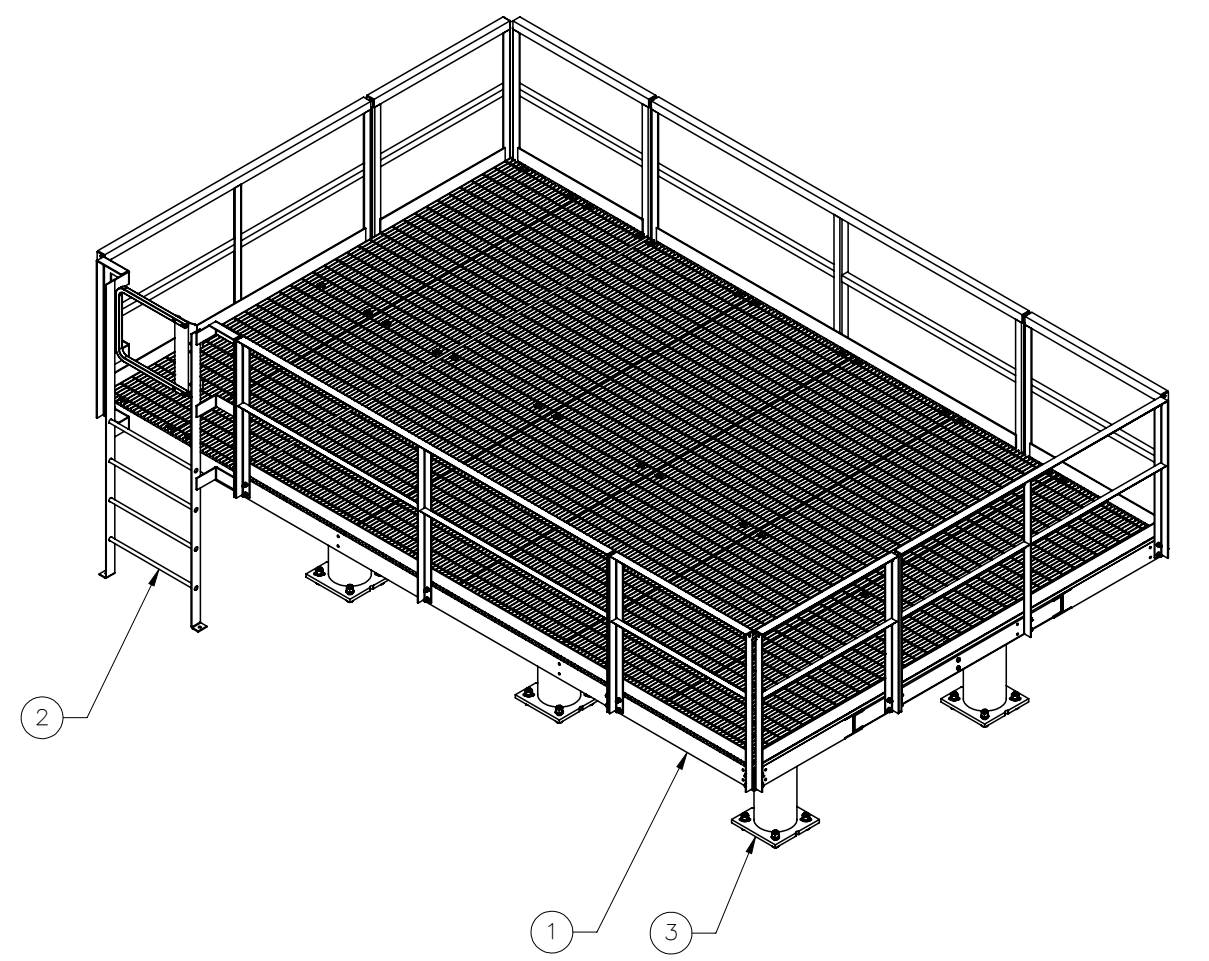
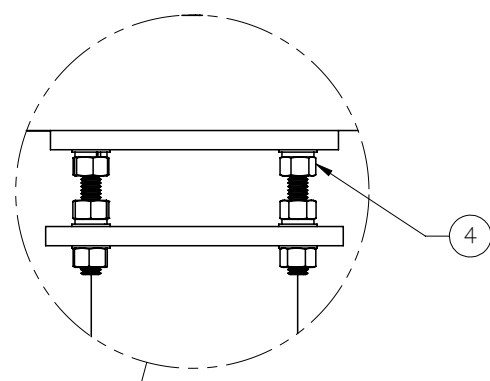

ITEM NO.	QTY REQD	PART NUMBER	DESCRIPTION	LENGTH	WEIGHT
1	1	1001-0020-0138	12' X 19' EQUIPMENT PLATFORM		4902.5
2	1	1005-0420-0480	48" LADDER ASSEMBLY, 42" WIDE		124.6
3	6	1007-T010-0360	3.0 FT EXTENSION		215.7
4	6	1000-0020-0077	QUAD MOUNT 1" LEVELING HARDWARE KIT		15.17

SURFACE FINISH <input checked="" type="checkbox"/> UNLESS OTHERWISE SPECIFIED		UNLESS OTHERWISE SPECIFIED DIMENSIONS ARE IN INCHES		APPROVALS		DATE		 ELECTRO MECHANICAL INDUSTRIES, INC. 11230 NEESHAW DRIVE HOUSTON, TEXAS 77065 1-800-453-0050	
MATERIAL SEE PARTS LIST		TOLERANCES .0 ± .06 .00 ± .015 .000 ± .005		DRAWN F. BAYEH		12/18/2023			
THIRD ANGLE PROJECTION 		FRACTIONS ± 1/16		CHECKER J. Breen		12/18/2023		TITLE: <b>WUC AND GENERATOR PLATFORM, 4' ELEV.</b>	
NEXT ASSY USED ON		ANGLES ± .25°		ENGINEER J. Breen		12/18/2023			
APPLICATIONS		HOLES: DRILLED OR PUNCHED ± 1/32		PRODUCTION J. KERNER		12/18/2023		SIZE B DRAWING NO. 1000-0010-0353-04 REV - SCALE: 1:48 WEIGHT: 6412.57 lbs. SHEET 1 OF 1	