

THE INFORMATION CONTAINED IN THIS DRAWING IS THE SOLE PROPERTY OF ELECTRO MECHANICAL INDUSTRIES, INC. ANY REPRODUCTION IN PART OR WHOLE WITHOUT THE WRITTEN PERMISSION OF ELECTRO MECHANICAL IND., IS PROHIBITED.

REVISIONS					
REV.	DCN #	DESCRIPTION	DATE	BY	APPROVED
2	01213	UPDATED WITH LOWER LEVEL CHANGES.	01/25/2023	JTR	JPB

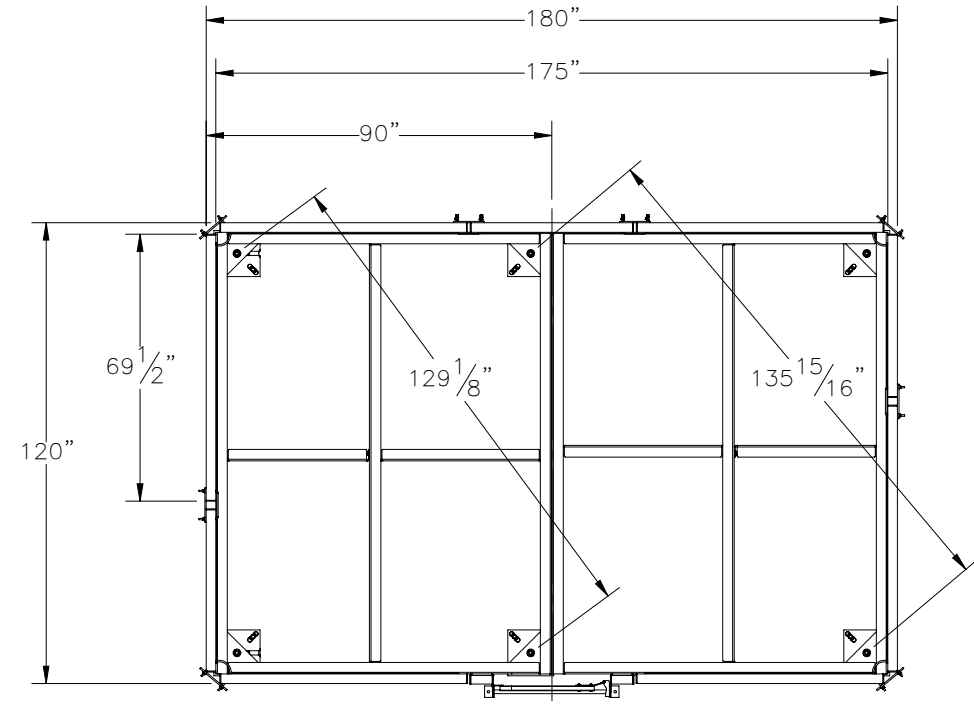

GRATING REMOVED FOR CLARITY

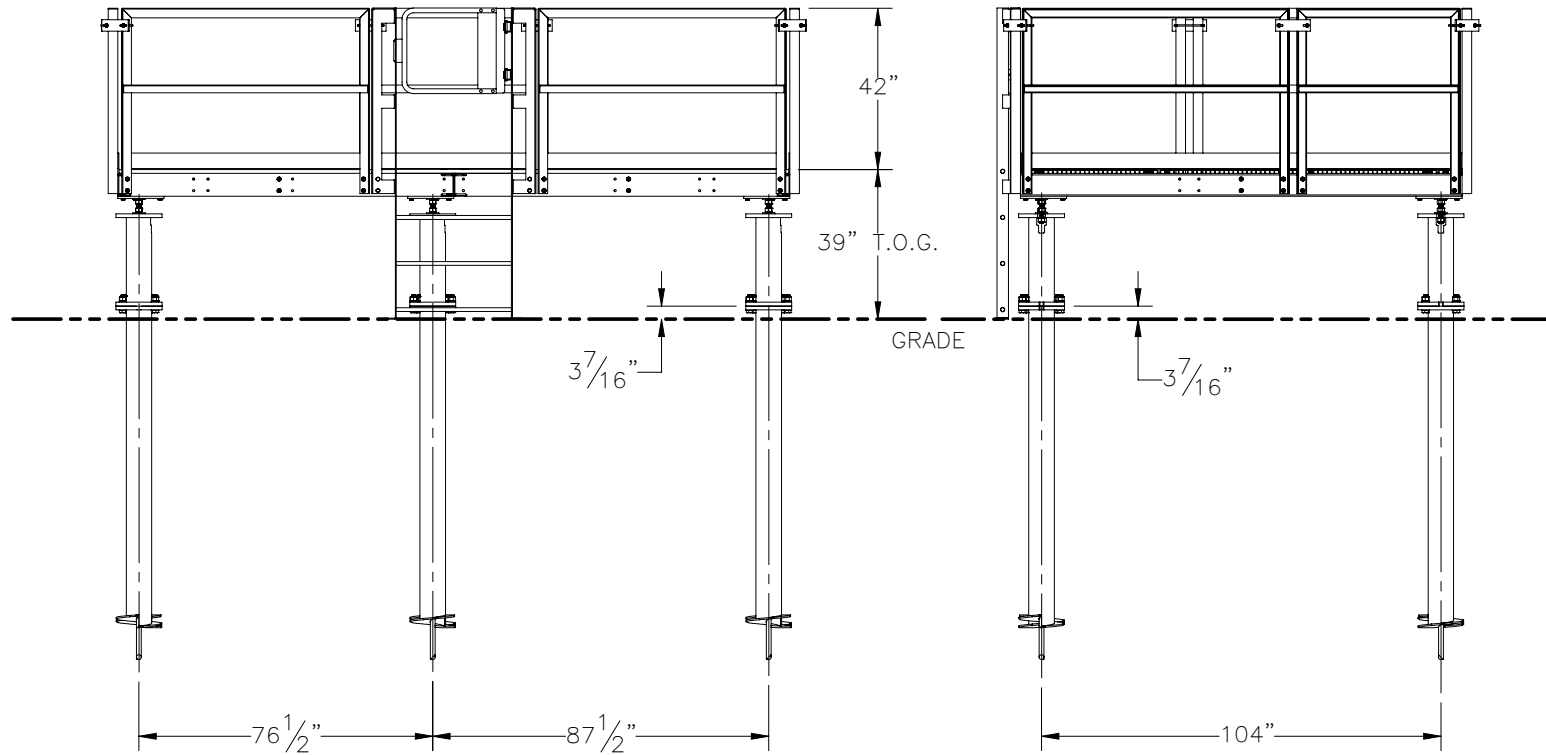
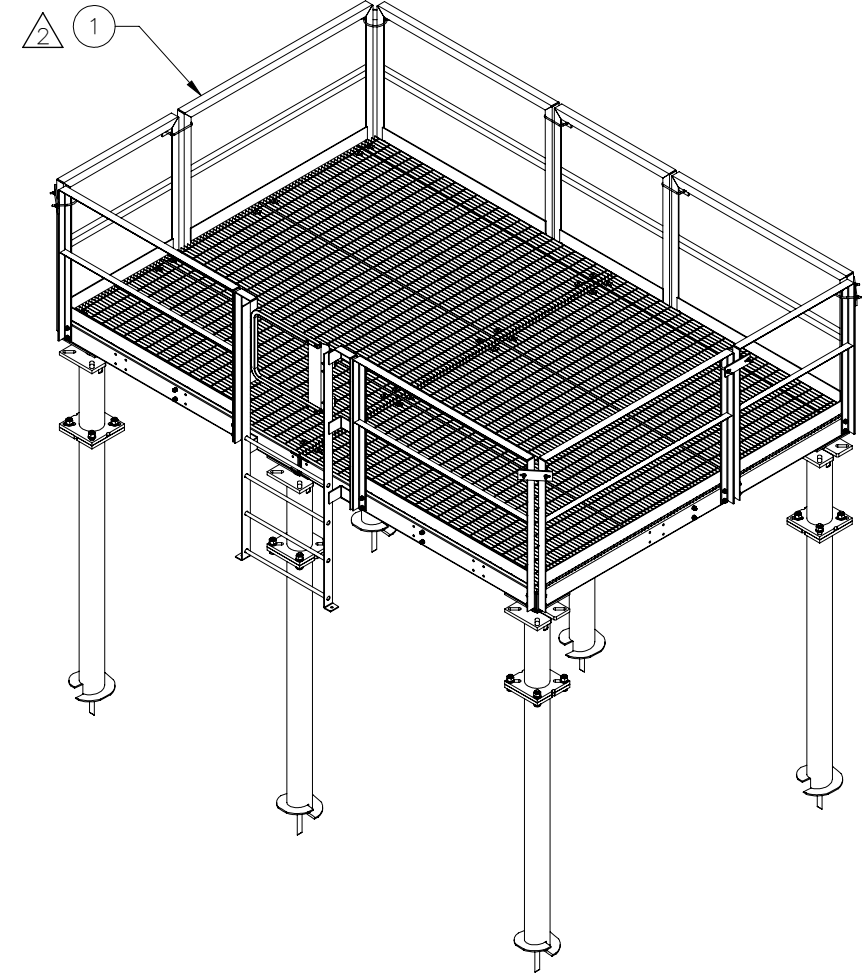

ITEM NO.	QTY REQD	PART NUMBER	DESCRIPTION	LENGTH	WEIGHT
1	1	1000-0010-0405-03	10' X 15' BOLT TOGETHER EQUIP. PLATFORM, LADDER		4602.25

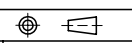
SURFACE FINISH <input checked="" type="checkbox"/> UNLESS OTHERWISE SPECIFIED		UNLESS OTHERWISE SPECIFIED DIMENSIONS ARE IN INCHES		APPROVALS		DATE		 ELECTRO MECHANICAL INDUSTRIES, INC. 11230 NEESESHAW DRIVE HOUSTON, TEXAS 77065 1-800-453-0050	
MATERIAL SEE PARTS LIST		TOLERANCES		DRAWN		10/13/2022			
THIRD ANGLE PROJECTION 		.0 ±.06 .00 ±.015 .000 ±.005		CHECKER		10/13/2022			
NEXT ASSY		FRACTIONS ± 1/16 ANGLES ± .25°		ENGINEER		10/13/2022			
USED ON		HOLES: DRILLED OR PUNCHED ± 1/32		PRODUCTION		10/13/2022		TITLE: 10' X 15' BOLT TOGETHER EQUIP. PLATFORM, LADDER	
APPLICATIONS		BURNED ± 1/32		J. KERNER				SIZE B	
								DRAWING NO. 1000-0010-0368	
								REV 2	
								SCALE: 1:50	
								WEIGHT: 4602.25 lbs.	
								SHEET 1 OF 1	