

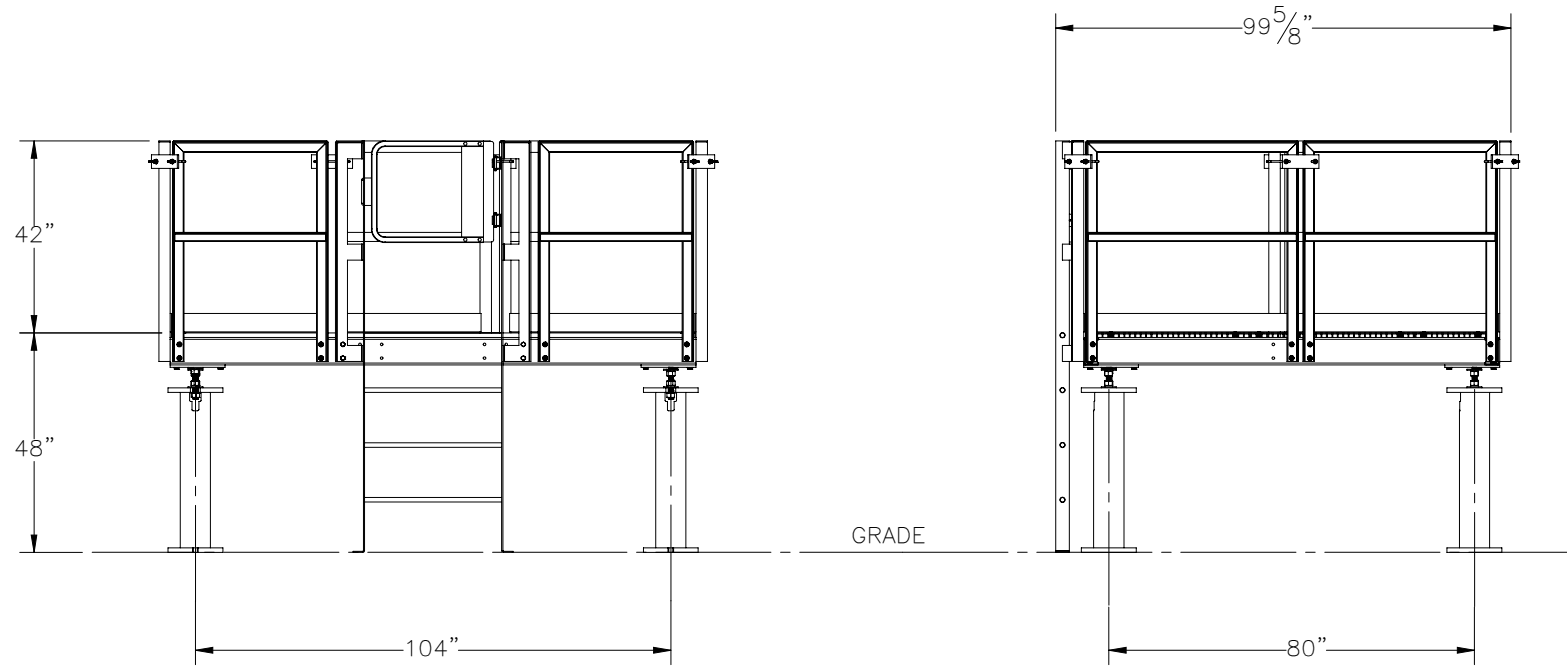

THE INFORMATION CONTAINED IN THIS DRAWING IS THE SOLE PROPERTY OF ELECTRO MECHANICAL INDUSTRIES, INC. ANY REPRODUCTION IN PART OR WHOLE WITHOUT THE WRITTEN PERMISSION OF ELECTRO MECHANICAL IND., IS PROHIBITED.

REVISIONS					
REV.	DCN #	DESCRIPTION	DATE	BY	APPROVED
2	01213	UPDATED WITH LOWER LEVEL CHANGES.	01/25/2023	JTR	JPB

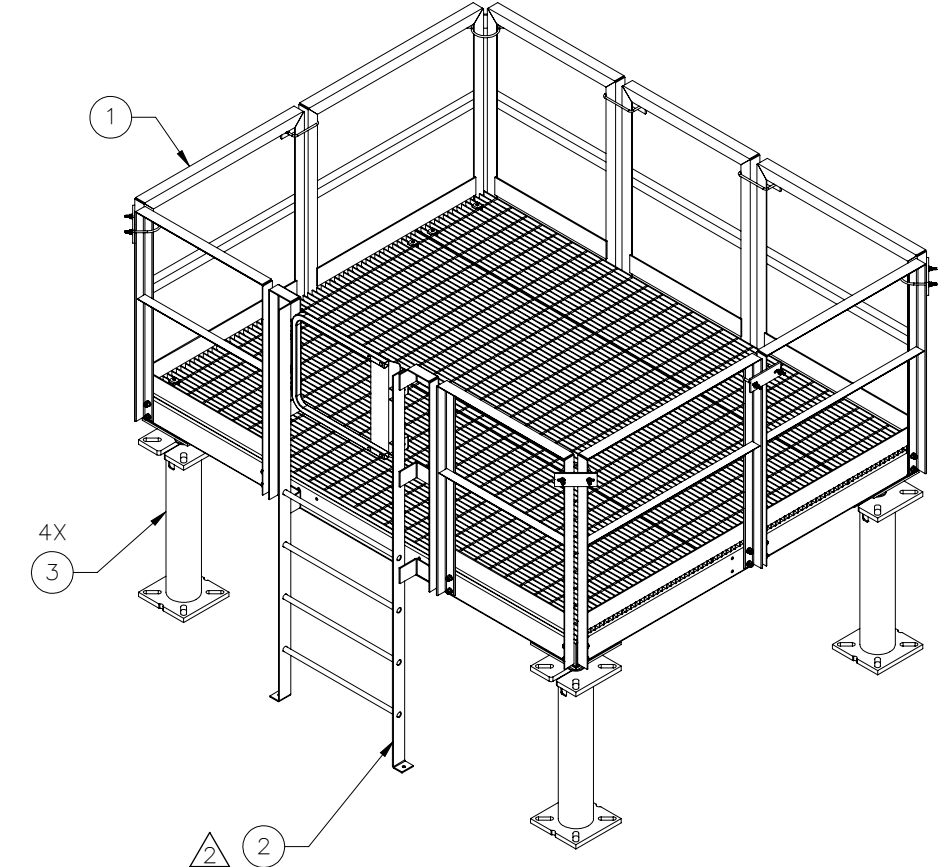
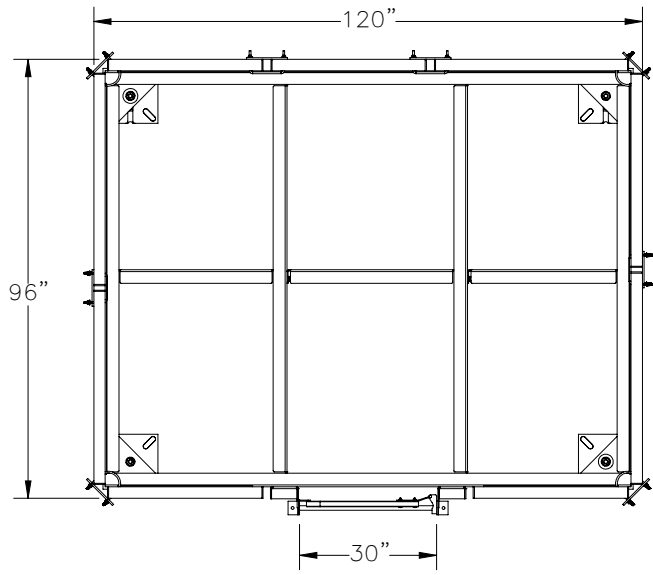

ITEM NO.	PART NUMBER	DESCRIPTION	LENGTH	WEIGHT
1	1001-0020-0134	8' X 10' EQUIPMENT PLATFORM		1731.32
2	1005-0360-0480	48" LADDER ASSEMBLY, 36" WIDE		115.4
3	1008-0030-0007	6" X 36" SINGLE BOLT CONCRETE EXTENSION W/HARDWARE		122.68

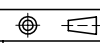
SURFACE FINISH <input checked="" type="checkbox"/> UNLESS OTHERWISE SPECIFIED		UNLESS OTHERWISE SPECIFIED DIMENSIONS ARE IN INCHES		APPROVALS		DATE		 ELECTRO MECHANICAL INDUSTRIES, INC. 11230 NEESEHAW DRIVE HOUSTON, TEXAS 77065 1-800-453-0050	
MATERIAL SEE PARTS LIST		TOLERANCES .0 ± .06 .00 ± .015 .000 ± .005 FRACTIONS ± 1/16 ANGLES ± .25° HOLES: DRILLED OR PUNCHED ± 1/32 BURNED ± 1/32		DRAWN B. HUTSON		10/28/2022			
THIRD ANGLE PROJECTION 				CHECKER J. ROACH		10/28/2022		SIZE B	
NEXT ASSY		USED ON		ENGINEER J. Breen		10/31/2022		DRAWING NO. 1000-0010-0385-04	
APPLICATIONS				PRODUCTION J. KERNER		10/31/2022		REV 2	
								SCALE: 1:42	
								WEIGHT: 2,337.50 lbs.	
								SHEET 1 OF 1	