

THE INFORMATION CONTAINED IN THIS DRAWING IS THE SOLE PROPERTY OF ELECTRO MECHANICAL INDUSTRIES, INC. ANY REPRODUCTION IN PART OR WHOLE WITHOUT THE WRITTEN PERMISSION OF ELECTRO MECHANICAL IND., IS PROHIBITED.

REVISIONS					
REV.	DCN #	DESCRIPTION	DATE	BY	APPROVED
1	01259	ADDED 1008-0050-0051, 002-0BG-0283, 002-0FW-G009, 002-0LW-G008, 002-0NG-0008, UPDATED WITH LOWER LEVEL CHANGES.	08/31/2023	JTR	JPB

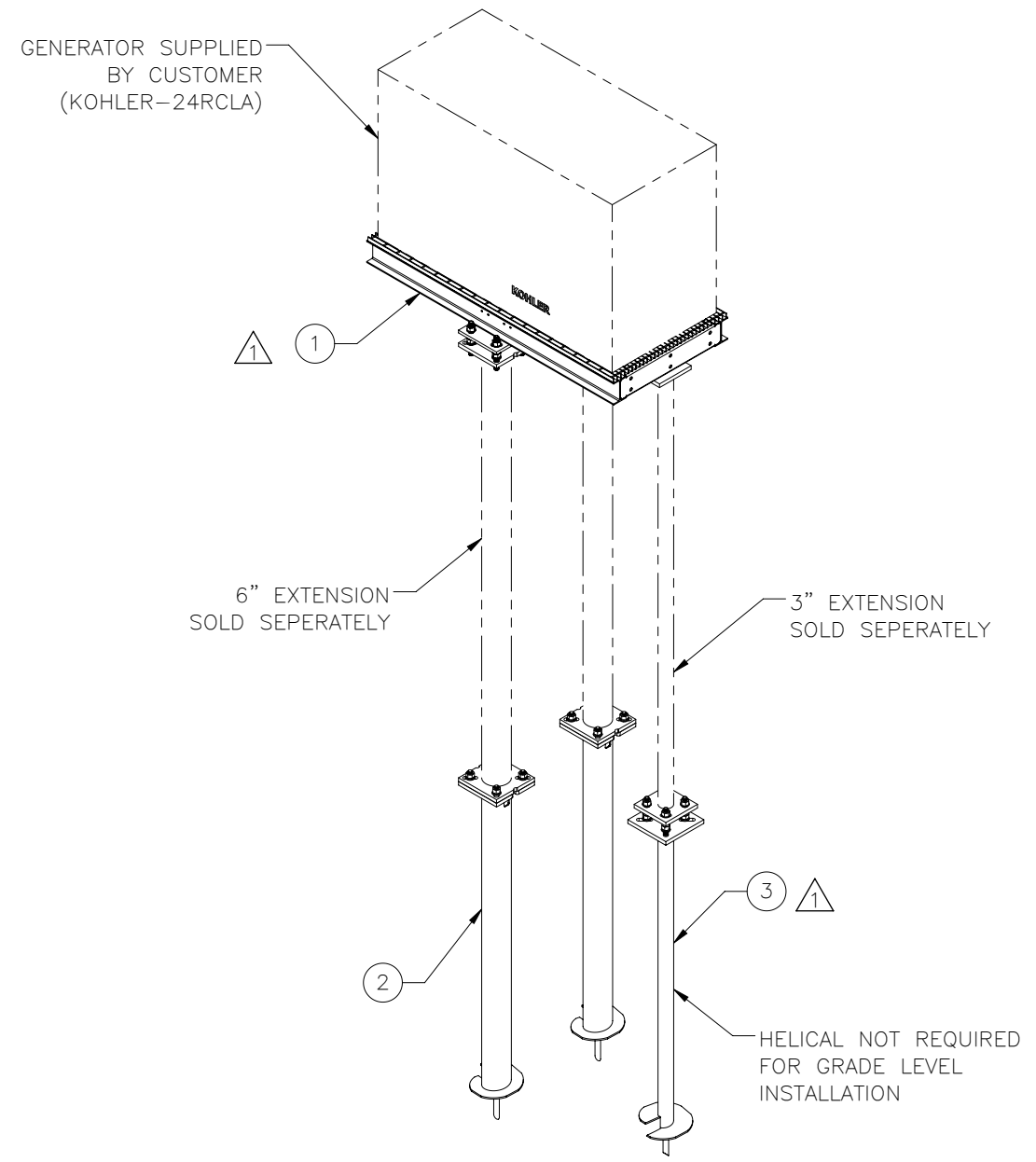
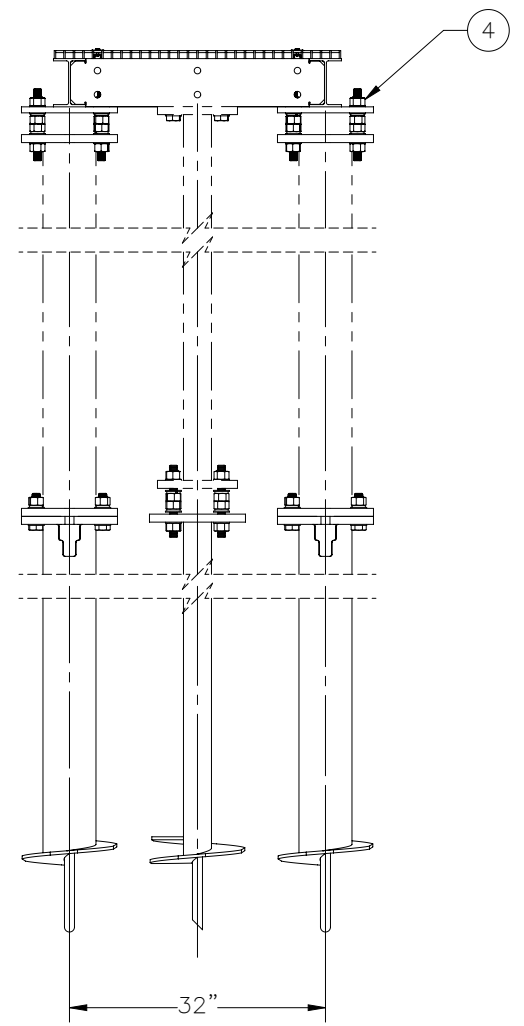
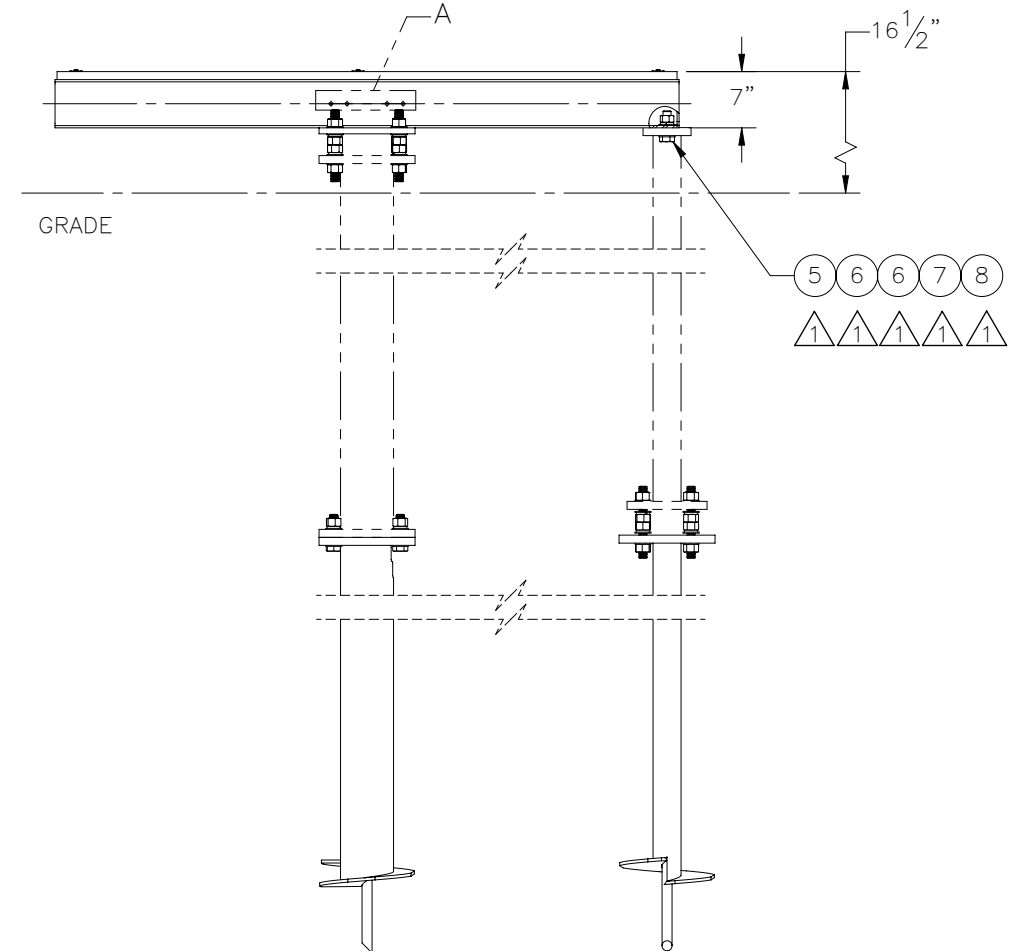
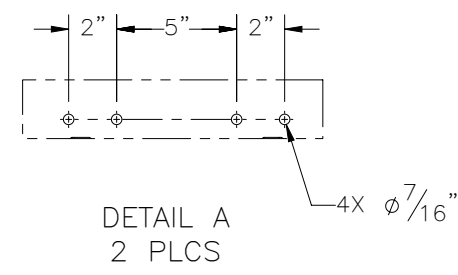
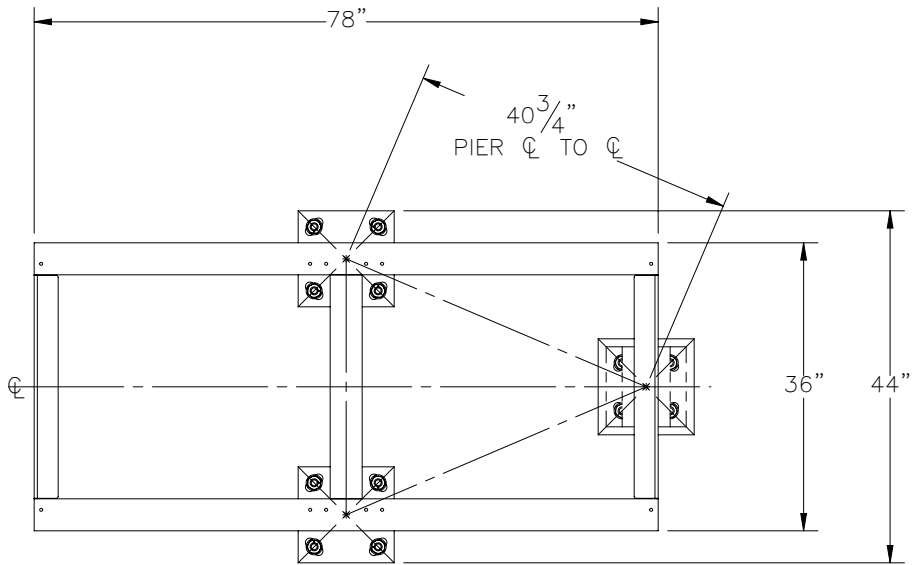

ITEM NO.	QTY REQD	PART NUMBER	DESCRIPTION	LENGTH	WEIGHT
1	1	1001-0020-0149	3' X 6.5' GENERATOR PLATFORM		426.24
2	2	1008-0050-0015	6" X 7', HELICAL, SINGLE STUD OPTION		177.2
3	1	1008-0050-0051	3" X 7' HELICAL, 1" BASE, NO HDW		102.5
4	2	1000-0020-0077	QUAD MOUNT 1" LEVELING HARDWARE KIT		15.17
5	2	002-0BG-0283	BOLT, HH, 1.00-8 X 3.25, GALV, A325, PT X 1.75	3 1/4"	1.1170
6	4	002-0FW-G009	WASHER, FLAT, 1.00, GALV, F436		0.10
7	2	002-0LW-G008	WASHER, SPLIT LOCK, 1.00, GALV		0.09
8	2	002-0NG-0008	NUT, HEX, 1.00-8, GALV, GR 2H		0.282

SURFACE FINISH <input checked="" type="checkbox"/> UNLESS OTHERWISE SPECIFIED		UNLESS OTHERWISE SPECIFIED DIMENSIONS ARE IN INCHES		APPROVALS		DATE			
MATERIAL SEE PARTS LIST		TOLERANCES .0 ±.06 .00 ±.015 .000 ±.005		DRAWN J. ROACH		7/18/2023		TITLE: 3' X 6.5' GENERATOR PLATFORM	
THIRD ANGLE PROJECTION		FRACTIONS ± 1/16 ANGLES ± .25°		CHECKER B. HUTSON		7/19/2023			
NEXT ASSY		DRILLED OR PUNCHED		ENGINEER J. Breen		7/20/2023		SIZE B DRAWING NO. 1000-0010-0454 REV 1	
APPLICATIONS		BURNED ±.002		PRODUCTION J. KERNER		7/20/2023		SCALE: 1:24 WEIGHT: 917 lbs. SHEET 1 OF 1	