

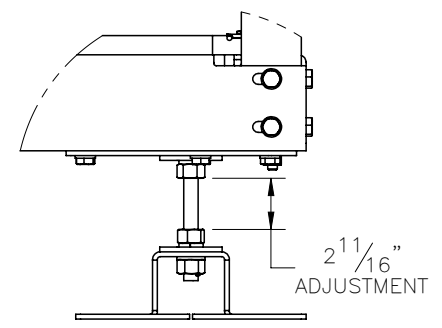

THE INFORMATION CONTAINED IN THIS DRAWING IS THE SOLE PROPERTY OF ELECTRO MECHANICAL INDUSTRIES, INC. ANY REPRODUCTION IN PART OR WHOLE WITHOUT THE WRITTEN PERMISSION OF ELECTRO MECHANICAL IND., IS PROHIBITED.

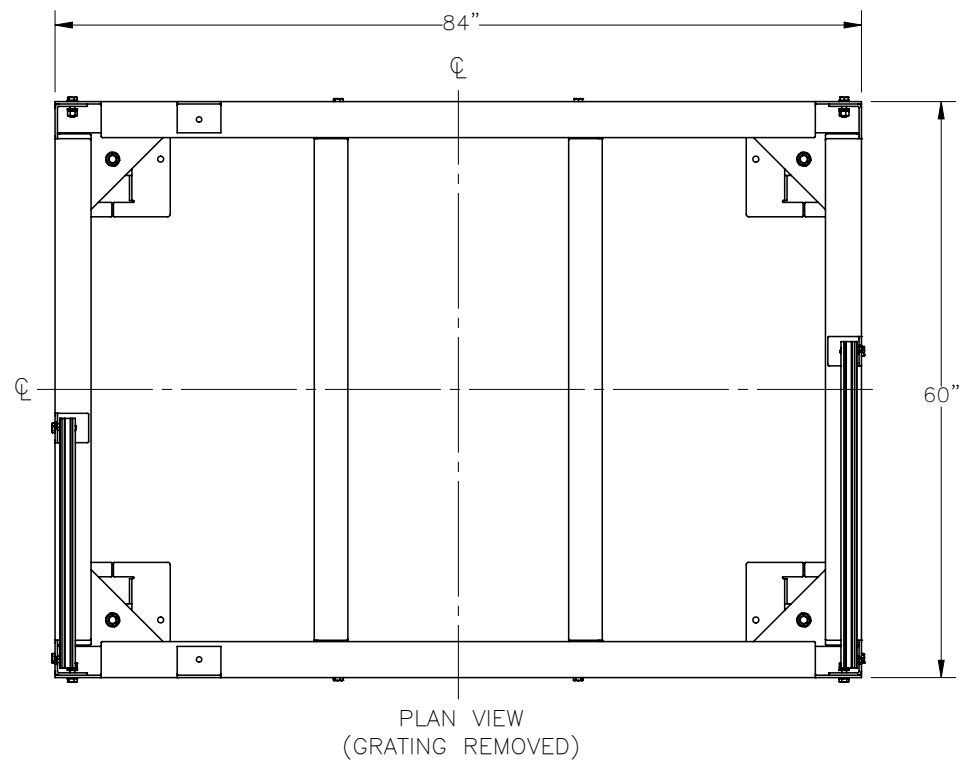

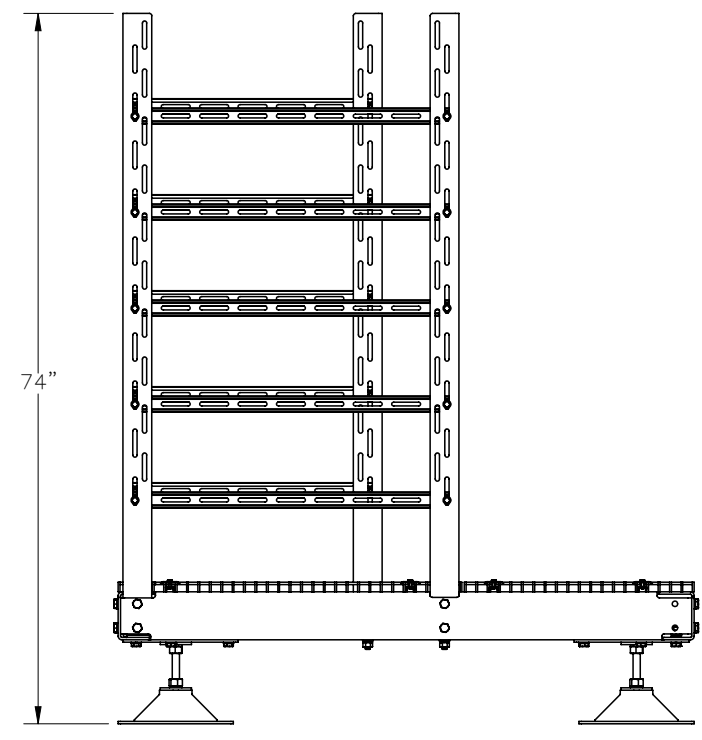
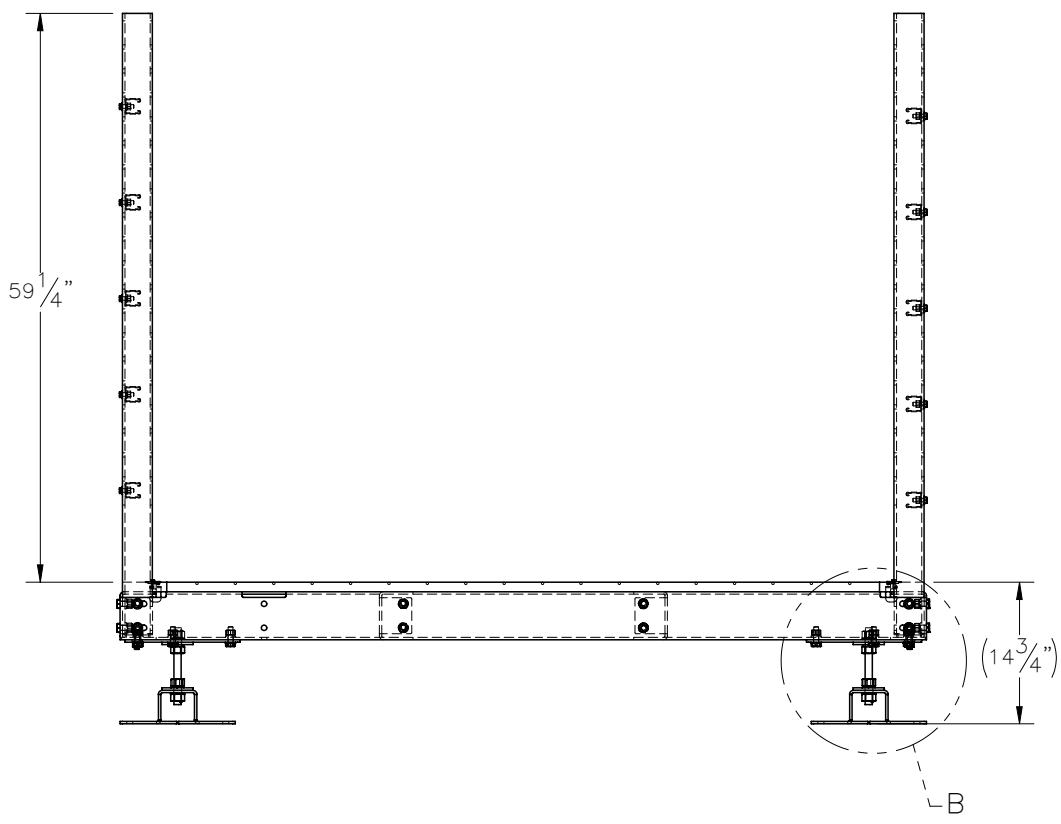
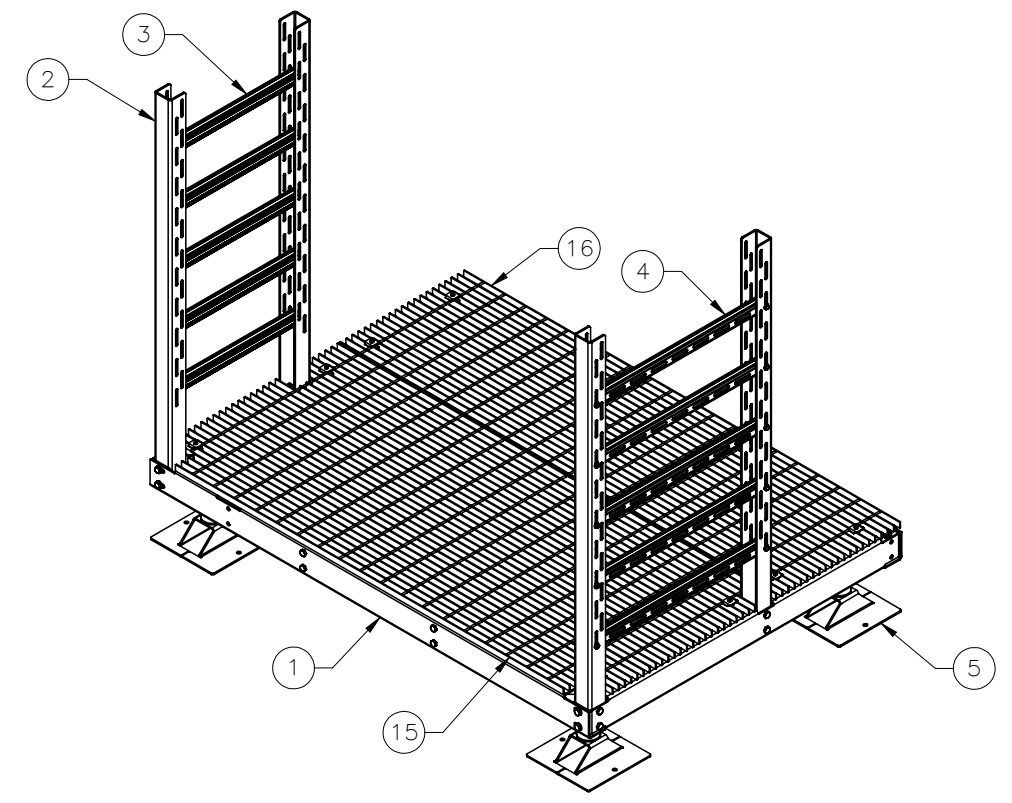

PLATFORM FOOT
LEVELING HARDWARE
DETAIL B

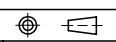

ITEM NO.	QTY. REQD.	PART NUMBER	DESCRIPTION	LENGTH	WEIGHT
1	1	1001-0020-0095	5' X 7' BOLT TOGETHER PLATFORM, FORMED STEEL		343.6
2	4	P-005-973	H-FRAME FORMED COLUMN	65"	35.3
3	5	P-005-974	CROSSBAR, H-FRAME	26"	3.0
4	5	P-005-975	CROSSBAR, H-FRAME	34"	3.9
5	4	P-004-724	PLATFORM FOOT, FORMED		11.1
6	4	1000-0020-0132	SINGLE MOUNT LEVELING HARDWARE KIT, .75" x 8" WITH OVERSIZED WASHER		3.0
7	10	002-0BG-0010	BOLT, HH, .500-13 X 1.50, GALV, A325, PT X 1.00	1 1/2"	0.14
8	10	002-0FW-G002	WASHER, FLAT, .500, GALV, F436		0.03
9	10	002-0LW-G002	WASHER, SPLIT LOCK, .500", GALV		0.01
10	10	002-0NG-0010	NUT, HEX, .500-13, GALV, GR 2H		0.06
11	20	002-0BG-0013	BOLT, HH, .375-16 X 1.25, GALV, GR 5, FT	1 1/4"	0.0571
12	40	002-0FW-G036	WASHER, FLAT, .375, GALV, SAE		0.01
13	20	002-0LW-G005	WASHER, SPLIT LOCK, .375, GALV		0.01
14	20	002-0NG-0003	NUT, HEX, .375-16, GALV, GR 2H		0.030
15	1	P-005-986	GRATING PANEL	83 1/2"	141.9
16	1	T010-0240-0834	GRATING PANEL, 1" THK, SMOOTH, 21 BAR, 23.9375 WIDTH	83 1/2"	98.2
17	8	000-MSG-0008	GRATING CLIP, 1", GALV.		0.20

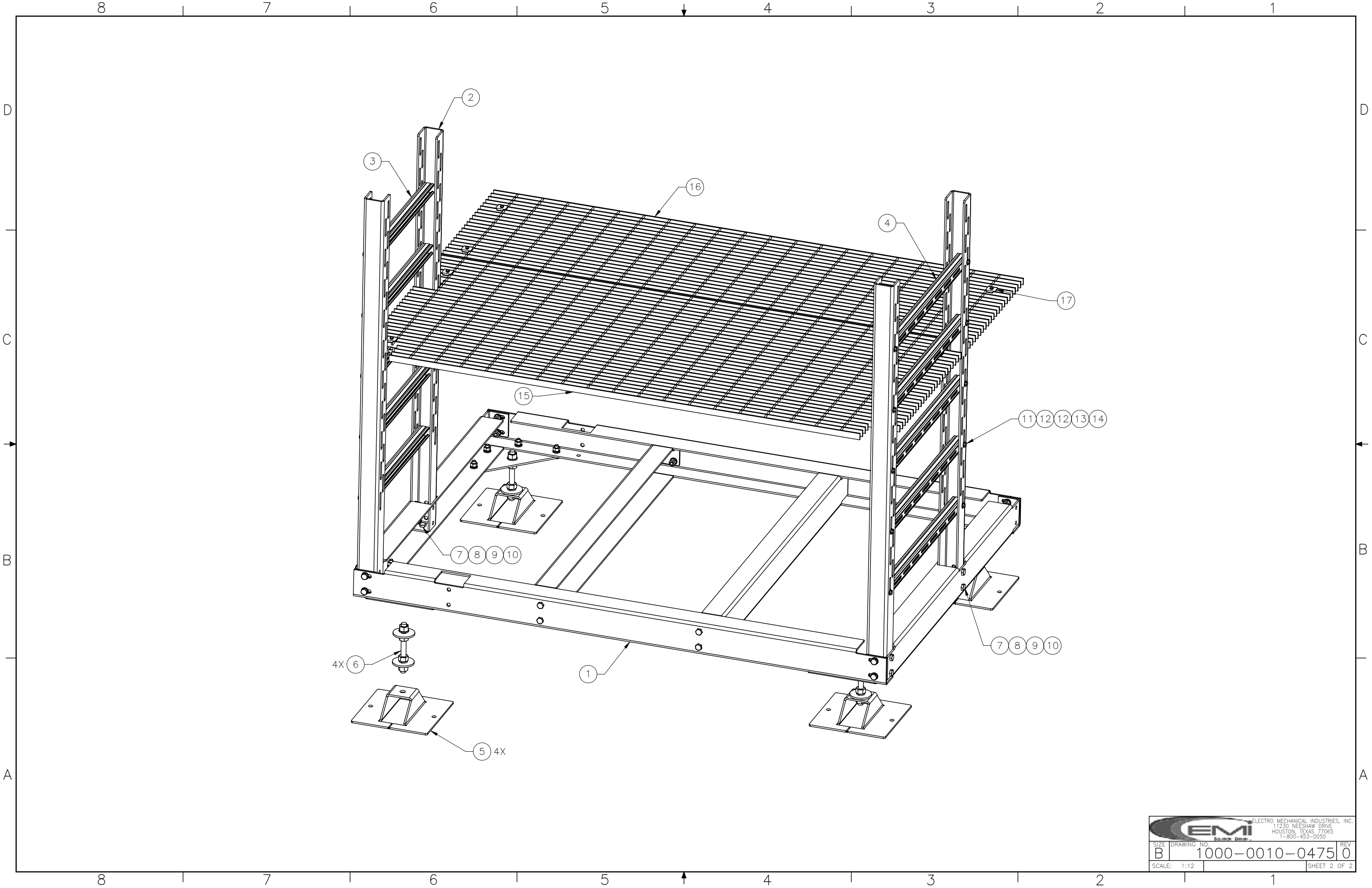
SURFACE FINISH <input checked="" type="checkbox"/> UNLESS OTHERWISE SPECIFIED		UNLESS OTHERWISE SPECIFIED DIMENSIONS ARE IN INCHES		APPROVALS		DATE		 ELECTRO MECHANICAL INDUSTRIES, INC. 11230 NEESEHAW DRIVE HOUSTON, TEXAS 77065 1-800-453-0050	
MATERIAL GALVANIZED STEEL		TOLERANCES .00 ±.06 .000 ±.015 FRACTIONS ± 1/16 ANGLES ±.25°		DRAWN B. HUTSON		7/17/2023			
THIRD ANGLE PROJECTION 		HOLES: DRILLED OR PUNCHED ±1/32		CHECKER J. Breen		7/17/2023		SIZE B	
NEXT ASSY USED ON		BURNED ±1/32		ENGINEER J. Breen		7/17/2023		DRAWING NO. 1000-0010-0475	
APPLICATIONS				PRODUCTION J. KERNER		7/17/2023		REV 0	
								SCALE: 1:20 WEIGHT: 822.5 lbs. SHEET 1 OF 2	



		ELECTRO MECHANICAL INDUSTRIES, INC. 11230 NEESHAW DRIVE HOUSTON, TEXAS 77065 1-800-453-0050	
SIZE	DRAWING NO.	REV.	
B	1000-0010-0475	0	
SCALE: 1:12			SHEET 2 OF 2