

THE INFORMATION CONTAINED IN THIS DRAWING IS THE SOLE PROPERTY OF ELECTRO MECHANICAL INDUSTRIES, INC. ANY REPRODUCTION IN PART OR WHOLE WITHOUT THE WRITTEN PERMISSION OF ELECTRO MECHANICAL IND., IS PROHIBITED.

REVISIONS					
REV.	DCN #	DESCRIPTION	DATE	BY	APPROVED
4	DCN0061B	SWITCHED OUT ZINC HARDWARE FOR GALV. AND TACK WELDED NUTS TO PIPE	02.20.2019	RLWjr	JPB

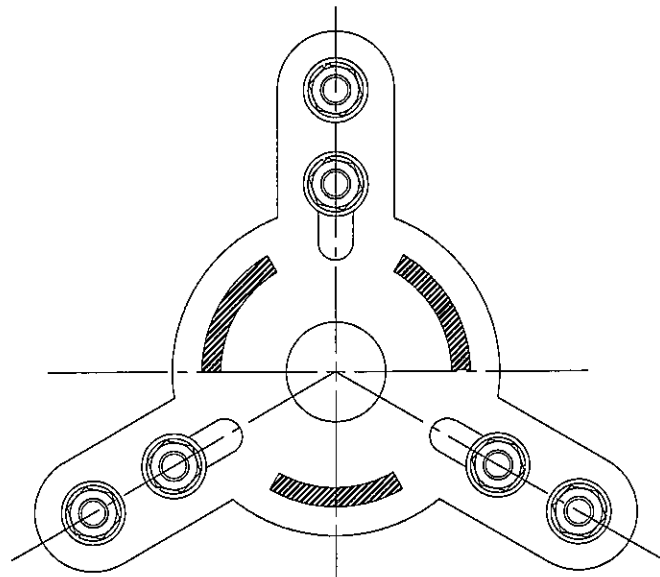

SECTION B-B

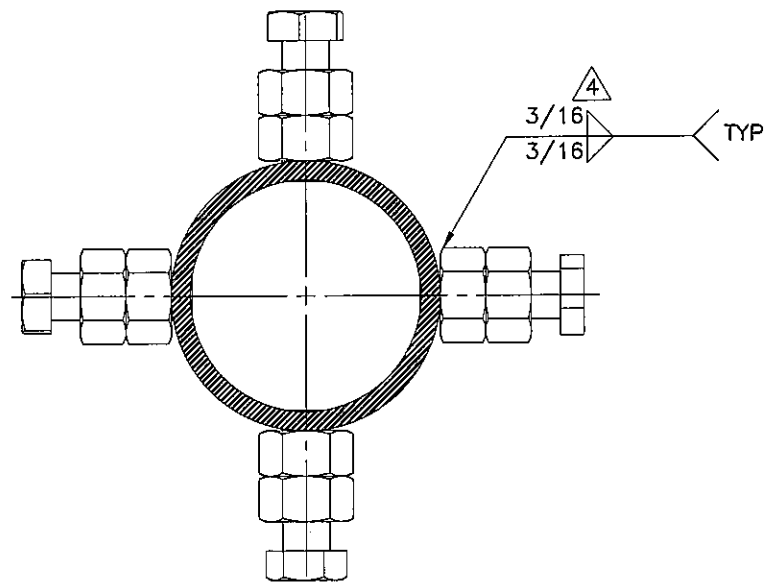

SECTION A-A

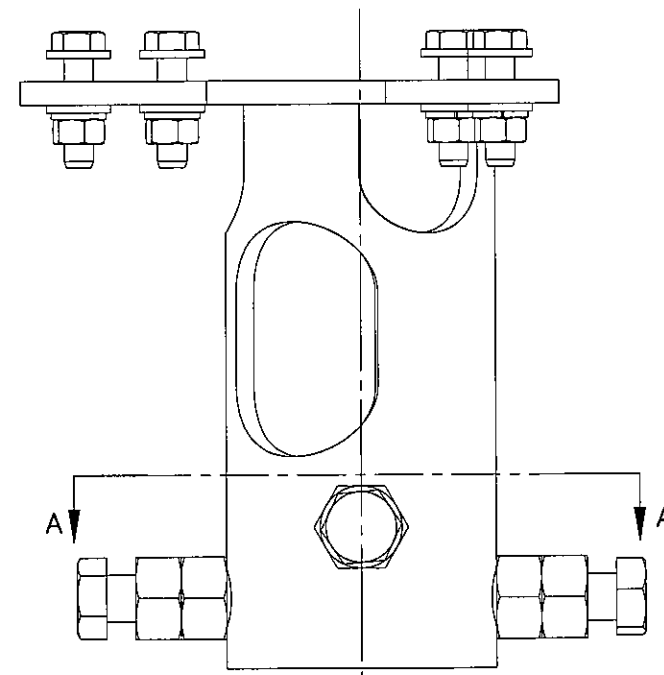
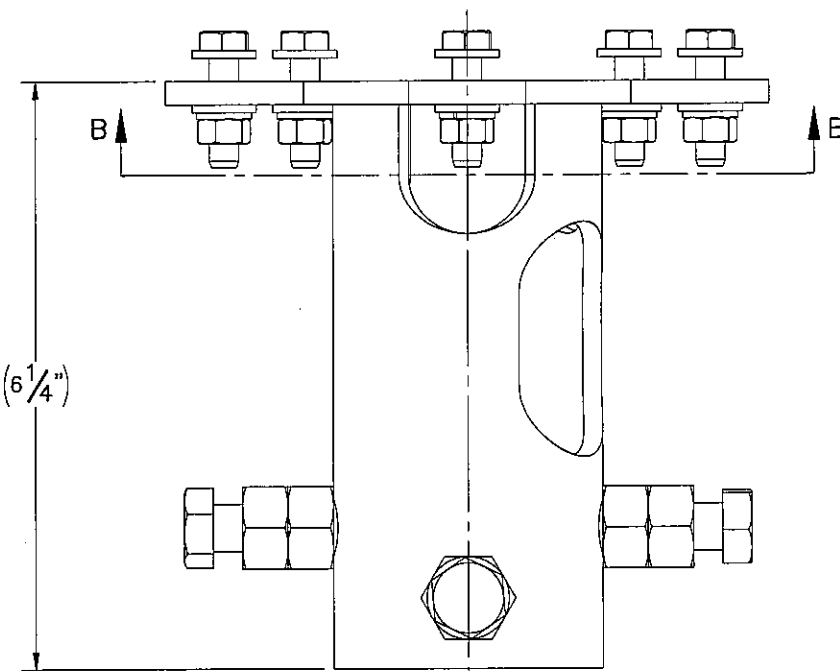
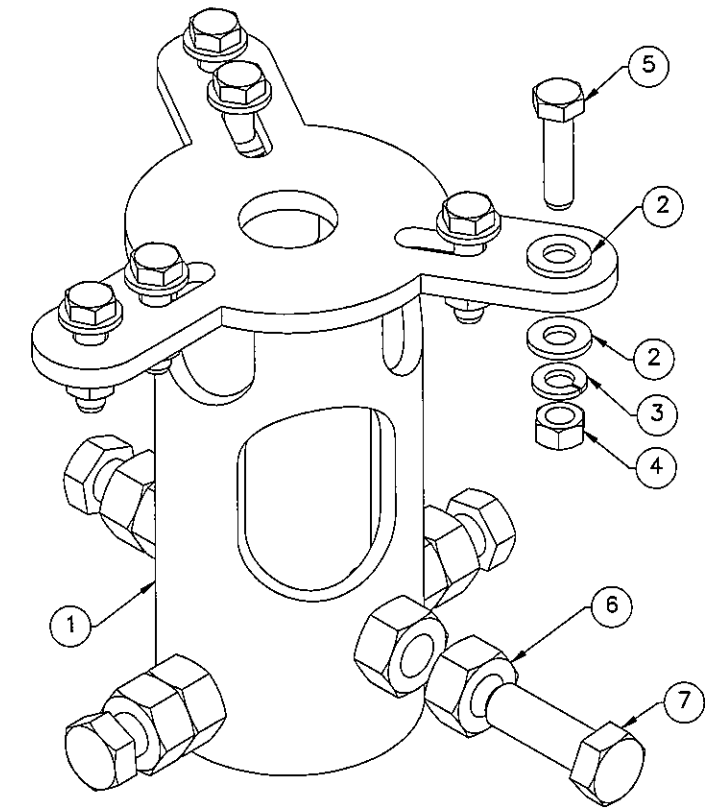

ITEM NO.	QTY REQD	PART NUMBER	DESCRIPTION	WEIGHT
1	1	W-001-064	CANTENNA MOUNT BRACKET	3.30
2	12	002-OFW-G007	WASHER, FLAT, .313 INCH, GALV.	0.01
3	6	002-OLW-G006	WASHER, SPLIT LOCK, .313 INCH, GALV	0.00
4	6	002-ONG-0007	NUT, HEX, .313"-18, GR 2H, GALV.	0.00
5	6	002-OBG-0214	BOLT, HX HD, .313-18UNC X 1.25 LG., GR. 5, GALV.	0.04
6	8	002-ONG-0010	NUT, HEX, .500-13UNC, GR 2H, GALV	0.06
7	4	002-OBG-0050	BOLT, HX HD, .500-13UNC, 1.50 LG, GR 5, GALV	0.13

SURFACE FINISH		UNLESS OTHERWISE SPECIFIED		APPROVALS		DATE	ELECTRO MECHANICAL INDUSTRIES, INC.	
✓ UNLESS OTHERWISE SPECIFIED		UNLESS OTHERWISE SPECIFIED		DRAWN		09.20.2018	11230 NEESEAW DRIVE	
MATERIAL		DIMENSIONS ARE IN INCHES		CHECKED		9.28.18	HOUSTON, TEXAS 77065	
SEE PARTS LIST		TOLERANCES		ENGINEER/DESIGNER		9.28.18	1-800-453-0050	
THIRD ANGLE PROJECTION		0 ± .06		PRODUCTION		9.28.18	TITLE:	
		.00 ± .01					2" MAST CANTENNA MOUNT KIT	
		.000 ± .005					SIZE	
		FRACTIONS ± 1/16					DRAWING NO.	
		ANGLES ± .25°					1000-0020-0022	
		HOLES:					REV	
		DRILLED OR PUNCHED					4	
		BURNED					SCALE: 1:2	
							WEIGHT: 4.65 lbs.	
							SHEET 1 OF 1	

NOTE: COLD GALVINIZE WORKED AREA AFTER COMPLETION