

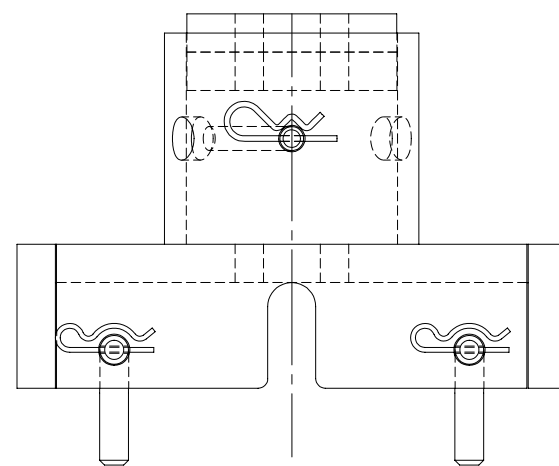

THE INFORMATION CONTAINED IN THIS DRAWING IS THE SOLE PROPERTY OF ELECTRO MECHANICAL INDUSTRIES, INC. ANY REPRODUCTION IN PART OR WHOLE WITHOUT THE WRITTEN PERMISSION OF ELECTRO MECHANICAL IND., IS PROHIBITED.

REVISIONS					
REV.	DCN #	DESCRIPTION	DATE	BY	APPROVED
3	01208	(9-3/4") WAS (8-5/8"), (1") WAS (7/8"), UPDATED WITH LOWER LEVEL CHANGES.	01/13/2023	JTR	JPB

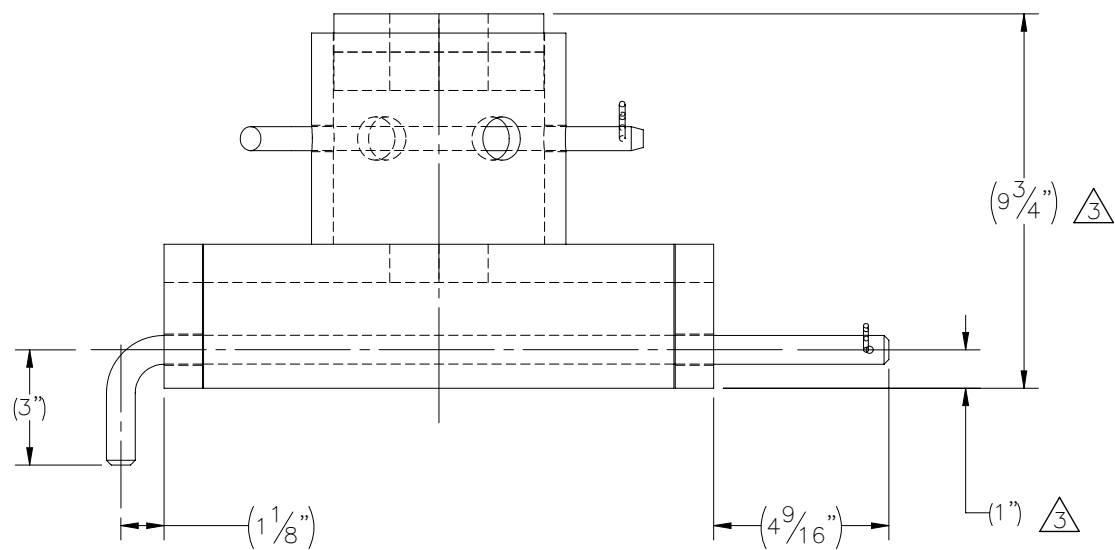
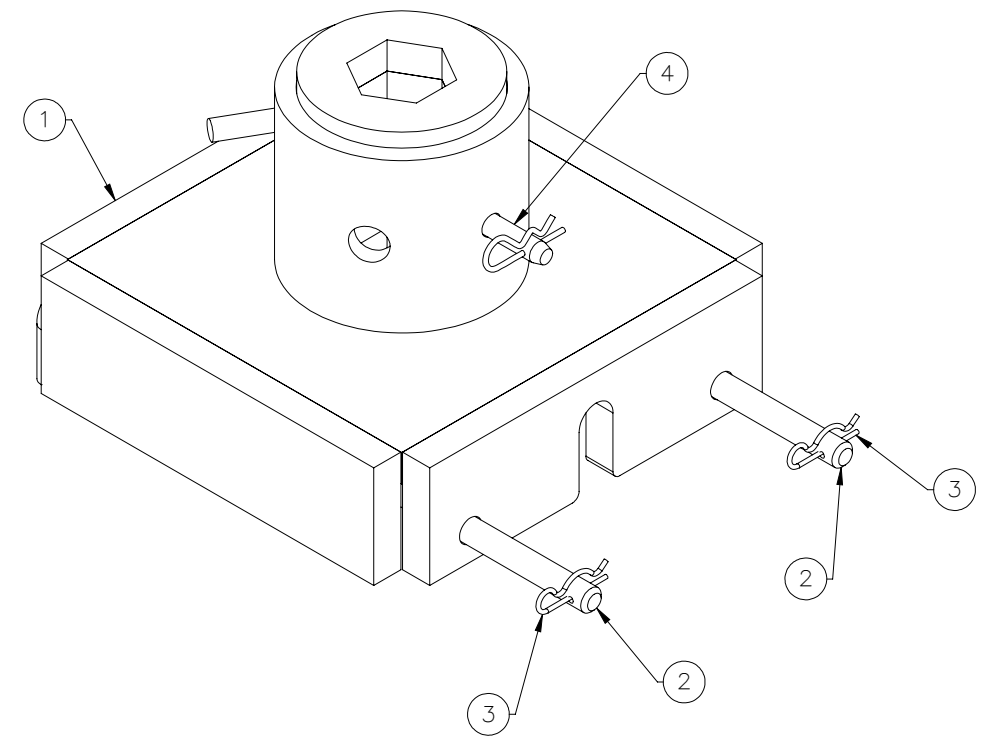
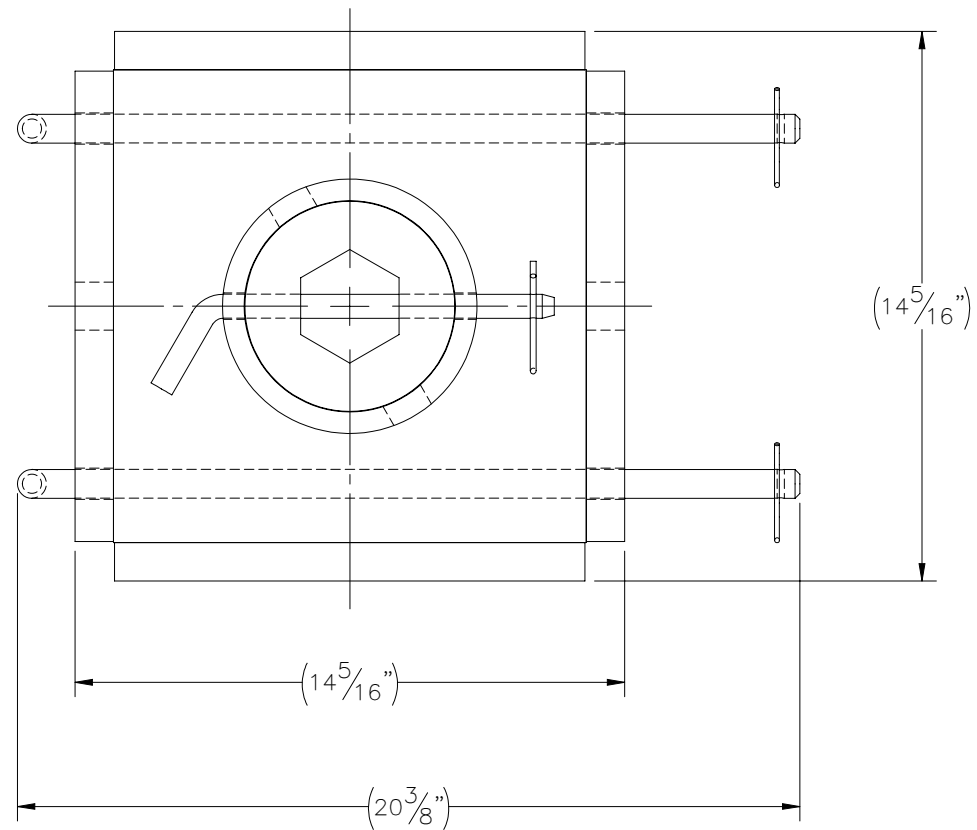

ITEM NO.	QTY REQD	PART NUMBER	DESCRIPTION	LENGTH	WEIGHT
1	1	W-000-870	2-1/2" DRIVE TOOL WELDMENT		76.1
2	2	P-002-140	DRIVE TOOL SECURING PIN		2.8
3	2	002-00C-0057	.125" WIRE DIA., 2.5" LG, REUSABLE HAIR PIN, ZINC PLD		0.0
4	1	002-00C-0058	CLEVIS PIN, .625 DIA X 8 USABLE, ZINC		

SURFACE FINISH <input checked="" type="checkbox"/> UNLESS OTHERWISE SPECIFIED		UNLESS OTHERWISE SPECIFIED DIMENSIONS ARE IN INCHES		APPROVALS		DATE		 ELECTRO MECHANICAL INDUSTRIES, INC. 11230 NEESESHAW DRIVE HOUSTON, TEXAS 77065 1-800-453-0050	
MATERIAL SEE PARTS LIST		TOLERANCES		DRAWN		DATE			
THIRD ANGLE PROJECTION 		.0 ±.06		RLWjr		3/30/2019		TITLE: 2-1/2" HEX DRIVE TOOL ASSY' KIT, 6"/8" HELICAL	
		.000 ±.005		CHECKER		3/21/2019			
		FRACTIONS ± 1/16		ENGINEER		3/22/2019			
		ANGLES ±.25°		PRODUCTION		3/22/2019			
NEXT ASSY		USED ON		DRILLED OR PUNCHED		HOLES:		SIZE B DRAWING NO. 1000-0020-0040 REV 3	
APPLICATIONS		BURNED ±1/32						SCALE: 1:5 WEIGHT: 81.9 lbs. SHEET 1 OF 1	