

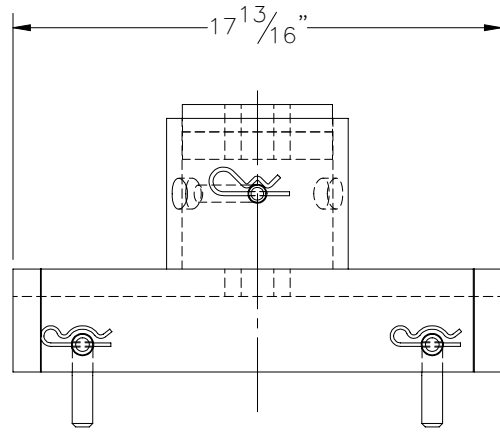

THE INFORMATION CONTAINED IN THIS DRAWING IS THE SOLE PROPERTY OF ELECTRO MECHANICAL INDUSTRIES, INC. ANY REPRODUCTION IN PART OR WHOLE WITHOUT THE WRITTEN PERMISSION OF ELECTRO MECHANICAL IND., IS PROHIBITED.

REVISIONS					
REV.	DCN #	DESCRIPTION	DATE	BY	APPROVED
3	01208	(9-3/4") WAS (8-5/8"), UPDATED WITH LOWER LEVEL CHANGES.	01/30/2023	JTR	JPB

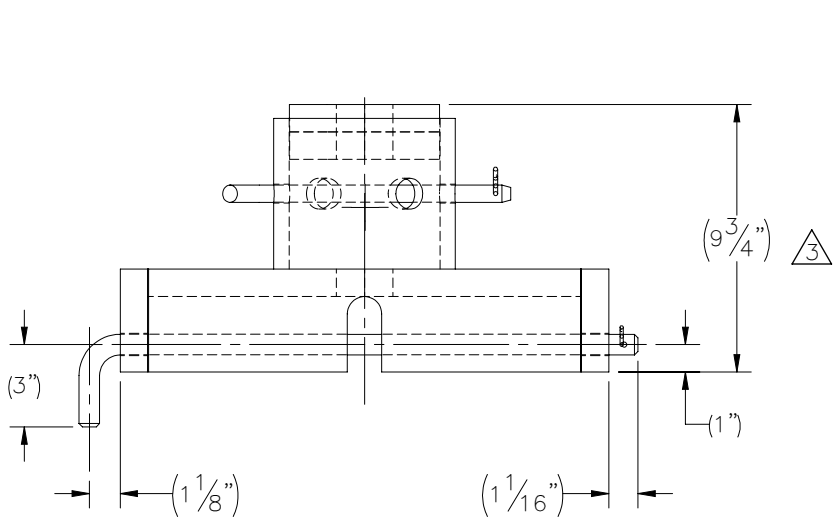
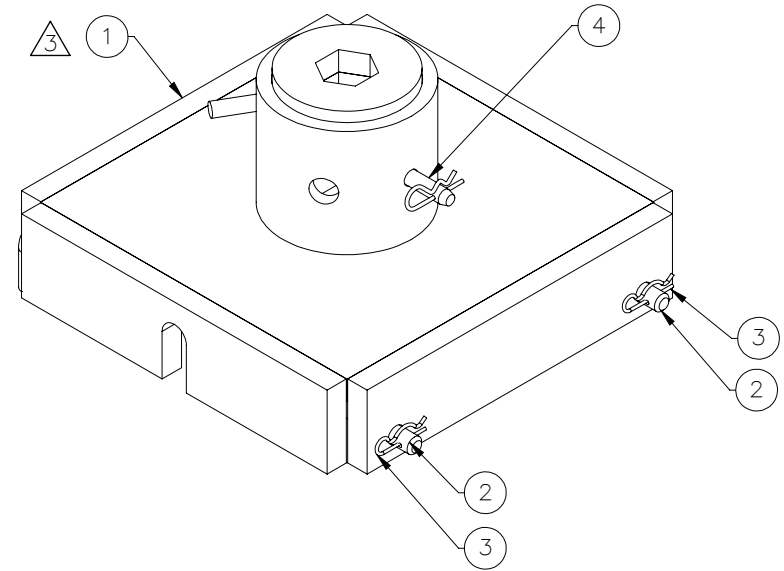
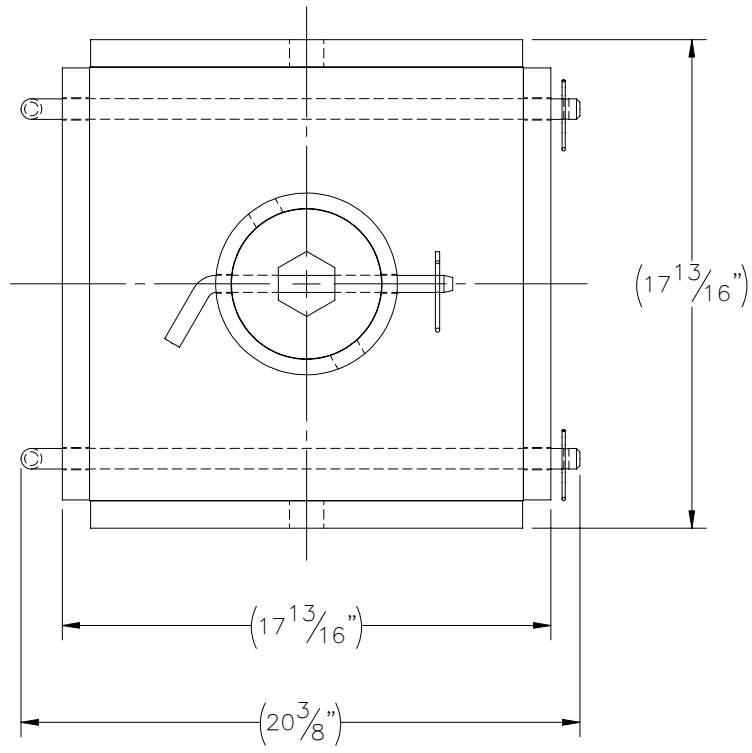

ITEM NO.	QTY REQD	PART NUMBER	DESCRIPTION	LENGTH	WEIGHT
1	1	W-001-299	2" DRIVE TOOL WELDMENT		161.9
2	2	P-002-140	DRIVE TOOL SECURING PIN		2.8
3	2	002-00C-0057	.125" WIRE DIA., 2.5" LG, REUSABLE HAIR PIN, ZINC PLD		0.0
4	1	002-00C-0058	CLEVIS PIN, .625 DIA X 8 USABLE, ZINC		

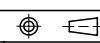
SURFACE FINISH <input checked="" type="checkbox"/> UNLESS OTHERWISE SPECIFIED		UNLESS OTHERWISE SPECIFIED DIMENSIONS ARE IN INCHES		APPROVALS		DATE		 ELECTRO MECHANICAL INDUSTRIES, INC. 11230 NEESESHAW DRIVE HOUSTON, TEXAS 77065 1-800-453-0050	
MATERIAL SEE PARTS LIST		TOLERANCES		DRAWN		DATE			
THIRD ANGLE PROJECTION 		.0 ±.06 .00 ±.015 .000 ±.005		CHECKER		DATE		TITLE: <b>2" HEX DRIVE TOOL ASSY'                  KIT, 10" HELICAL</b>	
NEXT ASSY USED ON		FRACTIONS ± 1/16 ANGLES ± .25°		ENGINEER		DATE			
APPLICATIONS		HOLES: DRILLED OR PUNCHED ± 1/32 BURNED ± 1/32		PRODUCTION		DATE			
				J. SUNDERLAND		3/22/2019		SIZE <b>B</b> DRAWING NO. 1000-0020-0041 REV 3 SCALE: 1:7 WEIGHT: 167.7 lbs. SHEET 1 OF 1	