

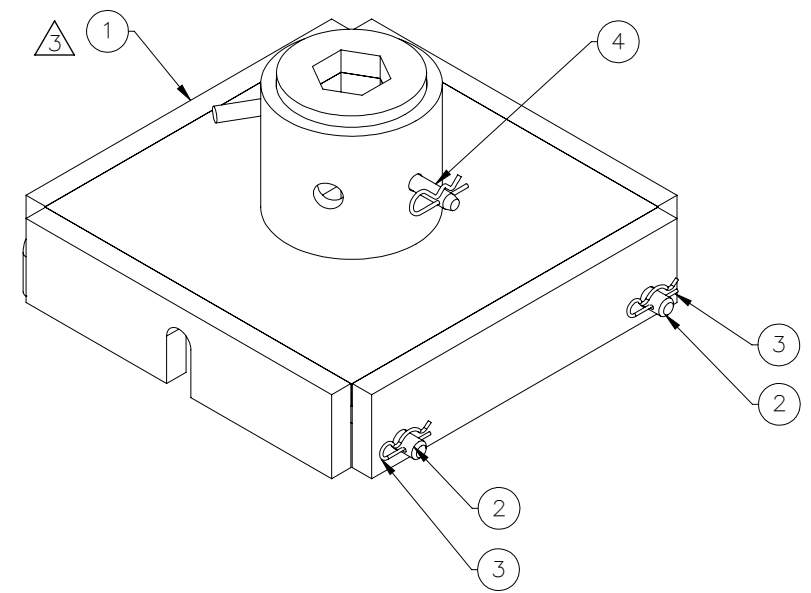

THE INFORMATION CONTAINED IN THIS DRAWING IS THE SOLE PROPERTY OF ELECTRO MECHANICAL INDUSTRIES, INC. ANY REPRODUCTION IN PART OR WHOLE WITHOUT THE WRITTEN PERMISSION OF ELECTRO MECHANICAL IND., IS PROHIBITED.

REVISIONS					
REV.	DCN #	DESCRIPTION	DATE	BY	APPROVED
3	01208	(9-3/4") WAS (8-5/8"), UPDATED WITH LOWER LEVEL CHANGES.	01/30/2023	JTR	JPB

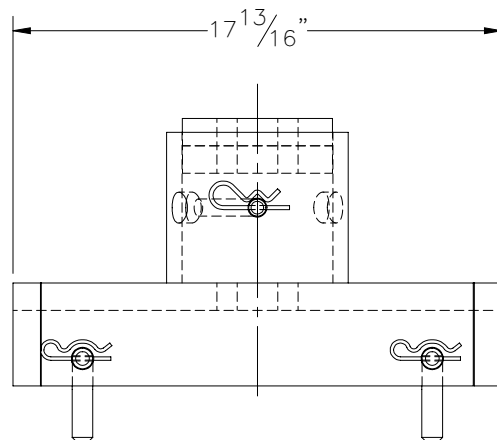
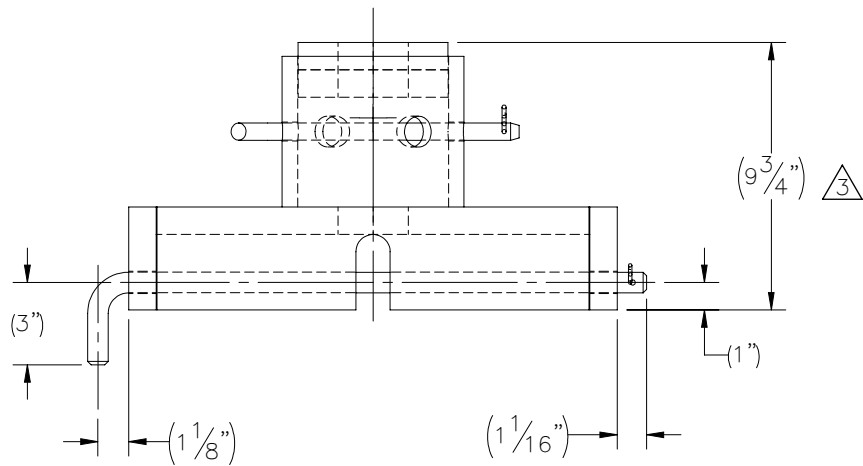
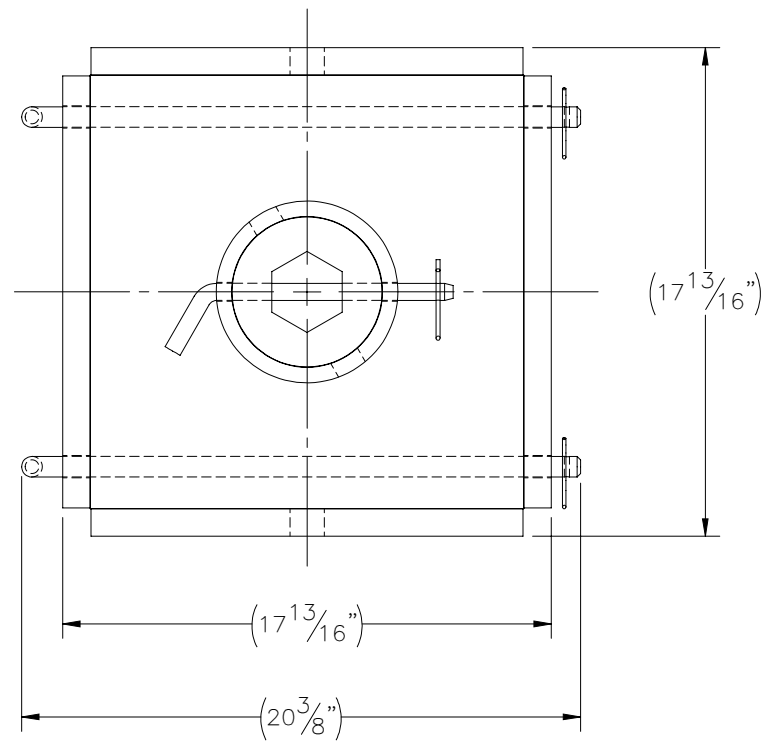

ITEM NO.	QTY REQD	PART NUMBER	DESCRIPTION	LENGTH	WEIGHT
1	1	W-001-300	2-1/2" DRIVE TOOL WELDMENT		160.2
2	2	P-002-140	DRIVE TOOL SECURING PIN		2.8
3	2	002-00C-0057	.125" WIRE DIA., 2.5" LG, REUSABLE HAIR PIN, ZINC PLD		0.0
4	1	002-00C-0058	CLEVIS PIN, .625 DIA X 8 USABLE, ZINC		

SURFACE FINISH <input checked="" type="checkbox"/> UNLESS OTHERWISE SPECIFIED		UNLESS OTHERWISE SPECIFIED DIMENSIONS ARE IN INCHES		APPROVALS		DATE		 ELECTRO MECHANICAL INDUSTRIES, INC. 11230 NEESESHAW DRIVE HOUSTON, TEXAS 77065 1-800-453-0050	
MATERIAL SEE PARTS LIST		TOLERANCES .0 ± .06 .00 ± .015 .000 ± .005		DRAWN R. WOODARD		3/20/2019			
THIRD ANGLE PROJECTION 		FRACTIONS ± 1/16		CHECKER P. GUTIERREZ		3/21/2019		TITLE: 2-1/2" HEX DRIVE TOOL ASSY' KIT, 10" HELICAL	
NEXT ASSY USED ON		ANGLES ± .25°		ENGINEER J. BREEN		3/22/2019			
APPLICATIONS		HOLES: DRILLED OR PUNCHED ± 1/32		PRODUCTION J. SUNDERLAND		3/22/2019		SIZE B DRAWING NO. 1000-0020-0042 REV 3	
		BURNED ± 1/32		SCALE: 1:7		WEIGHT: 166.0 lbs.		SHEET 1 OF 1	