

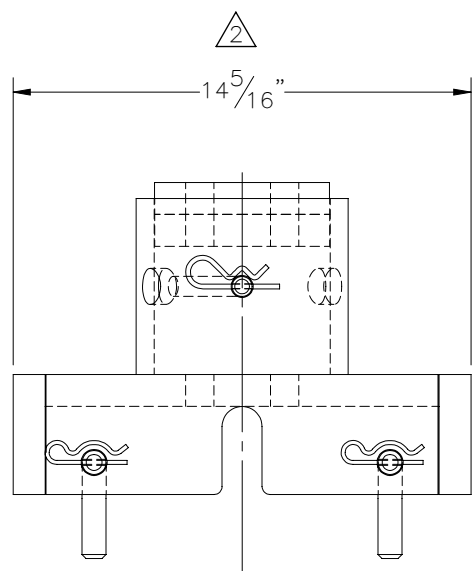

THE INFORMATION CONTAINED IN THIS DRAWING IS THE SOLE PROPERTY OF ELECTRO MECHANICAL INDUSTRIES, INC. ANY REPRODUCTION IN PART OR WHOLE WITHOUT THE WRITTEN PERMISSION OF ELECTRO MECHANICAL IND., IS PROHIBITED.

REVISIONS					
REV.	DCN #	DESCRIPTION	DATE	BY	APPROVED
2	01208	14-5/16" WAS 14-1/2", (4-9/16") WAS (4-3/8"), (9-3/4") WAS (8-5/8"), (14-5/16") WAS (14-1/2"), UPDATED WITH LOWER LEVEL CHANGES.	01/30/2023	JTR	JPB

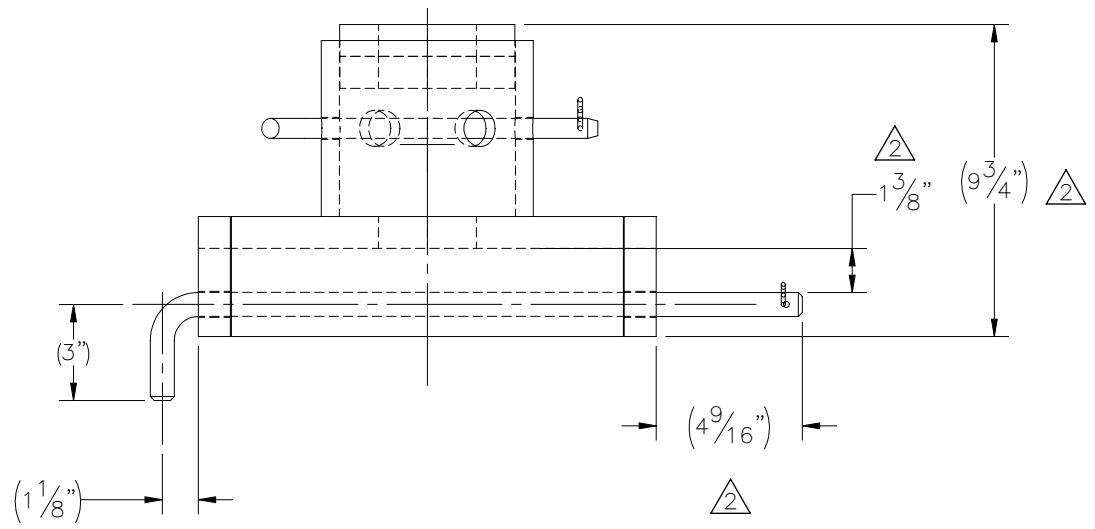
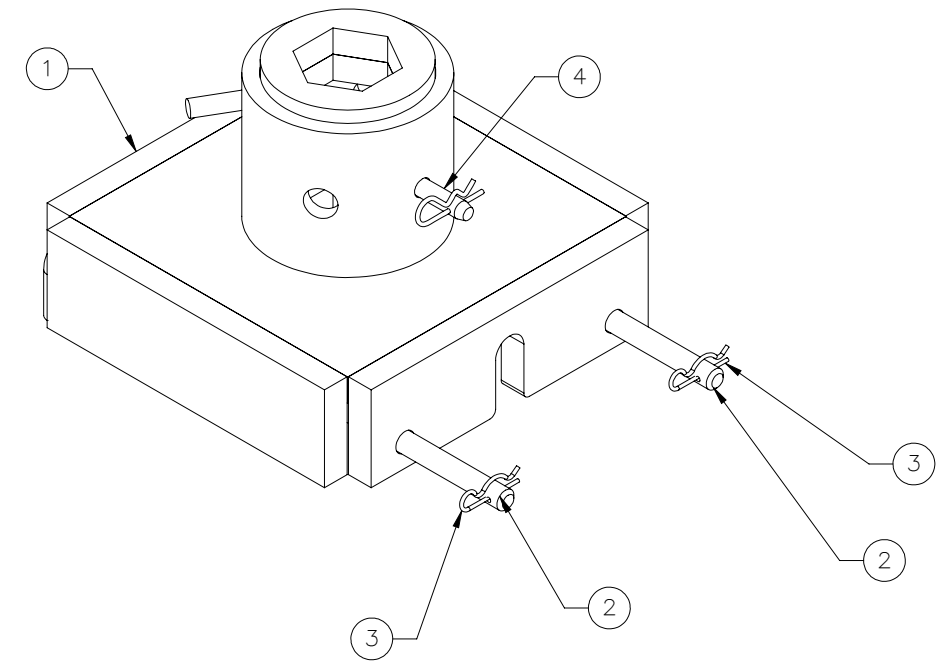
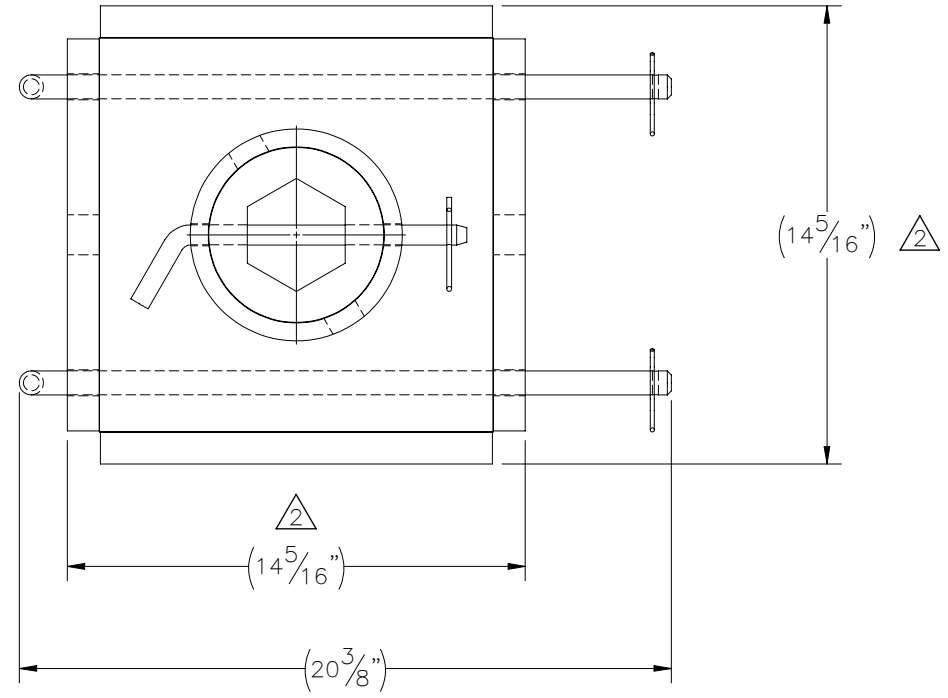

ITEM NO.	QTY REQD	PART NUMBER	DESCRIPTION	LENGTH	WEIGHT
1	1	W-002-163	3" DRIVE TOOL WELDMENT, 6" HELICAL		115.3
2	2	P-002-140	DRIVE TOOL SECURING PIN		2.8
3	2	002-00C-0057	.125" WIRE DIA., 2.5" LG, REUSABLE HAIR PIN, ZINC PLD		0.0
4	1	002-00C-0058	CLEVIS PIN, .625 DIA X 8 USABLE, ZINC		

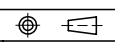
SURFACE FINISH <input checked="" type="checkbox"/> UNLESS OTHERWISE SPECIFIED		UNLESS OTHERWISE SPECIFIED DIMENSIONS ARE IN INCHES		APPROVALS		DATE		 ELECTRO MECHANICAL INDUSTRIES, INC. 11230 NEESESHAW DRIVE HOUSTON, TEXAS 77065 1-800-453-0050	
MATERIAL SEE PARTS LIST		TOLERANCES		DRAWN		4/6/2021			
THIRD ANGLE PROJECTION 		.0 ±.06 .00 ±.015 .000 ±.005		CHECKER		4/6/2021		TITLE: 3" HEX DRIVE TOOL ASSY' KIT, 6"/8" HELICAL	
NEXT ASSY USED ON		FRACTIONS ± 1/16 ANGLES ± .25°		ENGINEER		4/6/2021			
APPLICATIONS		HOLES: DRILLED OR PUNCHED ± 1/32 BURNED ± 1/32		PRODUCTION		4/6/2021		SIZE B DRAWING NO. 1000-0020-0085 REV 2 SCALE: 1:6 WEIGHT: 121.1 lbs. SHEET 1 OF 1	