

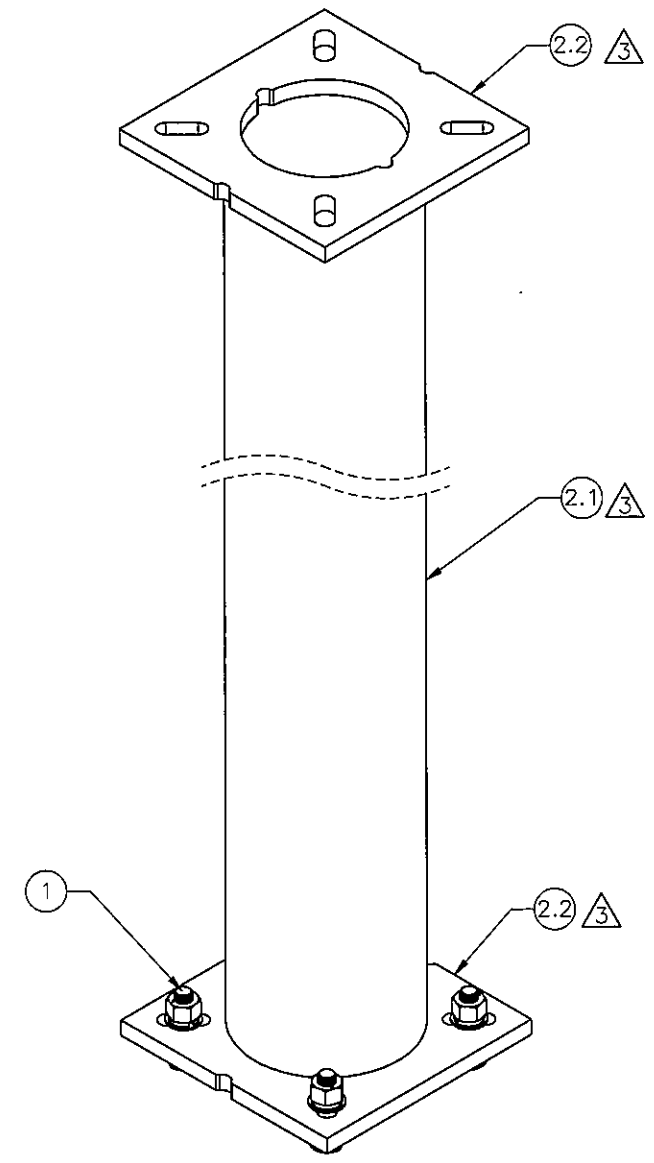

THE INFORMATION CONTAINED IN THIS DRAWING IS THE SOLE PROPERTY OF ELECTRO MECHANICAL INDUSTRIES, INC. ANY REPRODUCTION IN PART OR WHOLE WITHOUT THE WRITTEN PERMISSION OF ELECTRO MECHANICAL IND., IS PROHIBITED.

REVISIONS					
REV.	DCN #	DESCRIPTION	DATE	BY	APPROVED
3	01032	CREATED SUB-B.O.M FOR WELDMENT	4/13/2021	PG	JPB

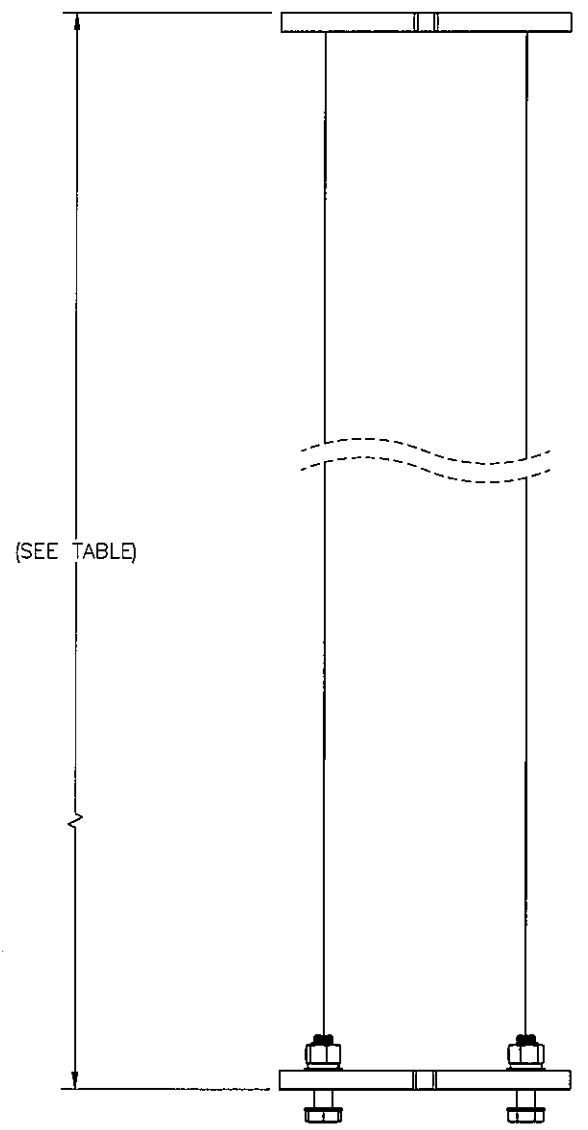

ITEM NO.	QTY REQD	PART NUMBER	DESCRIPTION	LENGTH	WEIGHT
1	1	1000-0020-0079	1" X 4" MOUNTING HARDWARE KIT		8
2	1	1007-T010-0000-W	10" EXTENSION WELDMENT	SEE TABLE	SEE TABLE
2.1	1	1007-T010-0000_1	HSS 10.75 X 0.365, ASTM A500, 42 KSI MIN. YIELD	SEE TABLE	SEE TABLE
2.2	2	P-000-184	TOP PLATE	15 1/2"	46.50

SURFACE FINISH <input checked="" type="checkbox"/> UNLESS OTHERWISE SPECIFIED		UNLESS OTHERWISE SPECIFIED DIMENSIONS ARE IN INCHES		APPROVALS		DATE		 ELECTRO MECHANICAL INDUSTRIES, INC. 11230 NEESHAW DRIVE HOUSTON, TEXAS 77065 1-800-453-0050	
MATERIAL SEE PARTS LIST		TOLERANCES		DRAWN J. CRIELLI		7/18/2017			
THIRD ANGLE PROJECTION 		.0 ± .06		CHECKER C. SANCHEZ		10/31/2017		TITLE: 10" EXTENSION TABLE DRAWING	
		.000 ± .015		ENGINEER J. BUSHMAN		10/31/2017			
NEXT ASSY		FRACTIONS ± 1/6		PRODUCTION J. BOWLDS		10/31/2018			
USED ON		ANGLES ± .25°		SCALE: 1:10		WEIGHT: 297.0 lbs.		SHEET 1 OF 2	
APPLICATIONS		HOLES: DRILLED OR PUNCHED ± 1/32		DRAWING NO. 1007-T010-0000		REV 3			
		BURNED ± 1/32							

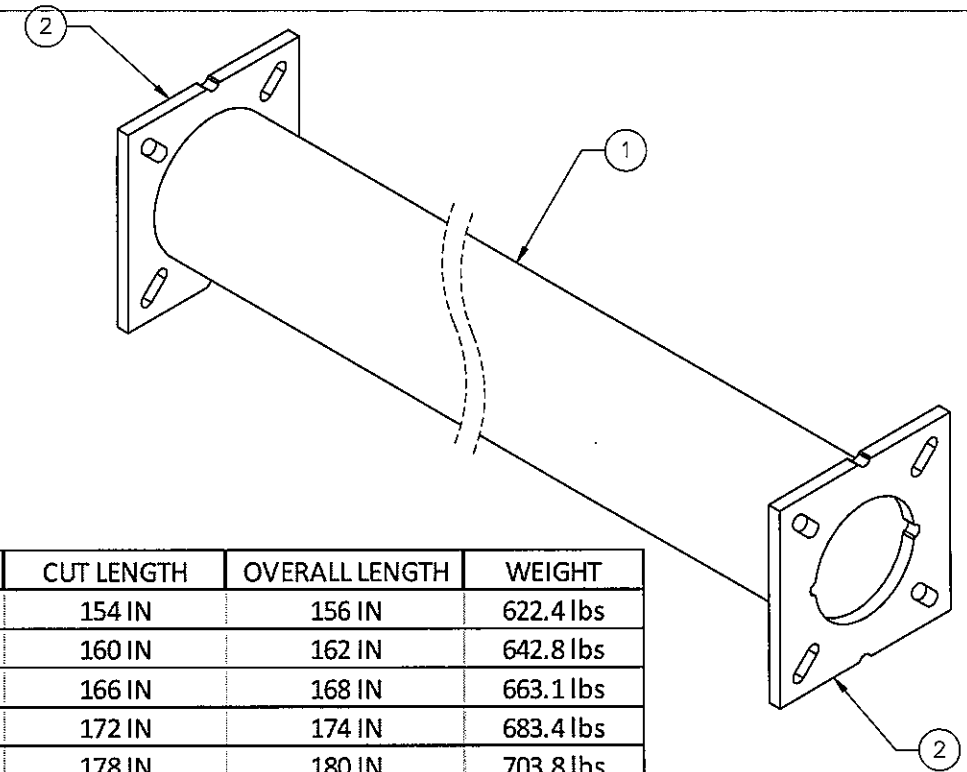
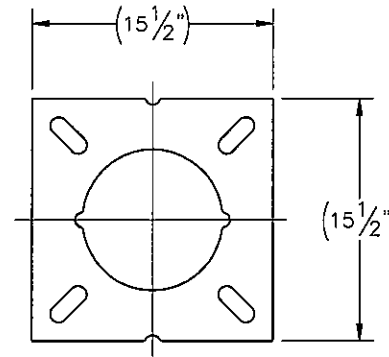
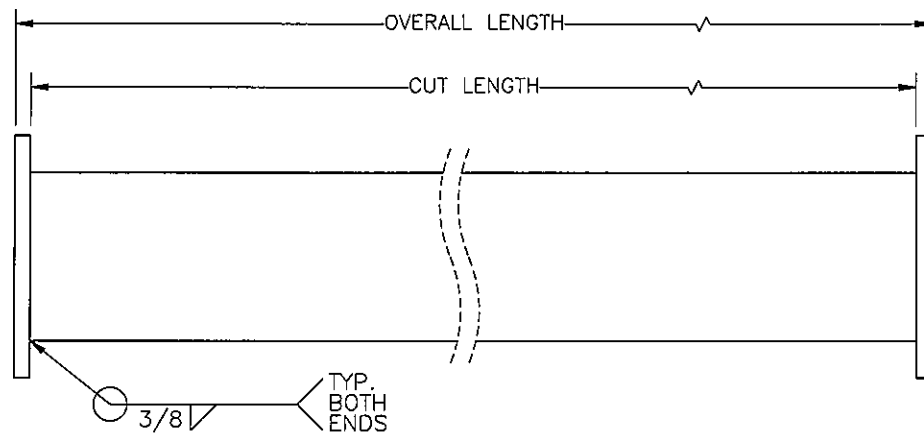

PART #	LEGACY #	DESCRIPTION	CUT LENGTH	OVERALL LENGTH	WEIGHT
1007-T010-0060		0.5 FT EXTENSION	4 IN	6 IN	114.6 lbs
1007-T010-0120	400-000-2005	1.0 FT EXTENSION	10 IN	12 IN	134.9 lbs
1007-T010-0180		1.5 FT EXTENSION	16 IN	18 IN	155.2 lbs
1007-T010-0240	400-000-2006	2.0 FT EXTENSION	22 IN	24 IN	175.5 lbs
1007-T010-0300		2.5 FT EXTENSION	28 IN	30 IN	195.8 lbs
1007-T010-0360	400-000-2007	3.0 FT EXTENSION	34 IN	36 IN	216.1 lbs
1007-T010-0420		3.5 FT EXTENSION	40 IN	42 IN	236.5 lbs
1007-T010-0480	400-000-2008	4.0 FT EXTENSION	46 IN	48 IN	256.8 lbs
1007-T010-0540		4.5 FT EXTENSION	52 IN	54 IN	277.1 lbs
1007-T010-0600	400-000-2009	5.0 FT EXTENSION	58 IN	60 IN	297.4 lbs
1007-T010-0660		5.5 FT EXTENSION	64 IN	66 IN	317.7 lbs
1007-T010-0720	400-000-2015	6.0 FT EXTENSION	70 IN	72 IN	338.0 lbs
1007-T010-0780		6.5 FT EXTENSION	76 IN	78 IN	358.4 lbs
1007-T010-0840	400-000-2016	7.0 FT EXTENSION	82 IN	84 IN	378.7 lbs
1007-T010-0900		7.5 FT EXTENSION	88 IN	90 IN	399.0 lbs
1007-T010-0960	400-000-2017	8.0 FT EXTENSION	94 IN	96 IN	419.3 lbs
1007-T010-1020		8.5 FT EXTENSION	100 IN	102 IN	439.6 lbs
1007-T010-1080	400-000-2018	9.0 FT EXTENSION	106 IN	108 IN	459.9 lbs
1007-T010-1140		9.5 FT EXTENSION	112 IN	114 IN	480.2 lbs
1007-T010-1200	400-000-2010	10.0 FT EXTENSION	118 IN	120 IN	500.6 lbs
1007-T010-1260		10.5 FT EXTENSION	124 IN	126 IN	520.9 lbs
1007-T010-1320	400-000-2011	11.0 FT EXTENSION	130 IN	132 IN	541.2 lbs
1007-T010-1380		11.5 FT EXTENSION	136 IN	138 IN	561.5 lbs
1007-T010-1440	400-000-2012	12.0 FT EXTENSION	142 IN	144 IN	581.8 lbs
1007-T010-1500		12.5 FT EXTENSION	148 IN	150 IN	602.1 lbs

PART #	LEGACY #	DESCRIPTION	CUT LENGTH	OVERALL LENGTH	WEIGHT
1007-T010-1560	400-000-2021	13.0 FT EXTENSION	154 IN	156 IN	622.4 lbs
1007-T010-1620		13.5 FT EXTENSION	160 IN	162 IN	642.8 lbs
1007-T010-1680	400-000-2019	14.0 FT EXTENSION	166 IN	168 IN	663.1 lbs
1007-T010-1740		14.5 FT EXTENSION	172 IN	174 IN	683.4 lbs
1007-T010-1800	400-000-2013	15.0 FT EXTENSION	178 IN	180 IN	703.8 lbs
1007-T010-1860		15.5 FT EXTENSION	184 IN	186 IN	724.0 lbs
1007-T010-1920	400-000-2022	16.0 FT EXTENSION	190 IN	192 IN	744.3 lbs
1007-T010-1980		16.5 FT EXTENSION	196 IN	198 IN	764.6 lbs
1007-T010-2040	400-000-2023	17.0 FT EXTENSION	202 IN	204 IN	785.0 lbs
1007-T010-2100		17.5 FT EXTENSION	208 IN	210 IN	805.3 lbs
1007-T010-2160	400-000-2020	18.0 FT EXTENSION	214 IN	216 IN	825.6 lbs
1007-T010-2220		18.5 FT EXTENSION	220 IN	222 IN	845.9 lbs
1007-T010-2280	400-000-2024	19.0 FT EXTENSION	226 IN	228 IN	866.2 lbs
1007-T010-2340		19.5 FT EXTENSION	232 IN	234 IN	886.5 lbs
1007-T010-2400	400-000-2014	20.0 FT EXTENSION	238 IN	240 IN	906.8 lbs
1007-T010-2460		20.5 FT EXTENSION	244 IN	246 IN	927.2 lbs
1007-T010-2520	400-000-2025	21.0 FT EXTENSION	250 IN	252 IN	947.5 lbs
1007-T010-2580		21.5 FT EXTENSION	256 IN	258 IN	967.8 lbs
1007-T010-2640	400-000-2026	22.0 FT EXTENSION	262 IN	264 IN	988.1 lbs
1007-T010-2700		22.5 FT EXTENSION	268 IN	270 IN	1008.4 lbs
1007-T010-2760	400-000-2027	23.0 FT EXTENSION	274 IN	276 IN	1028.7 lbs
1007-T010-2820		23.5 FT EXTENSION	280 IN	282 IN	1049.1 lbs
1007-T010-2880	400-000-2028	24.0 FT EXTENSION	286 IN	288 IN	1069.4 lbs
1007-T010-2940		24.5 FT EXTENSION	292 IN	294 IN	1089.7 lbs
1007-T010-3000	400-000-2029	25.0 FT EXTENSION	298 IN	300 IN	1110.0 lbs

NOTES:
UNLESS OTHERWISE SPECIFIED,

- ALL WELDING PER AWS D1.1, FCAW, E7XT-1 AND GMAW, ER70S-6 ELECTRODES.
- SQUARENESS OF WELDED COMPONENTS TO BE WITHIN +/- 1/16".
- ALL WELDS 3/16" FILLET OR SEAM WELDS ALL AROUND AS APPLICABLE PER JOINT.
- ALL CAPTIVE TUBES MUST HAVE MIN. TWO WEEP HOLES (ONE UPPER, ONE LOWER) 7/16" DIA.
- GALVANIZE PER ASTM A123.

EMI ELECTRO MECHANICAL INDUSTRIES, INC.
11230 NEESEY DRIVE
HOUSTON, TEXAS 77065
1-800-453-0050

SIZE B DRAWING NO. 1007-T010-0000 REV 3
SCALE: 1:12 SHEET 2 OF 2