

THE INFORMATION CONTAINED IN THIS DRAWING IS THE SOLE PROPERTY OF ELECTRO MECHANICAL INDUSTRIES, INC. ANY REPRODUCTION IN PART OR WHOLE WITHOUT THE WRITTEN PERMISSION OF ELECTRO MECHANICAL IND., IS PROHIBITED.

REVISIONS					
REV.	DCN #	DESCRIPTION	DATE	BY	APPROVED
3	01005	T010-0357-1044 WAS P-001-810	5/12/2021	BLH	JPB

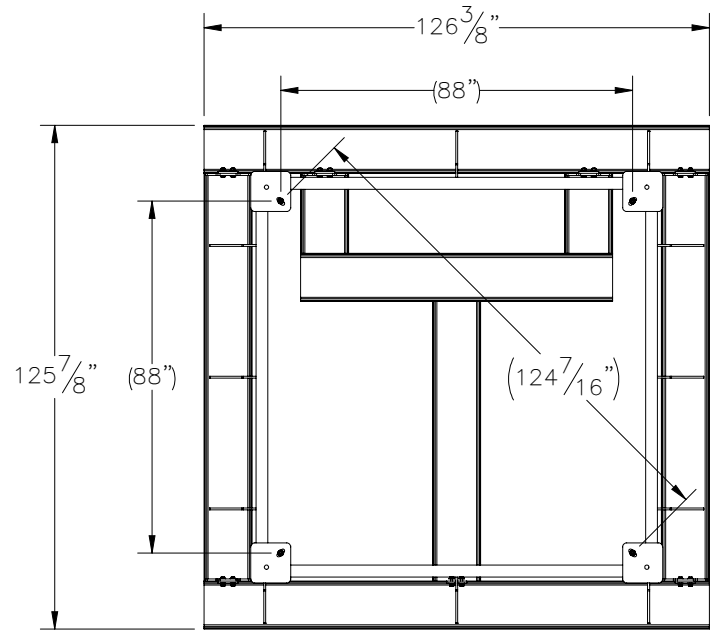

GRATING HIDDEN FOR CLARITY

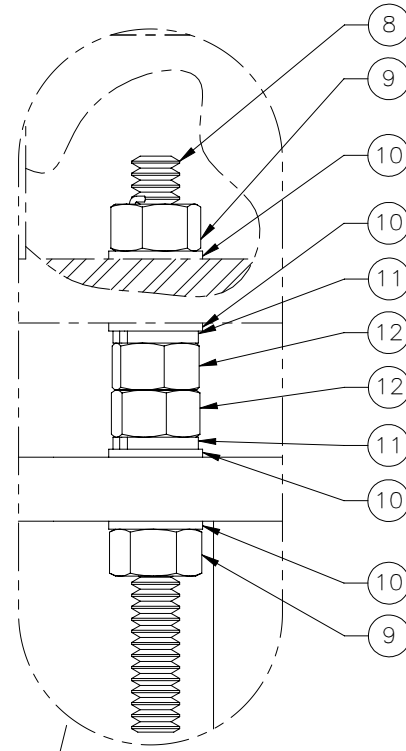

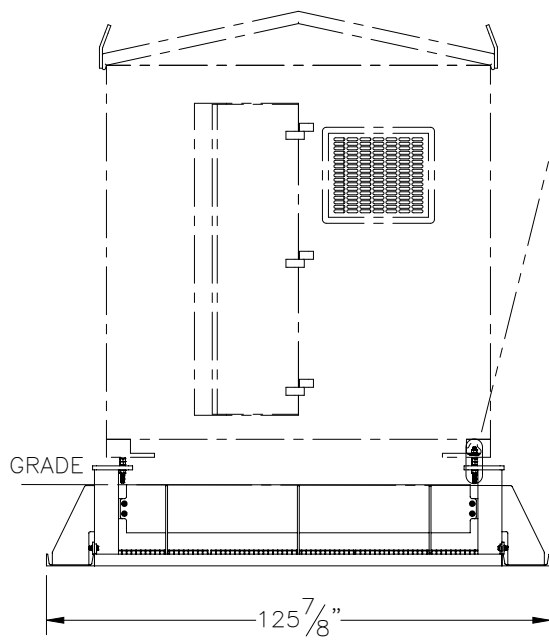
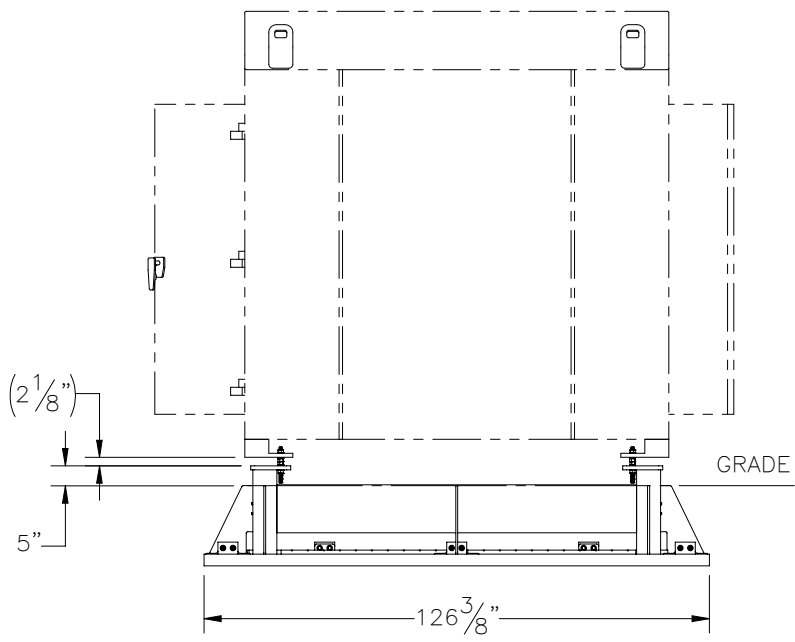

TYP LEVELING HARDWARE
DETAIL 4X

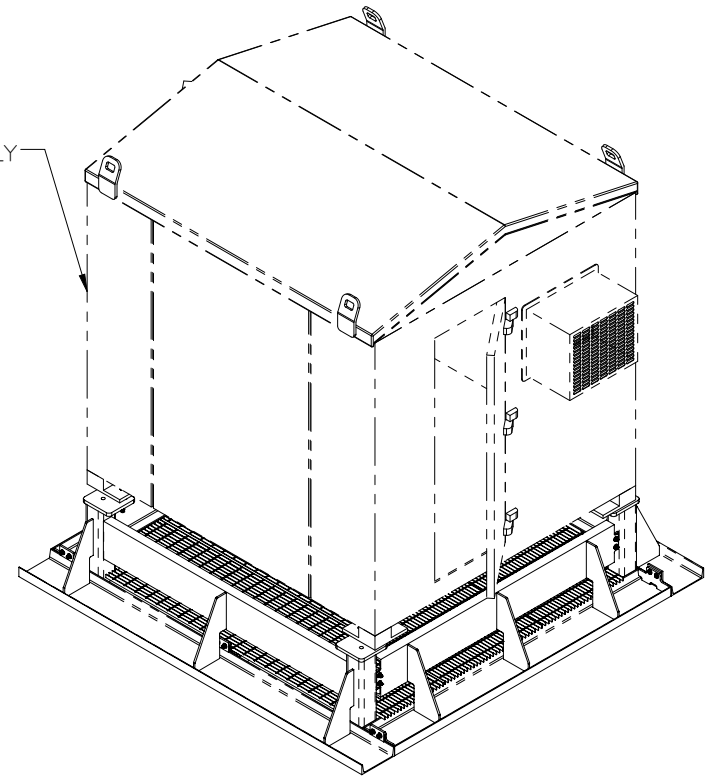

HUT SHOWN FOR REPRESENTATION ONLY



ITEM NO.	QTY REQD	PART NUMBER	DESCRIPTION	LENGTH	WEIGHT
1	1	W-000-709	8X8 HUT FOUNDATION BACK SIDE WELDMENT		637.56
2	1	W-000-710	8X8 HUT FOUNDATION FRONT SIDE WELDMENT		635.50
3	2	W-000-711	8X8 HUT FOUNDATION SIDE WELDMENT		395.66
4	1	W-000-713	8X8 HUT CENTER GRATING SUPPORT WELDMENT		340.32
5	1	P-001-804	GRATING PANEL	104 11/16"	163.14
6	1	P-001-805	GRATING PANEL	104 11/16"	134.69
7	1	T010-0357-1044	GRATING PANEL, 1" THK SMOOTH, 31 BAR, 35.8125 WIDTH	104 1/2"	182.0
8	4	002-OAT-HA05	ROD, THREADED, .75-10UNC X 9.00 LG, ASTM A193 B7, GALV.		0.834
9	8	002-ONG-0016	NUT, HX, ANCO LOCKNUT, .75-10UNC, GR 2H, GALV		0.19
10	16	002-OFW-G003	FW, .75 F436, HDG		0.04
11	8	002-OLW-G003	WASHER, SPLIT LOCK, .75, GALV		0.05
12	8	002-ONG-0002	NUT, HX, .75-10UNC, GR 2H, GALV		0.19
13	22	002-OBG-0014	BOLT HX. HD., .500-13UNC X 2.0" LG, ASTM A325, GALV.	2.00	0.2
14	44	002-OFW-G020	WASHER, FLAT, .500", USS, GALV		0.04
15	22	002-OLW-G002	WASHER, SPLIT LOCK, .500", GALV		0.01
16	22	002-ONG-0010	NUT, HEX, .500-13UNC, GR 2H, GALV		0.06

SURFACE FINISH <input checked="" type="checkbox"/> UNLESS OTHERWISE SPECIFIED		UNLESS OTHERWISE SPECIFIED DIMENSIONS ARE IN INCHES		APPROVALS		DATE		 ELECTRO MECHANICAL INDUSTRIES, INC. 11230 NEESESHAW DRIVE HOUSTON, TEXAS 77065 1-800-453-0050	
MATERIAL SEE PARTS LIST		TOLERANCES		DRAWN J. CRITELLI		10/30/2017		TITLE: BURIED FRAME, 8X8 HUT FOUNDATION	
THIRD ANGLE PROJECTION 		.0 ±.06 .00 ±.015 .000 ±.005		CHECKER J. BUSHMAN		10/30/2017		SIZE B	
NEXT ASSY USED ON		FRACTIONS ± 1/16 ANGLES ± .25°		ENGINEER J. BUSHMAN		10/30/2017		DRAWING NO. 1008-0000-0001	
APPLICATIONS		HOLES: DRILLED OR PUNCHED ± 1/32 BURNED ± 1/32		PRODUCTION J. BOWLDS		10/30/2017		REV 3	
				SCALE: 1:48		WEIGHT: 2899.25 lbs.		SHEET 1 OF 3	

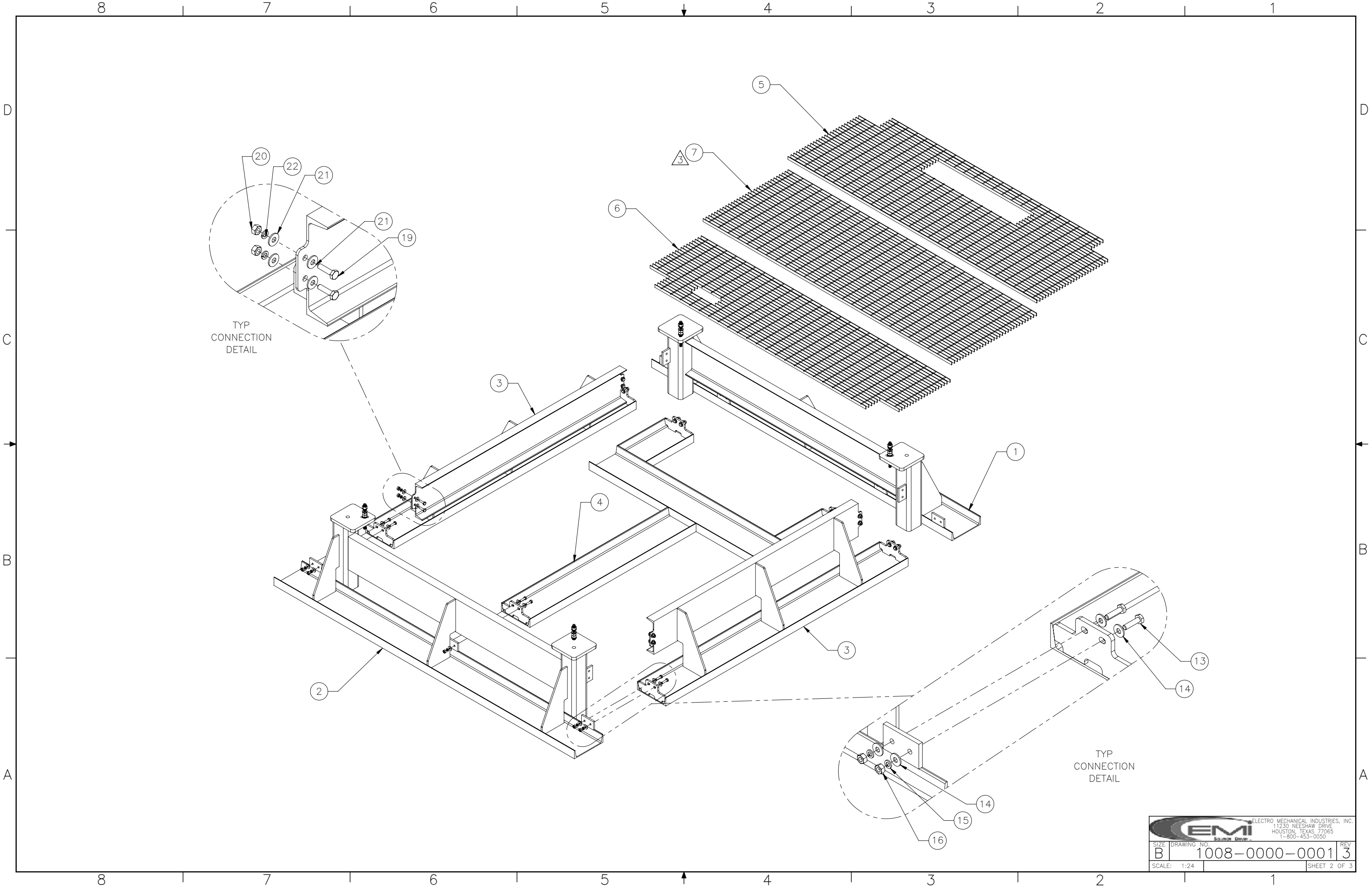

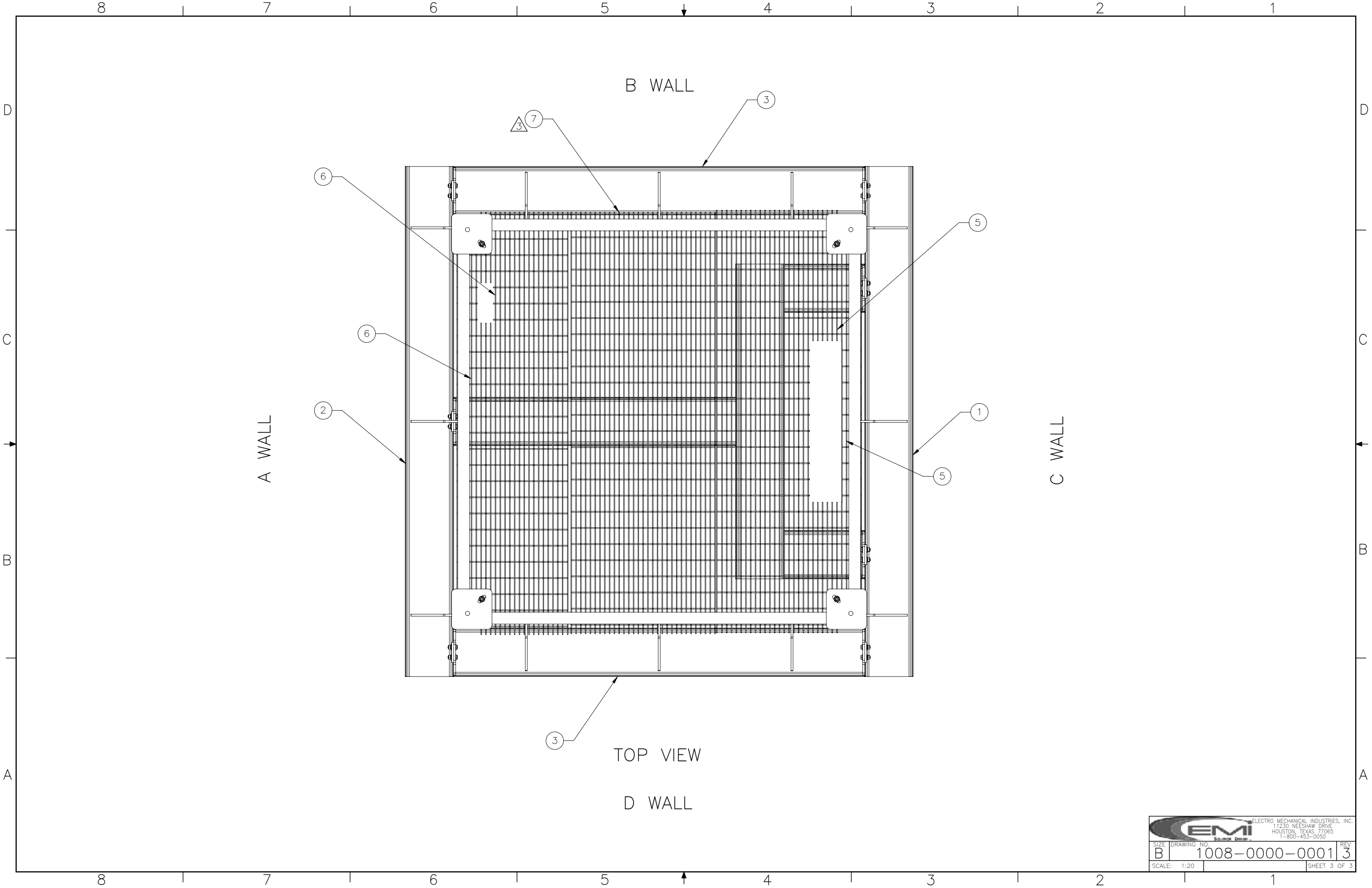

A WALL

B WALL

C WALL

TOP VIEW

D WALL

		ELECTRO MECHANICAL INDUSTRIES, INC. 11230 NEESHAW DRIVE HOUSTON, TEXAS 77065 1-800-453-0050	
SIZE	DRAWING NO.	REV.	
B	1008-0000-0001	3	
SCALE: 1:20		SHEET 3 OF 3	