

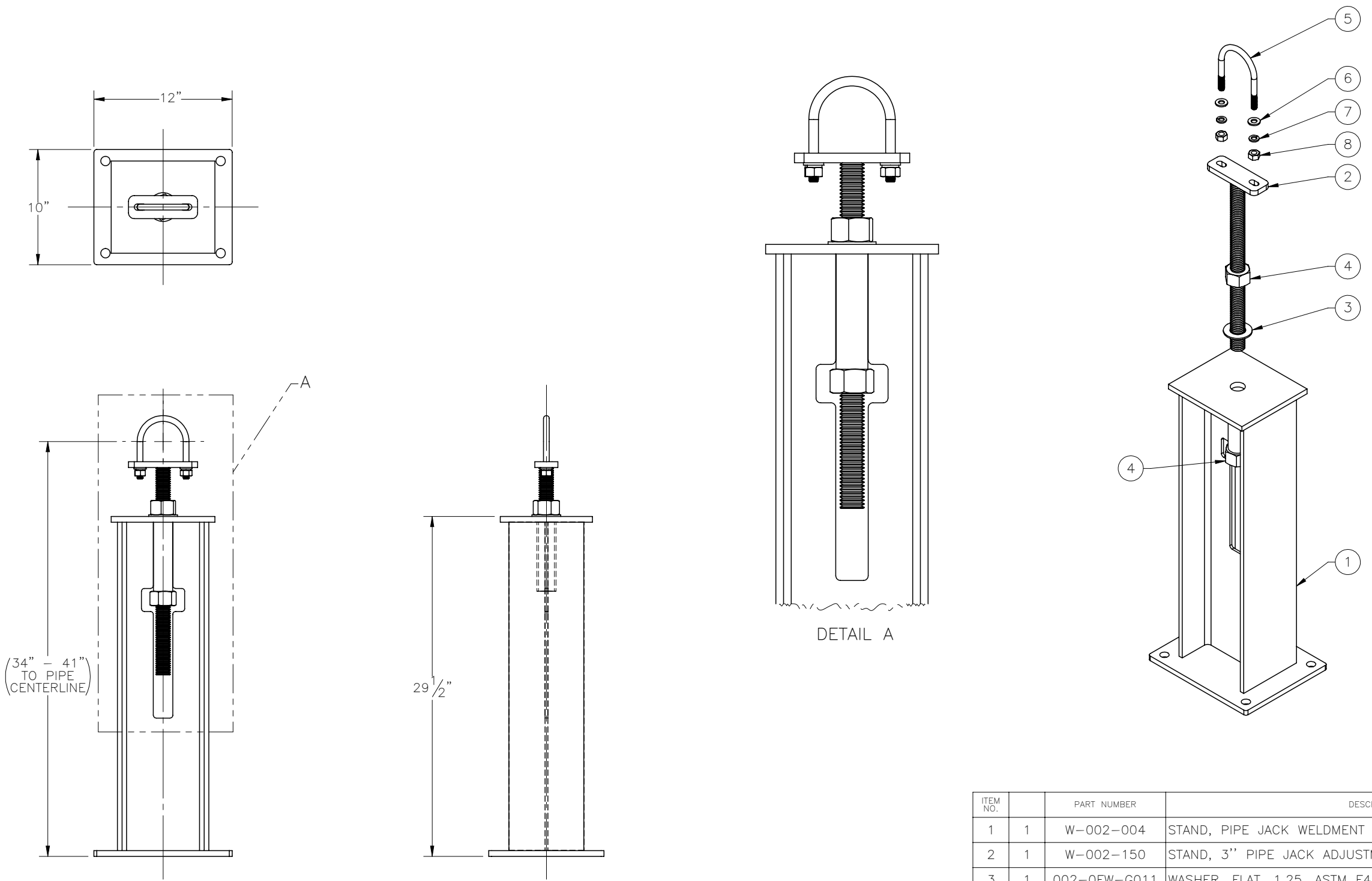

THE INFORMATION CONTAINED IN THIS DRAWING IS THE SOLE PROPERTY OF ELECTRO MECHANICAL INDUSTRIES, INC. ANY REPRODUCTION IN PART OR WHOLE WITHOUT THE WRITTEN PERMISSION OF ELECTRO MECHANICAL IND., IS PROHIBITED.



ITEM NO.		PART NUMBER	DESCRIPTION	LENGTH	WEIGHT
1	1	W-002-004	STAND, PIPE JACK WELDMENT FOR 36" PIPE ELEV.		82.8
2	1	W-002-150	STAND, 3" PIPE JACK ADJUSTMENT ROD		6.8
3	1	002-0FW-G011	WASHER, FLAT, 1.25, ASTM F436, GALV		0.13
4	2	002-0NG-0022	NUT, HEAVY HEX, 1-1/4"-7, GR 2H, GALV.		0.791
5	1	002-00U-G021	U-BOLT, .500-13 X 1.5 THD LG., 3.50 I.D. X 5.0 HT, ASTM A307, GALV.		0.09
6	2	002-0FW-G002	WASHER, FLAT, .500", F436, GALV		0.02
7	2	002-0LW-G002	WASHER, SPLIT LOCK, .500", GALV		0.01
8	2	002-0NG-0010	NUT, HEX, .500-13UNC, GR 2H, GALV		0.06

SURFACE FINISH <input checked="" type="checkbox"/> UNLESS OTHERWISE SPECIFIED		UNLESS OTHERWISE SPECIFIED DIMENSIONS ARE IN INCHES		APPROVALS	DATE	 ELECTRO MECHANICAL INDUSTRIES, INC. 11230 NEESESHAW DRIVE HOUSTON, TEXAS 77065 1-800-453-0050
MATERIAL	SEE PARTS LIST	TOLERANCES		DRAWN	3/17/2021	
THIRD ANGLE PROJECTION		.0 ±.06 .00 ±.015 .000 ±.005		CHECKER	3/17/2021	3" PIPE STAND FOUNDATION
		FRACTIONS ± 1/16 ANGLES ± .25°		ENGINEER	3/17/2021	
NEXT ASSY	USED ON	HOLES: DRILLED OR PUNCHED ± 1/32 BURNED ± 1/32		PRODUCTION	3/18/2021	
APPLICATIONS				JKS		SIZE B DRAWING NO. 1008-0000-0026 REV - SCALE: 1:4 WEIGHT: 91.6 lbs. SHEET 1 OF 1