

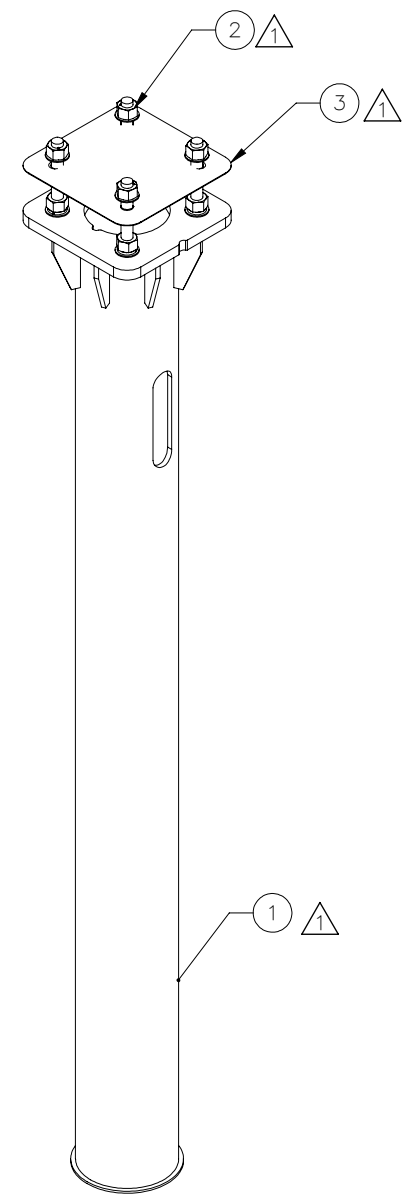

THE INFORMATION CONTAINED IN THIS DRAWING IS THE SOLE PROPERTY OF ELECTRO MECHANICAL INDUSTRIES, INC. ANY REPRODUCTION IN PART OR WHOLE WITHOUT THE WRITTEN PERMISSION OF ELECTRO MECHANICAL IND., IS PROHIBITED.

REVISIONS					
REV.	DCN #	DESCRIPTION	DATE	BY	APPROVED
1	DCN01214	REPLACED LEVELING KIT 1000-0020-0078 WITH 1000-0020-0113 AND ADDED LEVELING PLATE P-006-750	01.26.2023	RLWjr	FJM

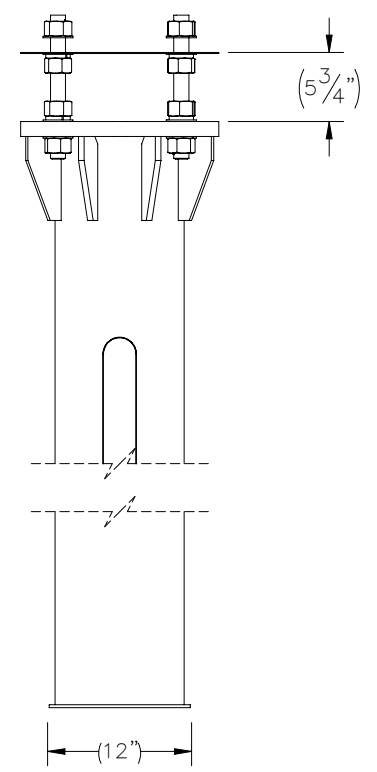
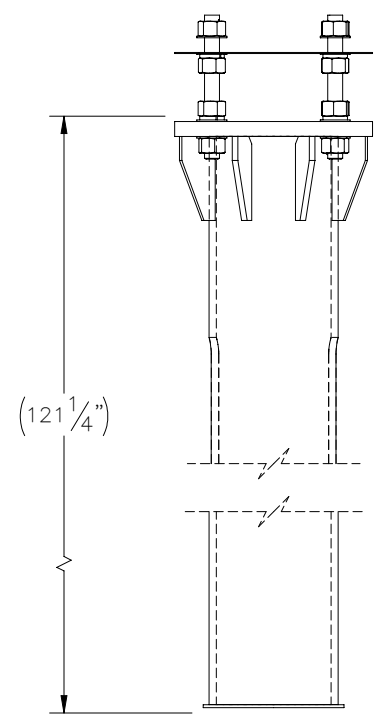
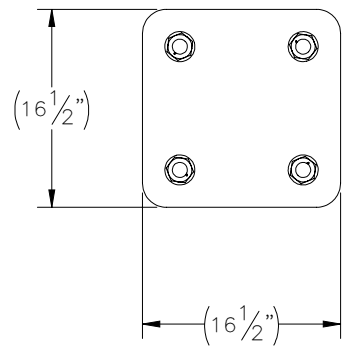

ITEM NO.	QTY REQD	PART NUMBER	DESCRIPTION	LENGTH	WEIGHT
1	1	W-002-548	10"DIA X 10' DIRECT BURIAL FOUNDATION WELDMENT		727.7
2	1	1000-0020-0113	QUAD 1.25" STUD LEVELING KIT, 12" LG.		32.9
3	1	P-006-750	LEVELING PLATE, 14 GA. THK.	16 1/2"	5.97

SURFACE FINISH <input checked="" type="checkbox"/> UNLESS OTHERWISE SPECIFIED		UNLESS OTHERWISE SPECIFIED DIMENSIONS ARE IN INCHES		APPROVALS		DATE		 ELECTRO MECHANICAL INDUSTRIES, INC. 11230 NEESEHAW DRIVE HOUSTON, TEXAS 77065 1-800-453-0050	
MATERIAL SEE PARTS LIST		TOLERANCES		DRAWN RLWjr		1/13/2023			
THIRD ANGLE PROJECTION 		.0 ±.06 .00 ±.015 .000 ±.005		CHECKER F. MERCHAN		1/13/2023		TITLE: 10"DIA X 10' DIRECT BURIAL FOUNDATION	
NEXT ASSY		FRACTIONS ± 1/16 ANGLES ± .25°		ENGINEER F. MERCHAN		1/13/2023			
USED ON		HOLES: DRILLED OR PUNCHED ± 1/32		PRODUCTION J. KERNER		1/13/2023			
APPLICATIONS		BURNED ± 1/32						SIZE B DRAWING NO. 1008-0000-0036 REV 1 SCALE: 1:16 WEIGHT: 353.0 lbs. SHEET 1 OF 1	