

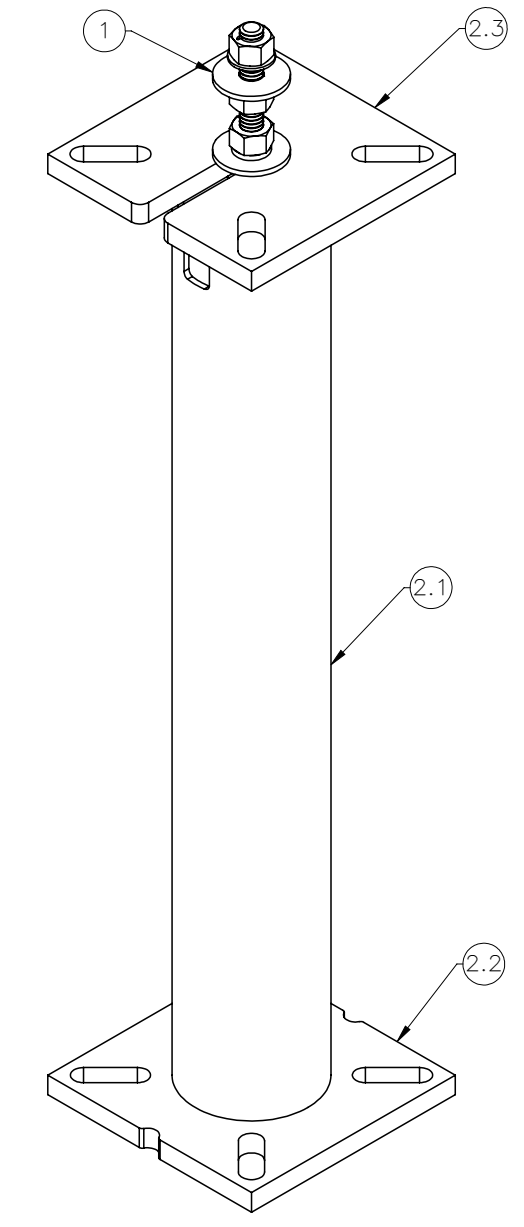

THE INFORMATION CONTAINED IN THIS DRAWING IS THE SOLE PROPERTY OF ELECTRO MECHANICAL INDUSTRIES, INC. ANY REPRODUCTION IN PART OR WHOLE WITHOUT THE WRITTEN PERMISSION OF ELECTRO MECHANICAL IND., IS PROHIBITED.

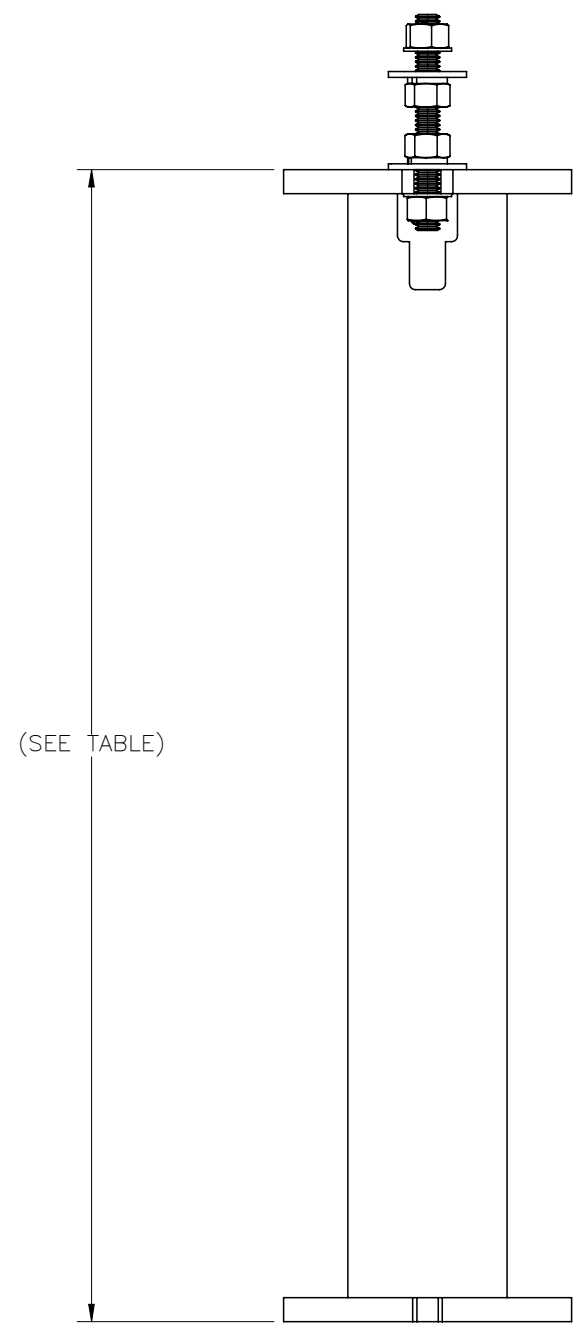

ITEM NO.	QTY REQD	PART NUMBER	DESCRIPTION	LENGTH	WEIGHT
1	1	1000-0020-0076	SINGLE MOUNT LEVELING HARDWARE KIT		5
2	1	1008-T006-0000-W	6" EXTENSION WELDMENT	SEE TABLE	SEE TABLE
2.1	1	1008-T006-0000_1	HSS 6.625 X 0.280, ASTM A500, 42 KSI MIN. YIELD	SEE TABLE	SEE TABLE
2.2	1	P-000-979	TOP PLATE	12"	30.1
2.3	1	P-001-997	TOP PLATE	12"	34.7

SURFACE FINISH <input checked="" type="checkbox"/> UNLESS OTHERWISE SPECIFIED		UNLESS OTHERWISE SPECIFIED DIMENSIONS ARE IN INCHES		APPROVALS	DATE	 ELECTRO MECHANICAL INDUSTRIES, INC. 11230 NEESESHAW DRIVE HOUSTON, TEXAS 77065 1-800-453-0050
MATERIAL	SEE PARTS LIST	TOLERANCES		DRAWN	1/9/2023	
THIRD ANGLE PROJECTION		.0 ± .06 .00 ± .015 .000 ± .005		CHECKER	1/19/2023	TITLE: <b>6" EXTENSION TABLE          DRAWING, SINGLE POINT</b>
		FRACTIONS ± 1/16 ANGLES ± .25°		ENGINEER	1/19/2023	
NEXT ASSY	USED ON	HOLES: DRILLED OR PUNCHED ± 1/32 BURNED ± 1/32		PRODUCTION	1/19/2023	
APPLICATIONS				J. KERNER		SIZE <b>B</b> DRAWING NO. <b>1008-T006-0000</b> REV <b>0</b> SCALE: 1:8 WEIGHT: 141.68 lbs. SHEET 1 OF 2

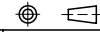
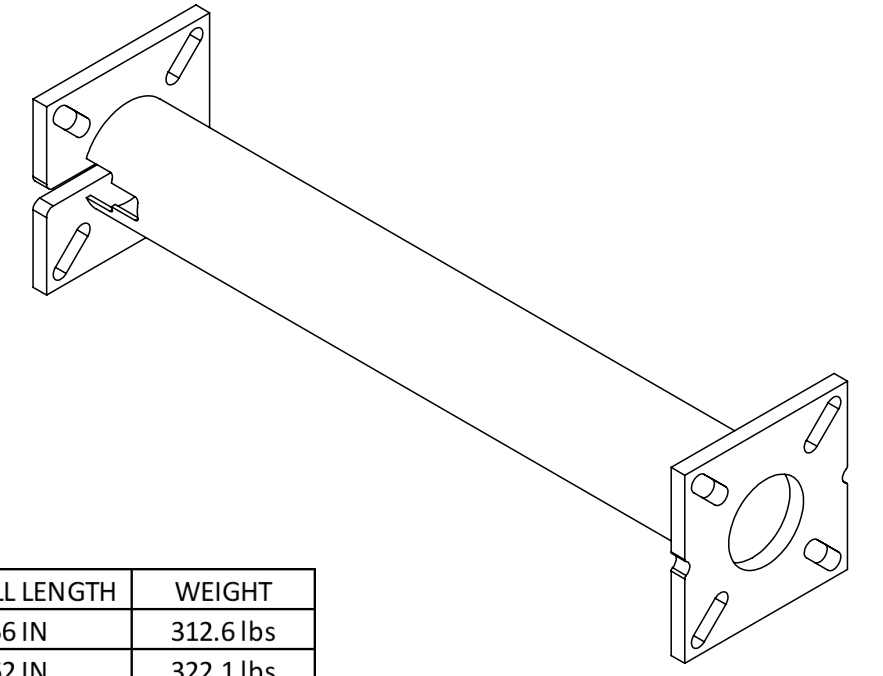
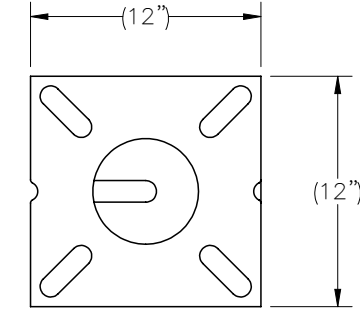
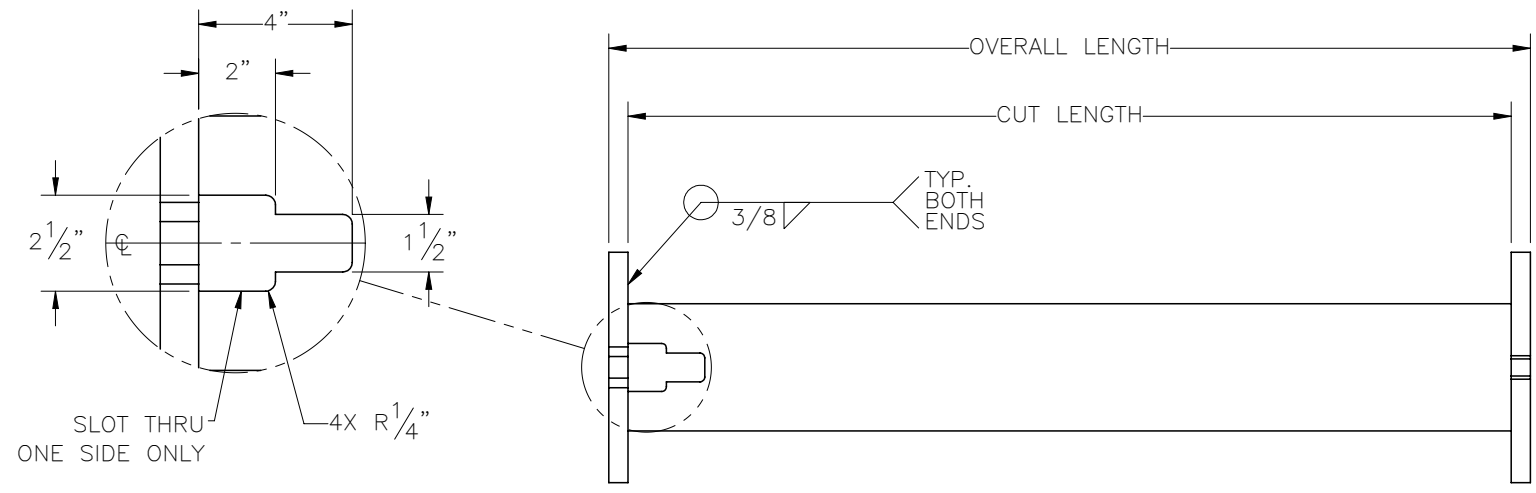

PART #	DESCRIPTION	CUT LENGTH	OVERALL LENGTH	WEIGHT
1008-T006-0080	0.7 FT EXTENSION	6 IN	8 IN	78.4 lbs
1008-T006-0120	1.0 FT EXTENSION	10 IN	12 IN	84.7 lbs
1008-T006-0180	1.5 FT EXTENSION	16 IN	18 IN	94.2 lbs
1008-T006-0240	2.0 FT EXTENSION	22 IN	24 IN	103.7 lbs
1008-T006-0300	2.5 FT EXTENSION	28 IN	30 IN	113.2 lbs
1008-T006-0360	3.0 FT EXTENSION	34 IN	36 IN	122.7 lbs
1008-T006-0420	3.5 FT EXTENSION	40 IN	42 IN	132.2 lbs
1008-T006-0480	4.0 FT EXTENSION	46 IN	48 IN	141.7 lbs
1008-T006-0540	4.5 FT EXTENSION	52 IN	54 IN	151.2 lbs
1008-T006-0600	5.0 FT EXTENSION	58 IN	60 IN	160.7 lbs
1008-T006-0660	5.5 FT EXTENSION	64 IN	66 IN	170.2 lbs
1008-T006-0720	6.0 FT EXTENSION	70 IN	72 IN	179.7 lbs
1008-T006-0780	6.5 FT EXTENSION	76 IN	78 IN	189.2 lbs
1008-T006-0840	7.0 FT EXTENSION	82 IN	84 IN	198.7 lbs
1008-T006-0900	7.5 FT EXTENSION	88 IN	90 IN	208.2 lbs
1008-T006-0960	8.0 FT EXTENSION	94 IN	96 IN	217.7 lbs
1008-T006-1020	8.5 FT EXTENSION	100 IN	102 IN	227.1 lbs
1008-T006-1080	9.0 FT EXTENSION	106 IN	108 IN	236.6 lbs
1008-T006-1140	9.5 FT EXTENSION	112 IN	114 IN	246.1 lbs
1008-T006-1200	10.0 FT EXTENSION	118 IN	120 IN	255.6 lbs
1008-T006-1260	10.5 FT EXTENSION	124 IN	126 IN	265.1 lbs
1008-T006-1320	11.0 FT EXTENSION	130 IN	132 IN	274.6 lbs
1008-T006-1380	11.5 FT EXTENSION	136 IN	138 IN	284.1 lbs
1008-T006-1440	12.0 FT EXTENSION	142 IN	144 IN	293.6 lbs
1008-T006-1500	12.5 FT EXTENSION	148 IN	150 IN	303.1 lbs

PART #	DESCRIPTION	CUT LENGTH	OVERALL LENGTH	WEIGHT
1008-T006-1560	13.0 FT EXTENSION	154 IN	156 IN	312.6 lbs
1008-T006-1620	13.5 FT EXTENSION	160 IN	162 IN	322.1 lbs
1008-T006-1680	14.0 FT EXTENSION	166 IN	168 IN	331.6 lbs
1008-T006-1740	14.5 FT EXTENSION	172 IN	174 IN	341.1 lbs
1008-T006-1800	15.0 FT EXTENSION	178 IN	180 IN	350.6 lbs
1008-T006-1860	15.5 FT EXTENSION	184 IN	186 IN	360.1 lbs
1008-T006-1920	16.0 FT EXTENSION	190 IN	192 IN	369.6 lbs
1008-T006-1980	16.5 FT EXTENSION	196 IN	198 IN	379.1 lbs
1008-T006-2040	17.0 FT EXTENSION	202 IN	204 IN	388.6 lbs
1008-T006-2100	17.5 FT EXTENSION	208 IN	210 IN	398.1 lbs
1008-T006-2160	18.0 FT EXTENSION	214 IN	216 IN	407.6 lbs
1008-T006-2220	18.5 FT EXTENSION	220 IN	222 IN	417.1 lbs
1008-T006-2280	19.0 FT EXTENSION	226 IN	228 IN	426.6 lbs
1008-T006-2340	19.5 FT EXTENSION	232 IN	234 IN	436.1 lbs
1008-T006-2400	20.0 FT EXTENSION	238 IN	240 IN	445.6 lbs
1008-T006-2460	20.5 FT EXTENSION	244 IN	246 IN	455.1 lbs
1008-T006-2520	21.0 FT EXTENSION	250 IN	252 IN	464.5 lbs
1008-T006-2580	21.5 FT EXTENSION	256 IN	258 IN	474.0 lbs
1008-T006-2640	22.0 FT EXTENSION	262 IN	264 IN	483.5 lbs
1008-T006-2700	22.5 FT EXTENSION	268 IN	270 IN	493.0 lbs
1008-T006-2760	23.0 FT EXTENSION	274 IN	276 IN	502.5 lbs
1008-T006-2820	23.5 FT EXTENSION	280 IN	282 IN	512.0 lbs
1008-T006-2880	24.0 FT EXTENSION	286 IN	288 IN	521.5 lbs
1008-T006-2940	24.5 FT EXTENSION	292 IN	294 IN	531.0 lbs
1008-T006-3000	25.0 FT EXTENSION	298 IN	300 IN	540.5 lbs

- NOTES:  
UNLESS OTHERWISE SPECIFIED,
1. ALL WELDING PER AWS D1.1, FCAW, E7XT-1 AND GMAW, ER70S-6 ELECTRODES.
  2. SQUARENESS OF WELDED COMPONENTS TO BE WITHIN +/- 1/16".
  3. ALL WELDS 3/16" FILLET OR SEAM WELDS ALL AROUND AS APPLICABLE PER JOINT.
  4. ALL CAPTIVE TUBES MUST HAVE MIN. TWO WEEP HOLES (ONE UPPER, ONE LOWER) 7/16" DIA.
  5. GALVANIZE PER ASTM A123.

EMI  
ELECTRO MECHANICAL INDUSTRIES, INC.  
11230 NEESHAW DRIVE  
HOUSTON, TEXAS 77065  
1-800-453-0050

SIZE	DRAWING NO.	REV.
B	1008-T006-0000	0
SCALE: 1:12	SHEET 2 OF 2	