

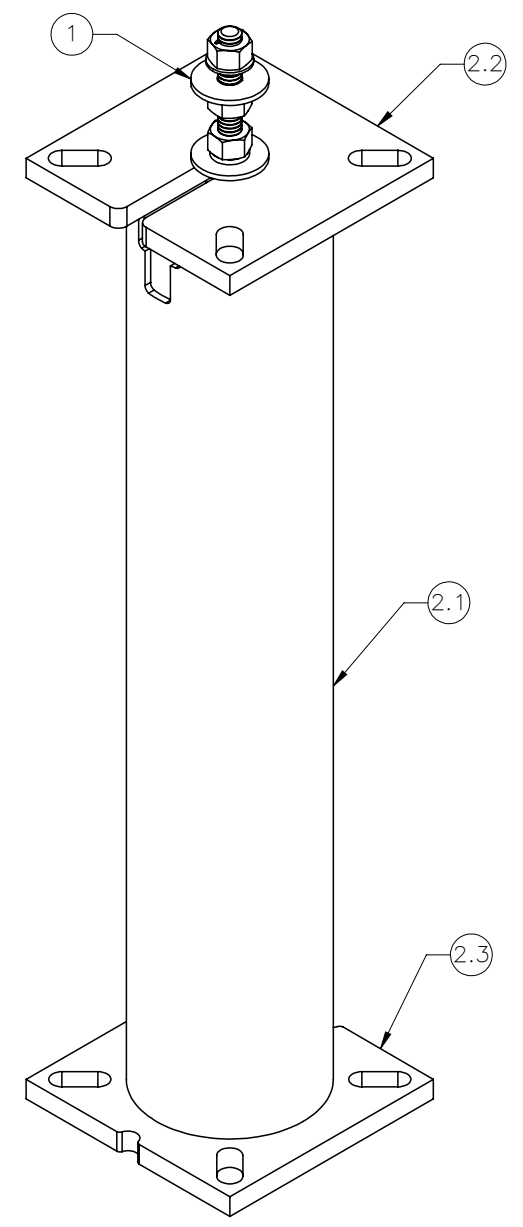

THE INFORMATION CONTAINED IN THIS DRAWING IS THE SOLE PROPERTY OF ELECTRO MECHANICAL INDUSTRIES, INC. ANY REPRODUCTION IN PART OR WHOLE WITHOUT THE WRITTEN PERMISSION OF ELECTRO MECHANICAL IND., IS PROHIBITED.

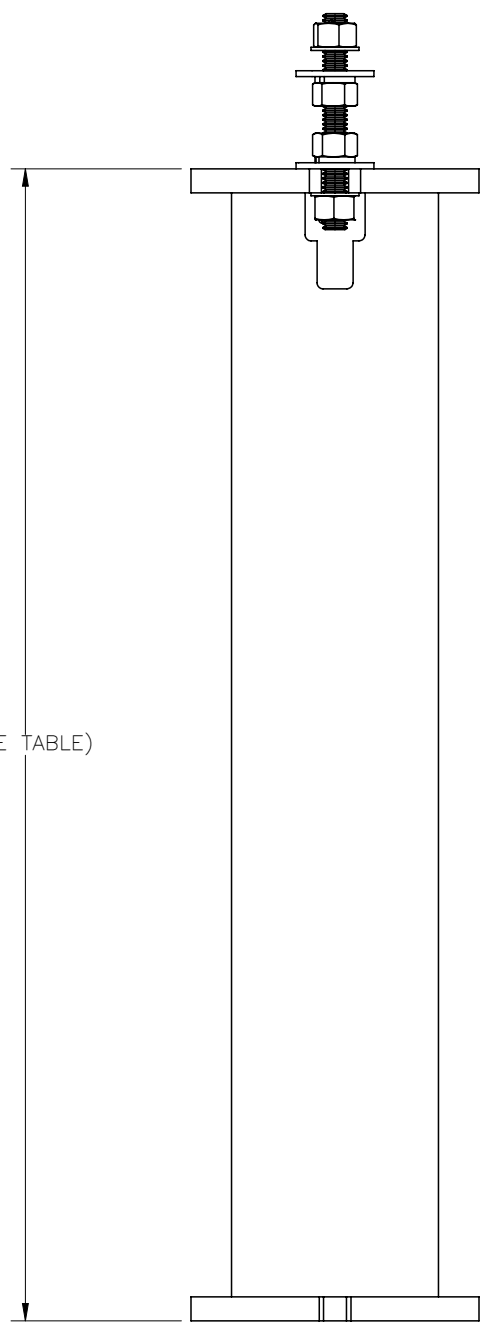

ITEM NO.	QTY REQD	PART NUMBER	DESCRIPTION	LENGTH	WEIGHT
1	1	1000-0020-0076	SINGLE MOUNT LEVELING HARDWARE KIT		5
2	1	1008-T008-0000-W	8" EXTENSION WELDMENT, SINGLE POINT	SEE TABLE	SEE TABLE
2.1	1	1008-T008-0000_1	PIPE, 8.00 INCH, SCH. 40, ASTM A500 GR. B STL.	SEE TABLE	SEE TABLE
2.2	1	P-006-615	TOP PLATE	12"	35.7
2.3	1	P-001-058	TOP PLATE	12"	25.08

SURFACE FINISH <input checked="" type="checkbox"/> UNLESS OTHERWISE SPECIFIED		UNLESS OTHERWISE SPECIFIED DIMENSIONS ARE IN INCHES		APPROVALS	DATE	 ELECTRO MECHANICAL INDUSTRIES, INC. 11230 NEESESHAW DRIVE HOUSTON, TEXAS 77065 1-800-453-0050
MATERIAL SEE PARTS LIST		TOLERANCES .0 ± .06 .00 ± .015 .000 ± .005 FRACTIONS ± 1/16 ANGLES ± .25° HOLES: DRILLED OR PUNCHED ± 1/32 BURNED ± 1/32		DRAWN J. ROACH	1/19/2023	
THIRD ANGLE PROJECTION 				CHECKER J. Breen	1/19/2023	TITLE: <b>8" EXTENSION TABLE          DRAWING, SINGLE POINT</b>
NEXT ASSY		USED ON		ENGINEER J. Breen	1/19/2023	
APPLICATIONS				PRODUCTION J. KERNER	1/19/2023	SIZE <b>B</b> DRAWING NO. <b>1008-T008-0000</b> SCALE: 1:8 WEIGHT: 174.29 lbs. SHEET 1 OF 2

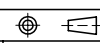
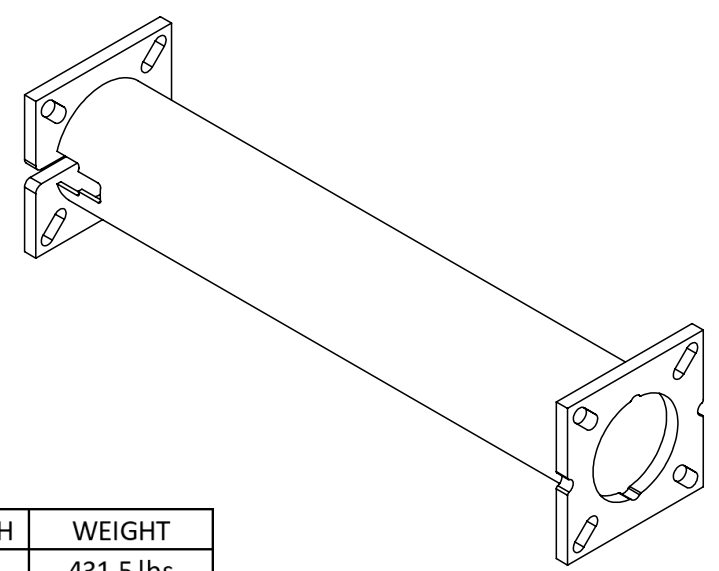
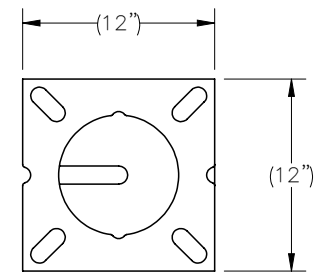
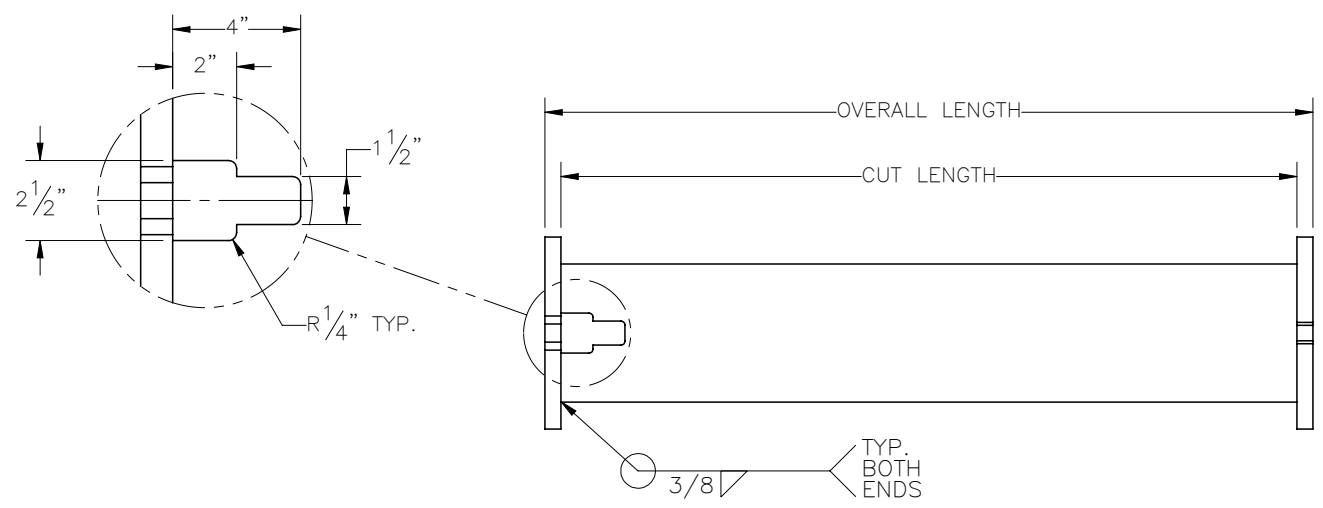

PART #	DESCRIPTION	CUT LENGTH	OVERALL LENGTH	WEIGHT
1008-T008-0080	0.7 FT EXTENSION	6 IN	8 IN	79.0 lbs
1008-T008-0120	1.0 FT EXTENSION	10 IN	12 IN	88.6 lbs
1008-T008-0180	1.5 FT EXTENSION	16 IN	18 IN	102.8 lbs
1008-T008-0240	2.0 FT EXTENSION	22 IN	24 IN	117.1 lbs
1008-T008-0300	2.5 FT EXTENSION	28 IN	30 IN	131.4 lbs
1008-T008-0360	3.0 FT EXTENSION	34 IN	36 IN	145.7 lbs
1008-T008-0420	3.5 FT EXTENSION	40 IN	42 IN	160.0 lbs
1008-T008-0480	4.0 FT EXTENSION	46 IN	48 IN	174.3 lbs
1008-T008-0540	4.5 FT EXTENSION	52 IN	54 IN	188.6 lbs
1008-T008-0600	5.0 FT EXTENSION	58 IN	60 IN	202.9 lbs
1008-T008-0660	5.5 FT EXTENSION	64 IN	66 IN	217.2 lbs
1008-T008-0720	6.0 FT EXTENSION	70 IN	72 IN	231.5 lbs
1008-T008-0780	6.5 FT EXTENSION	76 IN	78 IN	245.7 lbs
1008-T008-0840	7.0 FT EXTENSION	82 IN	84 IN	260.0 lbs
1008-T008-0900	7.5 FT EXTENSION	88 IN	90 IN	274.3 lbs
1008-T008-0960	8.0 FT EXTENSION	94 IN	96 IN	288.6 lbs
1008-T008-1020	8.5 FT EXTENSION	100 IN	102 IN	302.9 lbs
1008-T008-1080	9.0 FT EXTENSION	106 IN	108 IN	317.2 lbs
1008-T008-1140	9.5 FT EXTENSION	112 IN	114 IN	331.5 lbs
1008-T008-1200	10.0 FT EXTENSION	118 IN	120 IN	345.8 lbs
1008-T008-1260	10.5 FT EXTENSION	124 IN	126 IN	360.1 lbs
1008-T008-1320	11.0 FT EXTENSION	130 IN	132 IN	374.4 lbs
1008-T008-1380	11.5 FT EXTENSION	136 IN	138 IN	388.7 lbs
1008-T008-1440	12.0 FT EXTENSION	142 IN	144 IN	402.9 lbs
1008-T008-1500	12.5 FT EXTENSION	148 IN	150 IN	417.2 lbs

PART #	DESCRIPTION	CUT LENGTH	OVERALL LENGTH	WEIGHT
1008-T008-1560	13.0 FT EXTENSION	154 IN	156 IN	431.5 lbs
1008-T008-1620	13.5 FT EXTENSION	160 IN	162 IN	445.8 lbs
1008-T008-1680	14.0 FT EXTENSION	166 IN	168 IN	460.1 lbs
1008-T008-1740	14.5 FT EXTENSION	172 IN	174 IN	474.4 lbs
1008-T008-1800	15.0 FT EXTENSION	178 IN	180 IN	488.7 lbs
1008-T008-1860	15.5 FT EXTENSION	184 IN	186 IN	503.0 lbs
1008-T008-1920	16.0 FT EXTENSION	190 IN	192 IN	517.3 lbs
1008-T008-1980	16.5 FT EXTENSION	196 IN	198 IN	531.6 lbs
1008-T008-2040	17.0 FT EXTENSION	202 IN	204 IN	545.8 lbs
1008-T008-2100	17.5 FT EXTENSION	208 IN	210 IN	560.1 lbs
1008-T008-2160	18.0 FT EXTENSION	214 IN	216 IN	574.4 lbs
1008-T008-2220	18.5 FT EXTENSION	220 IN	222 IN	588.7 lbs
1008-T008-2280	19.0 FT EXTENSION	226 IN	228 IN	603.0 lbs
1008-T008-2340	19.5 FT EXTENSION	232 IN	234 IN	617.3 lbs
1008-T008-2400	20.0 FT EXTENSION	238 IN	240 IN	631.6 lbs
1008-T008-2460	20.5 FT EXTENSION	244 IN	246 IN	645.9 lbs
1008-T008-2520	21.0 FT EXTENSION	250 IN	252 IN	660.2 lbs
1008-T008-2580	21.5 FT EXTENSION	256 IN	258 IN	674.5 lbs
1008-T008-2640	22.0 FT EXTENSION	262 IN	264 IN	688.8 lbs
1008-T008-2700	22.5 FT EXTENSION	268 IN	270 IN	703.0 lbs
1008-T008-2760	23.0 FT EXTENSION	274 IN	276 IN	717.3 lbs
1008-T008-2820	23.5 FT EXTENSION	280 IN	282 IN	731.6 lbs
1008-T008-2880	24.0 FT EXTENSION	286 IN	288 IN	745.9 lbs
1008-T008-2940	24.5 FT EXTENSION	292 IN	294 IN	760.2 lbs
1008-T008-3000	25.0 FT EXTENSION	298 IN	300 IN	774.5 lbs

- NOTES:  
UNLESS OTHERWISE SPECIFIED,
1. ALL WELDING PER AWS D1.1, FCAW, E7XT-1 AND GMAW, ER70S-6 ELECTRODES.
  2. SQUARENESS OF WELDED COMPONENTS TO BE WITHIN +/- 1/16".
  3. ALL WELDS 3/16" FILLET OR SEAM WELDS ALL AROUND AS APPLICABLE PER JOINT.
  4. ALL CAPTIVE TUBES MUST HAVE MIN. TWO WEEP HOLES (ONE UPPER, ONE LOWER) 7/16" DIA.
  5. GALVANIZE PER ASTM A123.

**EMI** ELECTRO MECHANICAL INDUSTRIES, INC.  
11230 NEESHAW DRIVE  
HOUSTON, TEXAS 77065  
1-800-453-0050

SIZE	DRAWING NO.	REV.
B	1008-T008-0000	0
SCALE: 1:12	SHEET 2 OF 2	