

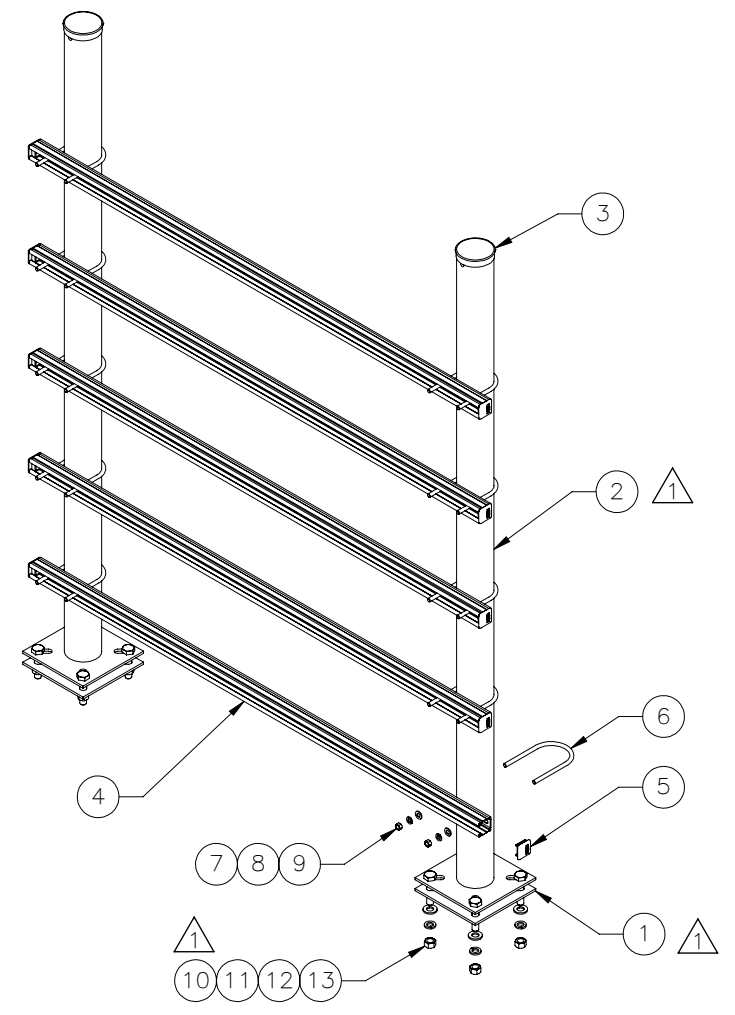

THE INFORMATION CONTAINED IN THIS DRAWING IS THE SOLE PROPERTY OF ELECTRO MECHANICAL INDUSTRIES, INC. ANY REPRODUCTION IN PART OR WHOLE WITHOUT THE WRITTEN PERMISSION OF ELECTRO MECHANICAL IND., IS PROHIBITED.

REVISIONS					
REV.	DCN #	DESCRIPTION	DATE	BY	APPROVED
1	01222	72-7/8" WAS 73-1/8", 002-0BG-0276 WAS 002-0BG-0080, UPDATED WITH LOWER LEVEL CHANGES.	02/28/2022	JTR	JPB

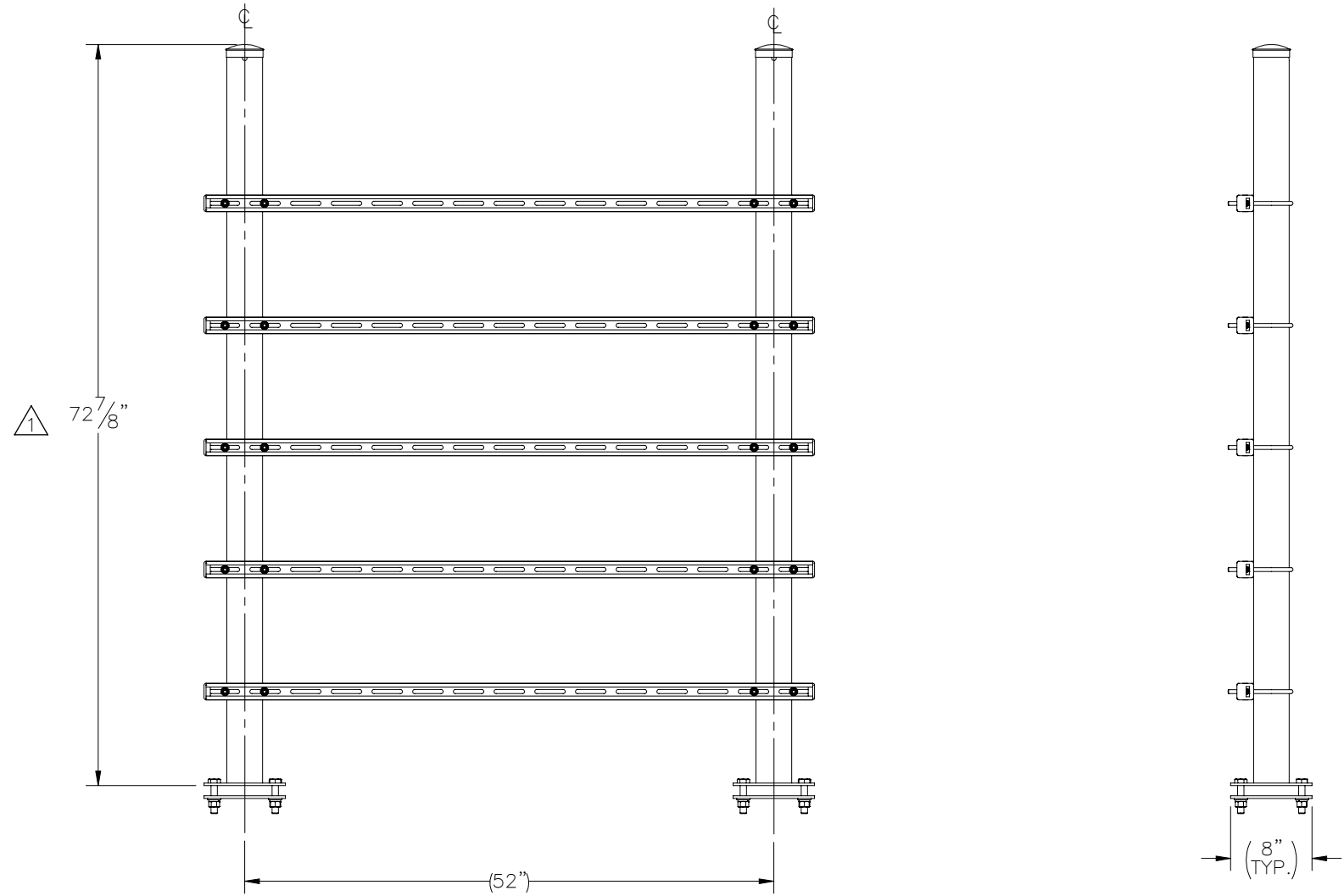
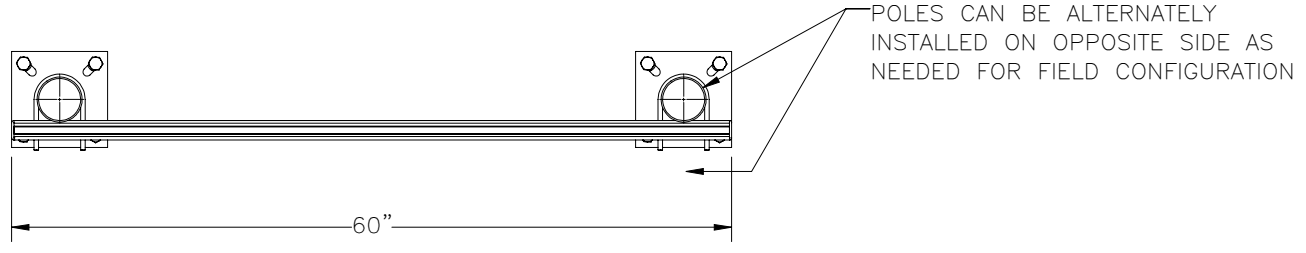

ITEM NO.	QTY REQD	PART NUMBER	DESCRIPTION	LENGTH	WEIGHT
1	2	P-006-469	PLATE, BASE		4.24
2	2	W-002-570	POST WELDMENT	72 1/2"	49.66
3	2	002-FPC-0001	CAP, POST, 3.5" OD, GALV STEEL		0.30
4	5	P-006-470	CROSSBAR, H-FRAME	59 5/8"	6.84
5	10	309-000-0004	COOPER B-LINE B825-22 END CAP		0.03
6	10	002-00U-G050	U-BOLT, .375-16 X 3.500 ID X 6.000 H X 2.50 TL, GALV	6"	0.46
7	20	002-0FW-G005	WASHER, FLAT, .375, GALV, SAE		0.01
8	20	002-0LW-G005	WASHER, SPLIT LOCK, .375, GALV		0.01
9	20	002-0NG-0003	NUT, HEX, .375-16, GALV, GR 2H		0.015
10	8	002-0BG-0276	BOLT, HH, .625-11 X 3.00, GALV, A325, PT X 1.25	3"	0.3687
11	8	002-0FW-G004	WASHER, FLAT, .625, GALV, F436		0.04
12	8	002-0LW-G004	WASHER, SPLIT LOCK, .625, GALV		0.03
13	8	002-0NG-0004	NUT, HEX, .625-11, GALV, GR 2H		0.070

SURFACE FINISH <input checked="" type="checkbox"/> UNLESS OTHERWISE SPECIFIED		UNLESS OTHERWISE SPECIFIED DIMENSIONS ARE IN INCHES		APPROVALS		DATE		 ELECTRO MECHANICAL INDUSTRIES, INC. 11230 NEESESHAW DRIVE HOUSTON, TEXAS 77065 1-800-453-0050	
MATERIAL SEE PARTS LIST		TOLERANCES .0 ±.06 .00 ±.015 .000 ±.005 FRACTIONS ± 1/16 ANGLES ± .25° HOLES: DRILLED OR PUNCHED ± 1/32 BURNED ± 1/32		DRAWN J. ROACH 2/17/2023		2/17/2023			
THIRD ANGLE PROJECTION 				CHECKER J. Breen 2/17/2023				SIZE B DRAWING NO. 1010-0010-0174 REV 1	
NEXT ASSY		USED ON		ENGINEER J. Breen 2/17/2023		2/17/2023			
APPLICATIONS				PRODUCTION J. KERNER		2/17/2023			