

THE INFORMATION CONTAINED IN THIS DRAWING IS THE SOLE PROPERTY OF ELECTRO MECHANICAL INDUSTRIES, INC. ANY REPRODUCTION IN PART OR WHOLE WITHOUT THE WRITTEN PERMISSION OF ELECTRO MECHANICAL IND., IS PROHIBITED.

REVISIONS					
REV.	DCN #	DESCRIPTION	DATE	BY	APPROVED
1	01222	60-7/8" WAS 61-1/8", 002-0BG-0276 WAS 002-0BG-0080, UPDATED WITH LOWER LEVEL CHANGES.	02/28/2023	JTR	JPB

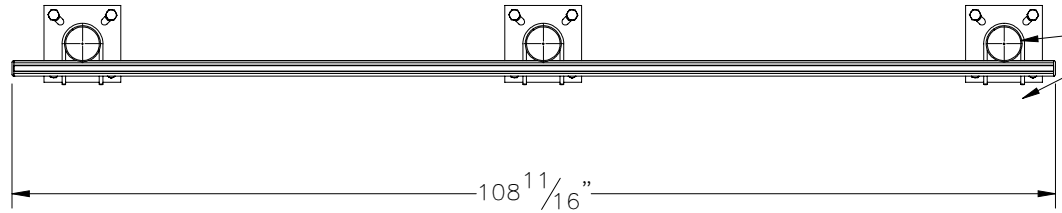

POLES CAN BE ALTERNATELY INSTALLED ON OPPOSITE SIDE AS NEEDED FOR FIELD CONFIGURATION

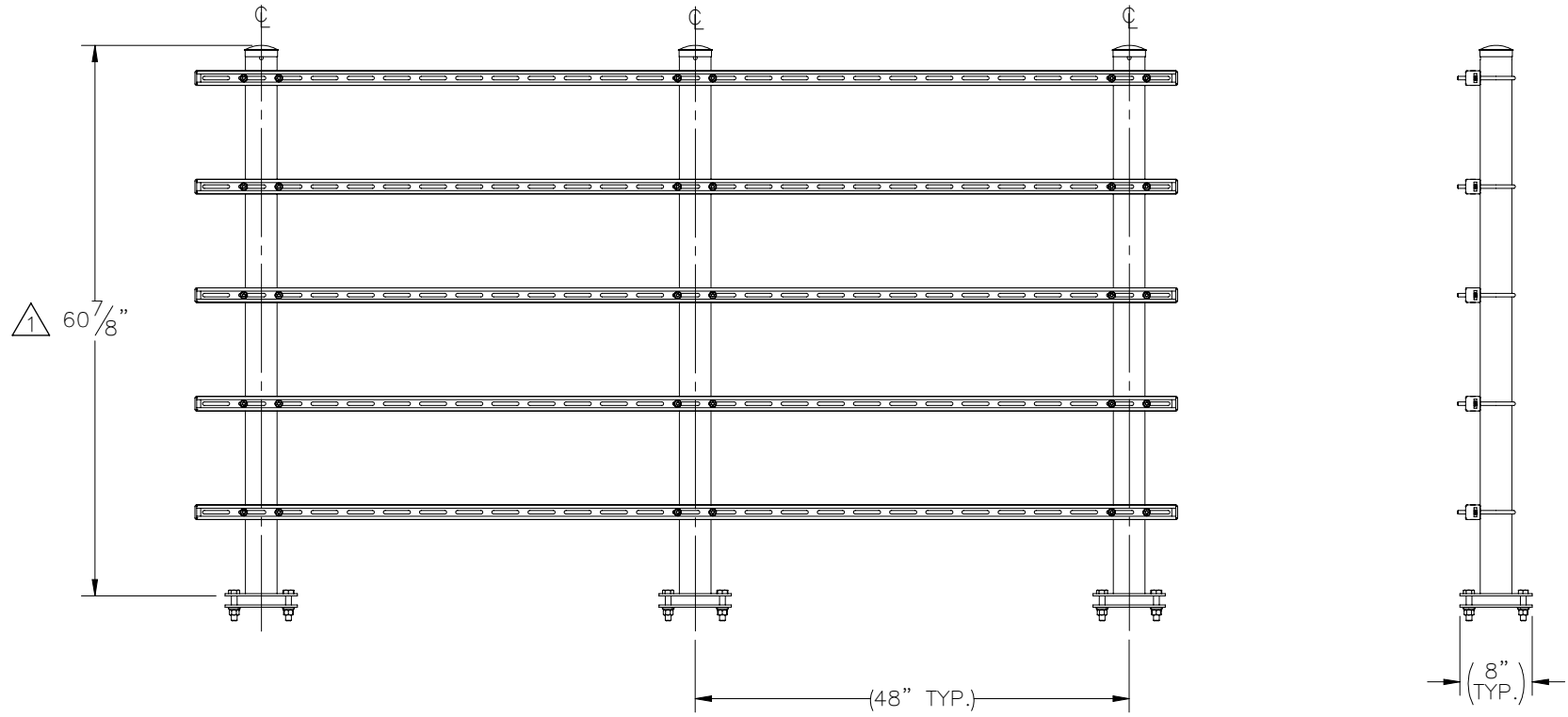
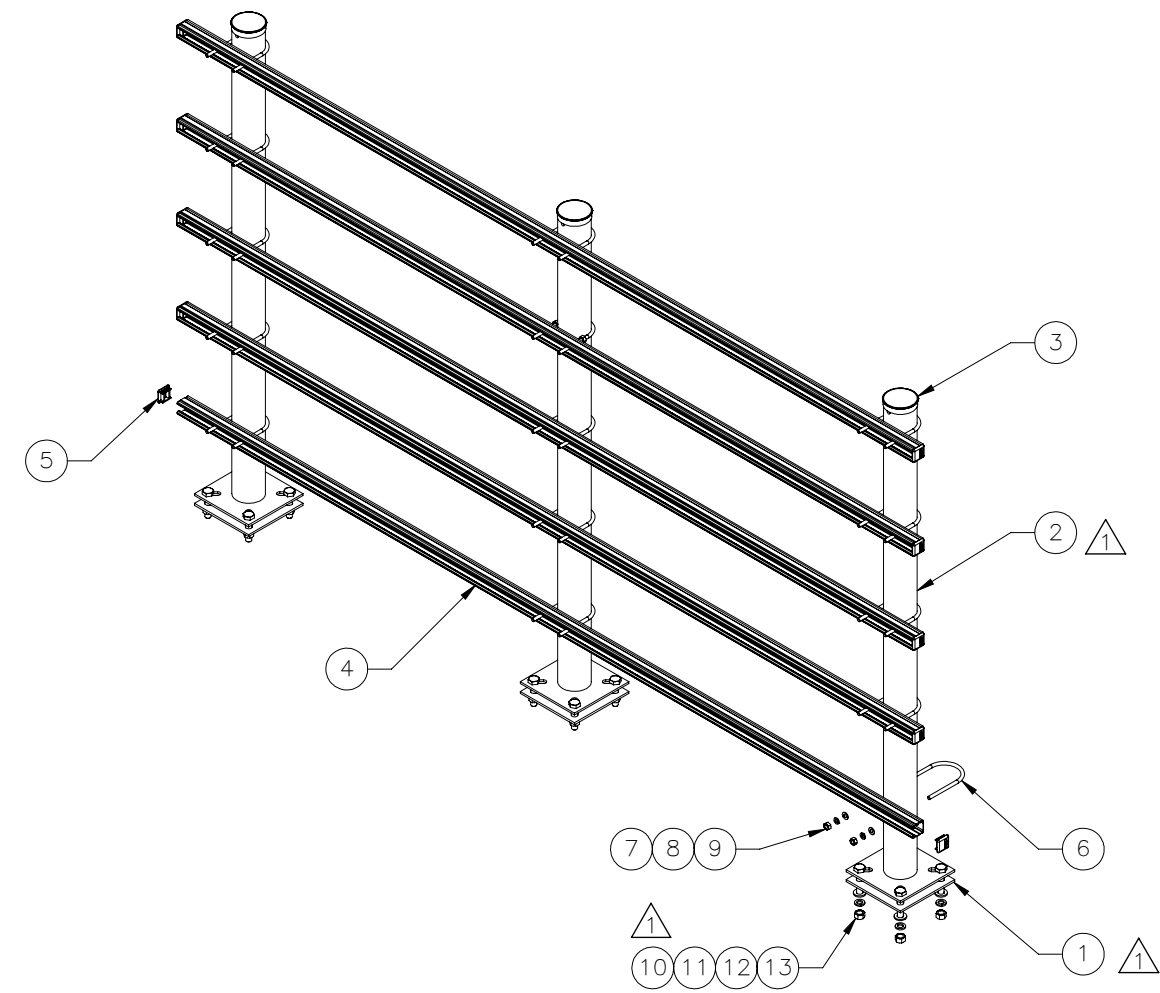

ITEM NO.	QTY REQD	PART NUMBER	DESCRIPTION	LENGTH	WEIGHT
1	3	P-006-469	PLATE, BASE		4.24
2	3	W-002-512	POST WELDMENT	60 1/2"	42.08
3	3	002-FPC-0001	CAP, POST, 3.5" OD, GALV STEEL		0.30
4	5	P-005-606	CROSSBAR, H-FRAME	108 5/16"	12.44
5	10	309-000-0004	COOPER B-LINE B825-22 END CAP		0.03
6	15	002-00U-G050	U-BOLT, .375-16 X 3.500 ID X 6.000 H X 2.50 TL, GALV	6"	0.46
7	30	002-0FW-G005	WASHER, FLAT, .375, GALV		0.01
8	30	002-0LW-G005	WASHER, SPLIT LOCK, .375, GALV		0.01
9	30	002-0NG-0003	NUT, HEX, .375-16UNC, GR 2H, GALV		0.03
10	12	002-0BG-0276	BOLT, HH, .625-11 X 3.00, GALV, A325, PT X 1.25	3 1/2"	0.3687
11	12	002-0FW-G004	WASHER, FLAT, .625, GALV, F436		0.04
12	12	002-0LW-G004	WASHER, SPLIT LOCK, .625, GALV		0.03
13	12	002-0NG-0004	NUT, HEX, .625-11, GALV, GR 2H		0.070

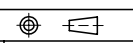
SURFACE FINISH <input checked="" type="checkbox"/> UNLESS OTHERWISE SPECIFIED		UNLESS OTHERWISE SPECIFIED DIMENSIONS ARE IN INCHES		APPROVALS		DATE		 ELECTRO MECHANICAL INDUSTRIES, INC. 1230 NEESESHAW DRIVE HOUSTON, TEXAS 77065 1-800-453-0050	
MATERIAL SEE PARTS LIST		TOLERANCES		DRAWN J. ROACH		2/14/2023			
THIRD ANGLE PROJECTION 		.0 ±.06 .00 ±.015 .000 ±.005		CHECKER J. Breen		2/16/2023		TITLE: H-FRAME, 5 LEVEL, 5' PIPE, 3 POST	
NEXT ASSY USED ON		FRACTIONS ± 1/16 ANGLES ± .25°		ENGINEER J. Breen		2/16/2023			
APPLICATIONS		HOLES: DRILLED OR PUNCHED ± 1/32 BURNED ± 1/32		PRODUCTION J. KERNER		2/16/2023		SIZE B DRAWING NO. 1010-0010-0188 REV 1 SCALE: 1:20 WEIGHT: 216.60 lbs. SHEET 1 OF 1	