

THE INFORMATION CONTAINED IN THIS DRAWING IS THE SOLE PROPERTY OF ELECTRO MECHANICAL INDUSTRIES, INC. ANY REPRODUCTION IN PART OR WHOLE WITHOUT THE WRITTEN PERMISSION OF ELECTRO MECHANICAL IND., IS PROHIBITED.

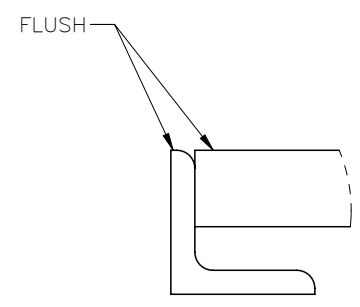
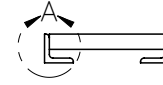
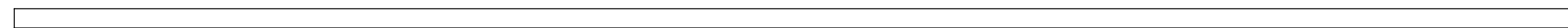
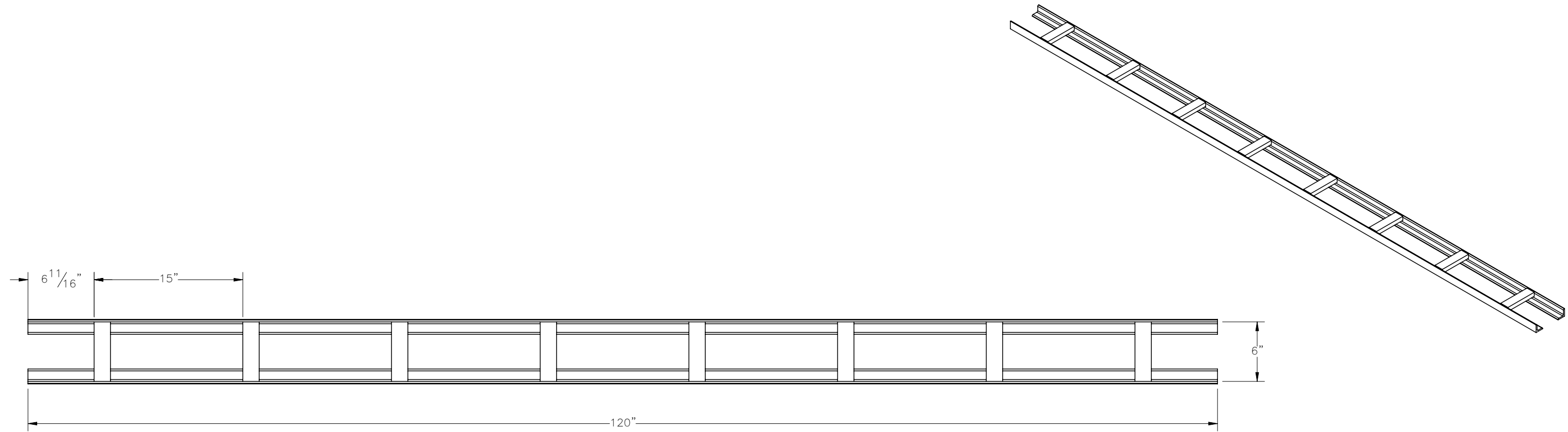

DETAIL A
SCALE 1:2

ITEM NO.	QTY	PART NUMBER	DESCRIPTION	LENGTH
1	2	115-T10-1506_1	ANGLE, 1 1/2"X1 1/2"X1/4" THK, ASTM A36 STL	120"
2	8	115-T10-1506_2	RUNG, CABLE TRAY, 304 SST	6"

SURFACE FINISH	UNLESS OTHERWISE SPECIFIED	UNLESS OTHERWISE SPECIFIED DIMENSIONS ARE IN INCHES	APPROVALS	DATE
MATERIAL	SEE PARTS LIST	TOLERANCES	DRAWN	6.30.15
THIRD ANGLE PROJECTION		.0	D. HUGHES	
		.00	CHECKED	
		.000	ENGINEER/DESIGNER	
		FRACTIONS	PRODUCTION	
		1/16		
		ANGLES		
		.25°		
NEXT ASSY	USED ON	HOLES: DRILLED OR PUNCHED		
		+1/32		
APPLICATIONS		BURNED		
		±1/32		

		ELECTRO MECHANICAL INDUSTRIES, INC. 11230 NEESHAW DRIVE HOUSTON, TEXAS 77065 1-800-453-0050	
TITLE:			
115 SERIES, 6" RUNG WIDTH			
SIZE	DRAWING NO.	REV	
B	115-T10-1506	-	
SCALE:	1:10	WEIGHT: 49.6 lbs.	SHEET 1 OF 1