

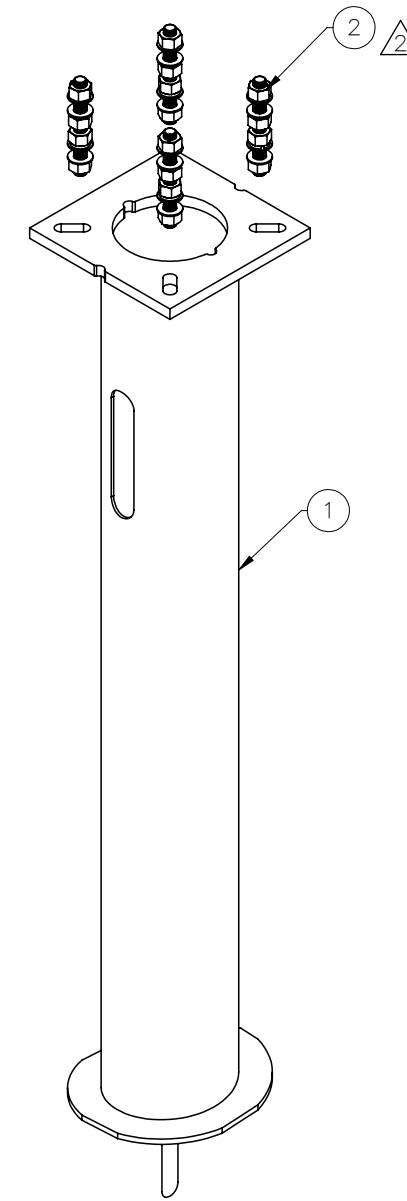

THE INFORMATION CONTAINED IN THIS DRAWING IS THE SOLE PROPERTY OF ELECTRO MECHANICAL INDUSTRIES, INC. ANY REPRODUCTION IN PART OR WHOLE WITHOUT THE WRITTEN PERMISSION OF ELECTRO MECHANICAL IND., IS PROHIBITED.

| REVISIONS |       |   |           |     |          |
|-----------|-------|---|-----------|-----|----------|
| REV.      | DCN # | DESCRIPTION   | DATE      | BY  | APPROVED |
| 2         | 01039 | REMOVED 002-OAT-H000, 002-ONG-0000, 002-ONG-0008, 002-OLW-G008, 002-0GW-G009 ADDED 1000-0020-0077 | 7/15/2021 | PCG | JPB      |

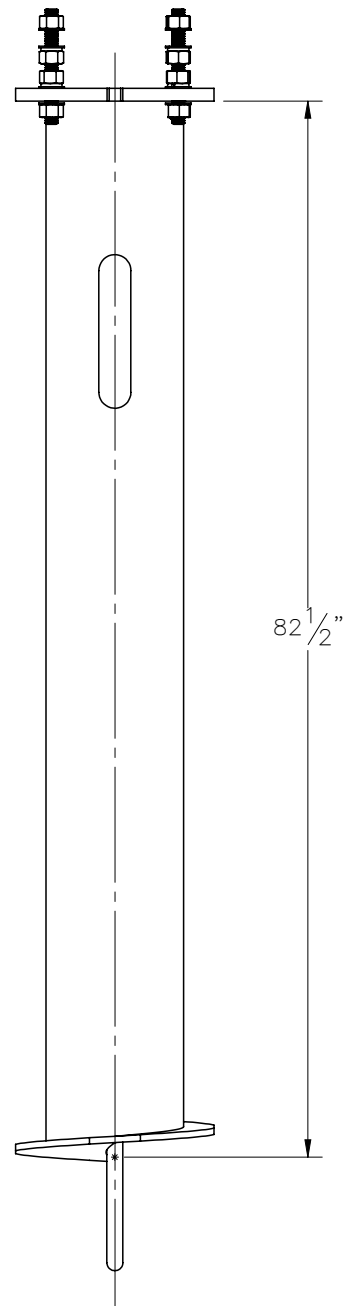
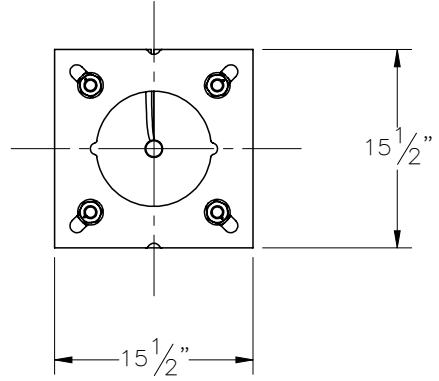

| ITEM NO. | QTY REQD | PART NUMBER    | DESCRIPTION                           | LENGTH | WEIGHT |
|----------|----------|----------------|---------------------------------------|--------|--------|
| 1        | 1        | 400-000-1007   | 10" x 7', 1" BASE, 1" HDW - HEL. PIER |        | 263    |
| 2        | 1        | 1000-0020-0077 | QUAD MOUNT LEVELING HARDWARE KIT      |        | 15.2   |

|  |  |   |  |               |  |               |  |  |  |
|--|--|---|--|---------------|--|---------------|--|--|--|
| SURFACE FINISH <input checked="" type="checkbox"/> UNLESS OTHERWISE SPECIFIED                                |  | UNLESS OTHERWISE SPECIFIED DIMENSIONS ARE IN INCHES |  | APPROVALS     |  | DATE          |  |  ELECTRO MECHANICAL INDUSTRIES, INC.<br>11230 NEESESHAW DRIVE<br>HOUSTON, TEXAS 77065<br>1-800-453-0050 |  |
| MATERIAL SEE PARTS LIST  |  | TOLERANCES  |  | DRAWN         |  | 5/16/2019     |  |  |  |
| THIRD ANGLE PROJECTION  |  | .0 ± .06  |  | CHECKER       |  | 5/24/2019     |  | TITLE:<br>10" x 7', 1" BASE, WITH<br>1" HDW - HEL. PIER  |  |
|  |  | .000 ± .005   |  | ENGINEER      |  | 5/30/2019     |  |  |  |
|  |  | FRACTIONS ± 1/16                                    |  | PRODUCTION    |  | 5/30/2021     |  |  |  |
|  |  | ANGLES ± .25°                                       |  | J. SUNDERLAND |  |               |  | SIZE B DRAWING NO. 400-000-1407 REV 2  |  |
| NEXT ASSY USED ON  |  | HOLES: DRILLED OR PUNCHED ± 1/32                    |  | APPLICATIONS  |  | BURNED ± 1/32 |  | SCALE: 1:15 WEIGHT: 278 lbs. SHEET 1 OF 1  |  |