

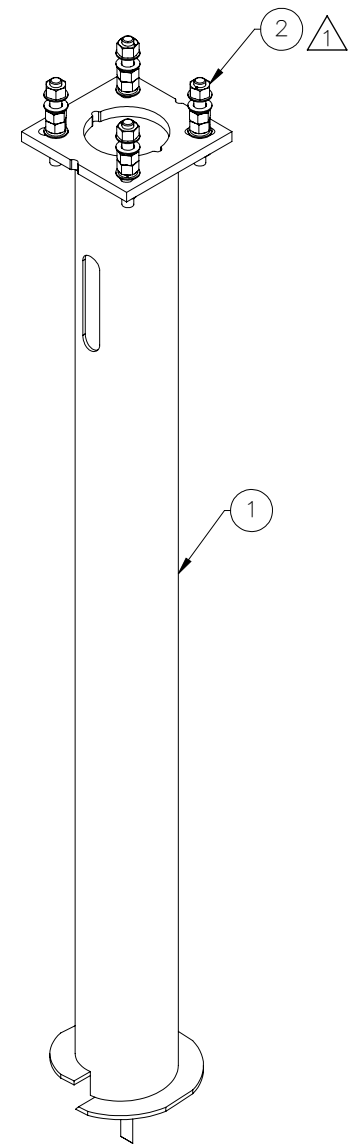

THE INFORMATION CONTAINED IN THIS DRAWING IS THE SOLE PROPERTY OF ELECTRO MECHANICAL INDUSTRIES, INC. ANY REPRODUCTION IN PART OR WHOLE WITHOUT THE WRITTEN PERMISSION OF ELECTRO MECHANICAL IND., IS PROHIBITED.

REVISIONS					
REV.	DCN #	DESCRIPTION	DATE	BY	APPROVED
1	01039	REMOVED 002-OAT-G001, 002-ONG-0020, 002-ONG-0022, 002-OLW-G001, 002-OFW-G011 ADDED 1000-0020-0078	6/30/2021	PCG	JPB

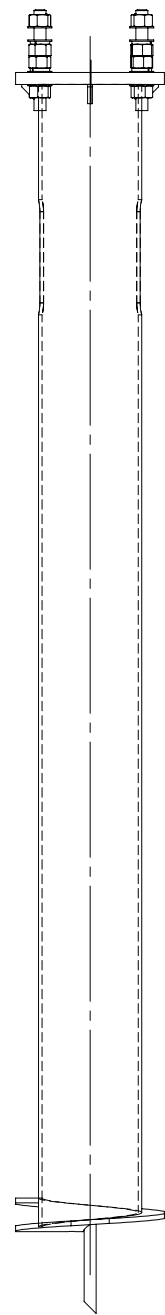
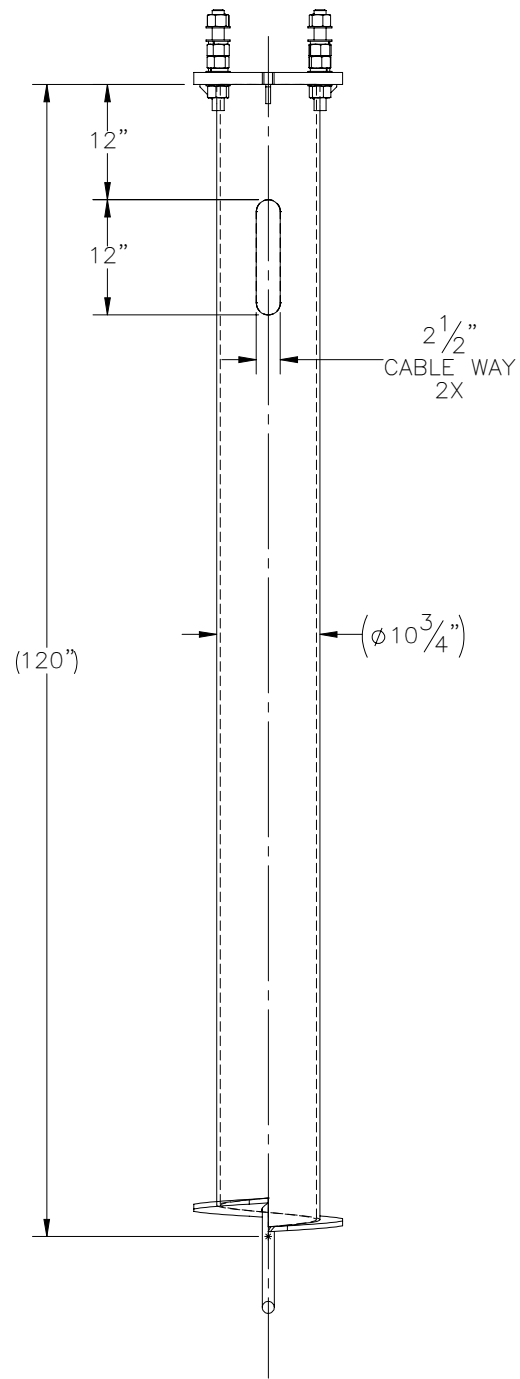
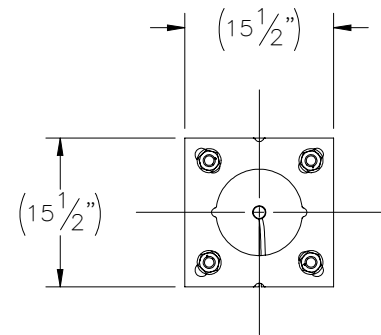

NOTES:
1. GALVANIZE PER ASTM A123

ITEM NO.	QTY REQD	PART NUMBER	DESCRIPTION	LENGTH	WEIGHT
1	1	400-000-1012	10" x 10', 1.25" BASE, 1.25" HDW - HEL. PIER GUSSETED		481
2	1	1000-0020-0078	QUAD 1.25" STUD LEVELING KIT		30.8

SURFACE FINISH	UNLESS OTHERWISE SPECIFIED	UNLESS OTHERWISE SPECIFIED DIMENSIONS ARE IN INCHES	APPROVALS	DATE	 ELECTRO MECHANICAL INDUSTRIES, INC. 11230 NEESEHAW DRIVE HOUSTON, TEXAS 77065 1-800-453-0050
MATERIAL	SEE PARTS LIST	TOLERANCES	DRAWN	6/3/2019	
THIRD ANGLE PROJECTION		.0 ± .06 .00 ± .015 .000 ± .005	CHECKER	6/3/2019	
		FRACTIONS ± 1/16 ANGLES ± .25°	ENGINEER	6/3/2019	
NEXT ASSY	USED ON	HOLES: DRILLED OR PUNCHED ± 1/32 BURNED ± 1/32	PRODUCTION	6/3/2019	

TITLE:		10" X 10' X 1.25" BASE PLATE W. HDW	
SIZE	DRAWING NO.	REV	
B	400-000-1412	1	
SCALE:	1:20	WEIGHT:	511.73 lbs.
		SHEET 1 OF 1	