

THE INFORMATION CONTAINED IN THIS DRAWING IS THE SOLE PROPERTY OF ELECTRO MECHANICAL INDUSTRIES, INC. ANY REPRODUCTION IN PART OR WHOLE WITHOUT THE WRITTEN PERMISSION OF ELECTRO MECHANICAL IND., IS PROHIBITED.

IF IN DOUBT...ASK!

REVISIONS					
REV	DCN #:	DESCRIPTION	DATE	BY	APPROVED

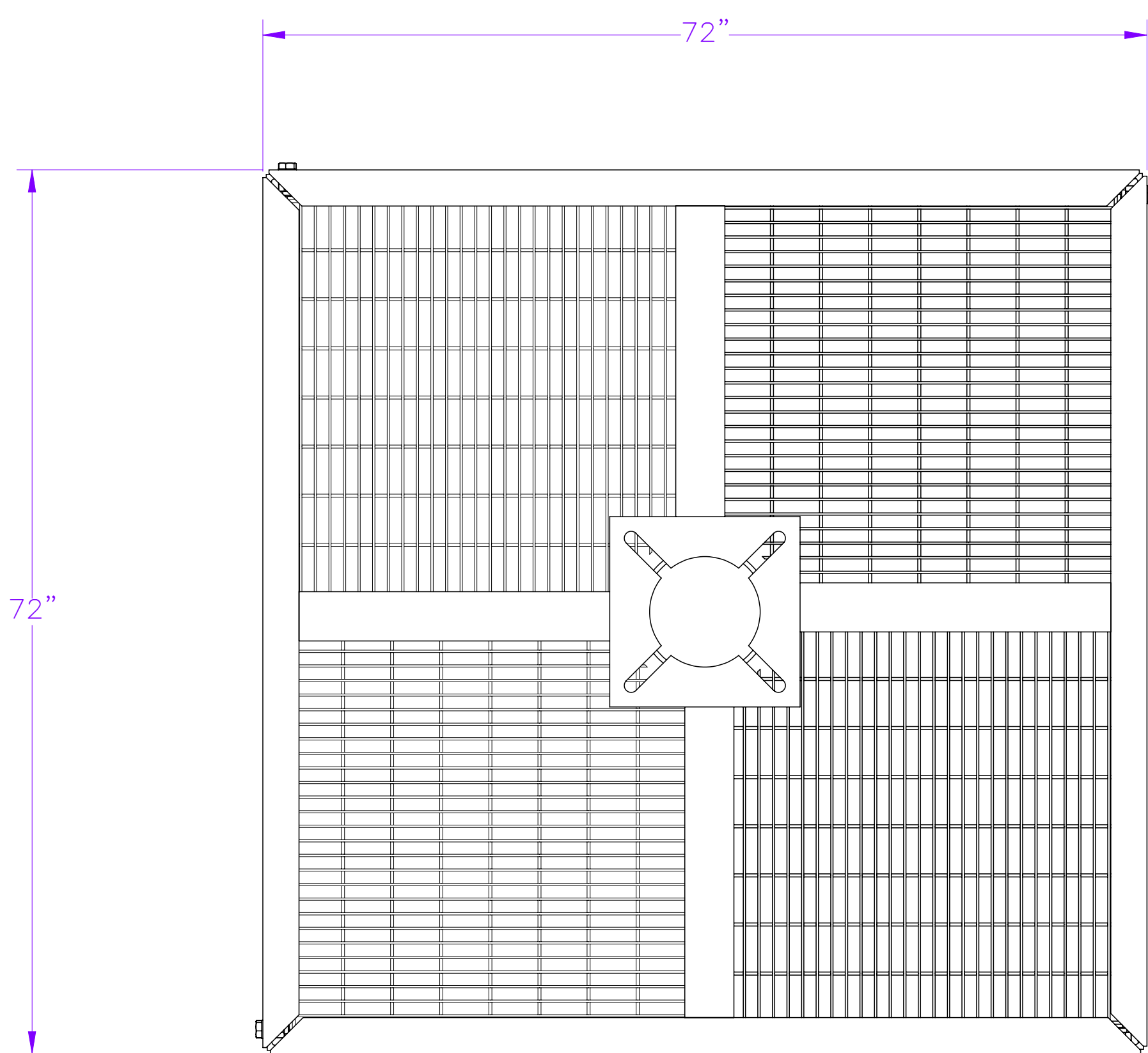

TOP VIEW  
(SHOWN WITH TOP GRATING REMOVED FOR CLARITY)

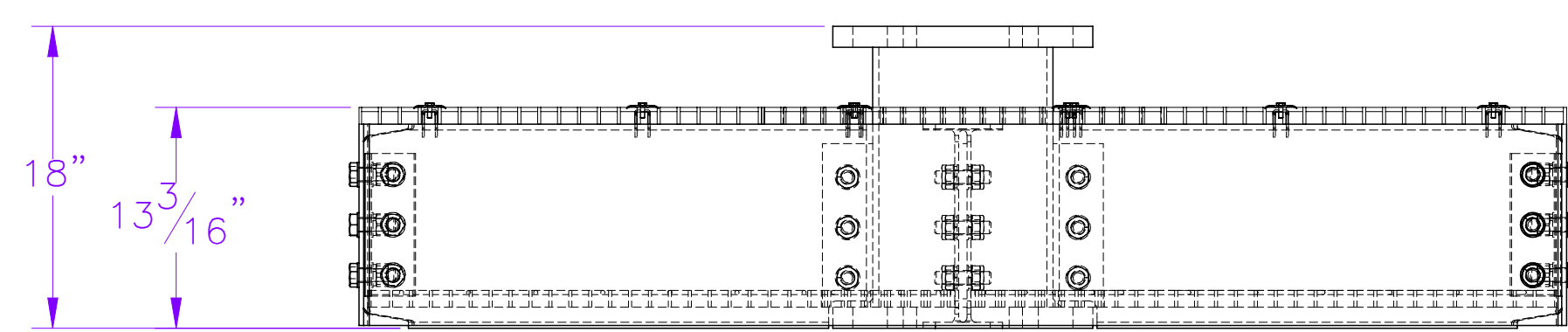
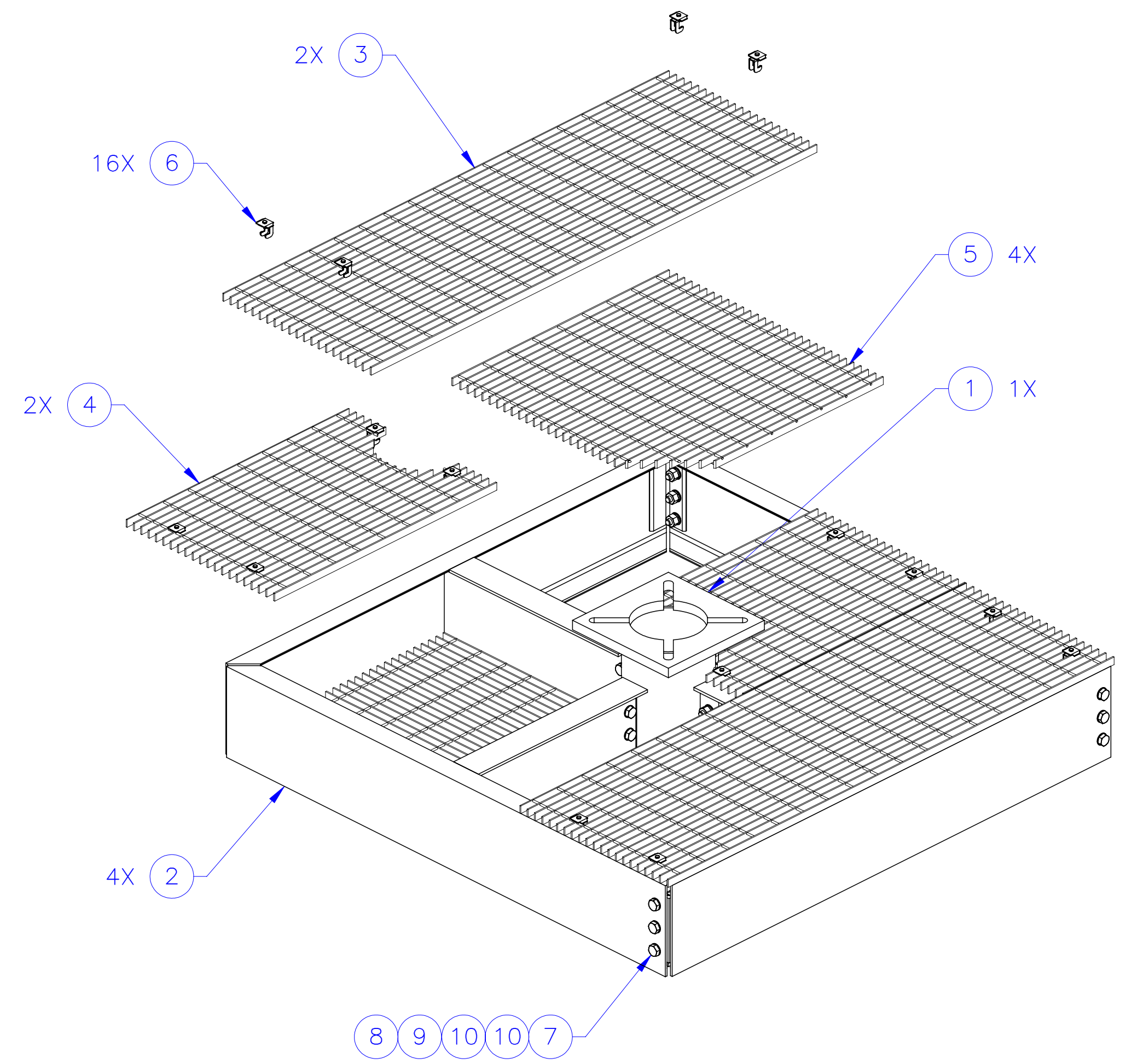

PARTS LIST					
ITEM NO.	QTY.	PART NUMBER	DESCRIPTION	LENGTH	WEIGHT
1	1	400-000-3531-0110	CENTER SUPPORT		179.3
2	4	400-000-3531-0102	T- FRAME		169.6
3	2	450-000-0702-0720	GRATING PANEL, 24" X 72"		84.3
4	2	450-000-0700-0034	GRATING PANEL, 24" X 35-7/8", W/CUT		39.7
5	4	450-000-0700-0035	GRATING PANEL, 35" X 34-3/4", W/CUT		57.39
6	16	000-MSG-0008	GRATING CLIP, 1", GALV.		0.20
7	24	COMMON	BOLT, HEX HD, .75-10UNC X 2.25 LG, ASTM A325, GALV		0.46
8	24	002-0NG-0019	NUT, HX, .75-10UNC, GR DH, GALV		0.2
9	24	002-0LW-G003	WASHER, SPLIT LOCK, .75 INCH, GALV		0.04
10	48	002-0FW-G003	WASHER, FLAT, .75 INCH, ASTM F436, GALV		0.03

OLD PART#: MATERIAL: SEE PARTS LIST THIRD ANGLE PROJECTION SURFACE FINISH <input checked="" type="checkbox"/> UNLESS OTHERWISE SPECIFIED	UNLESS OTHERWISE SPECIFIED DIMENSIONS ARE IN INCHES TOLERANCES .0 ± .1 .00 ± .03 .000 ± .005 FRACTIONS ± 1/16 ANGLES ± .25 ALL HOLES: LESS THAN 1.00 ± .012 1.00 AND OVER ± .031 FRACTIONS ± 1/32	APPROVALS DRAWN C. SANCHEZ CHECKED ENGINEER/DESIGNER PRODUCTION	DATE 5.09.14	 ELECTRO MECHANICAL INDUSTRIES, INC. 11230 NEESHAW DRIVE HOUSTON, TEXAS 77065 1-800-453-0050
TITLE: <b>6' X 6' BALLAST FOUNDATION</b>				SCALE: 1:10 WEIGHT: 1356 lbs. SHEET 1 OF 1
SIZE DRAWING NO. 400-000-3531-				REV