

THE INFORMATION CONTAINED IN THIS DRAWING IS THE SOLE PROPERTY OF ELECTRO MECHANICAL INDUSTRIES, INC. ANY REPRODUCTION IN PART OR WHOLE WITHOUT THE WRITTEN PERMISSION OF ELECTRO MECHANICAL IND., IS PROHIBITED.

REVISIONS					
REV.	DCN #	DESCRIPTION	DATE	BY	APPROVED
4	00869	UPDATED HARDWARE AND ADDED BOM COLUMNS	12.30.20	BLH	JPB

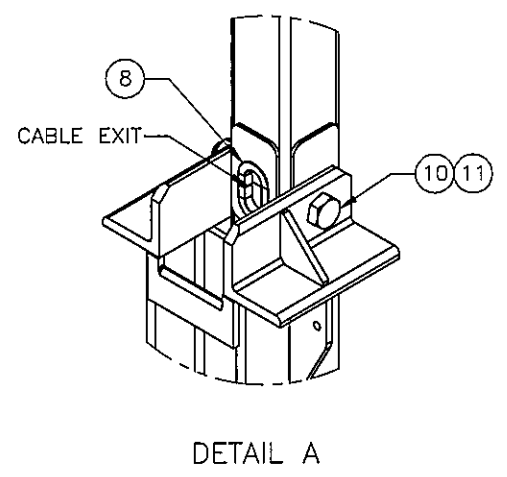
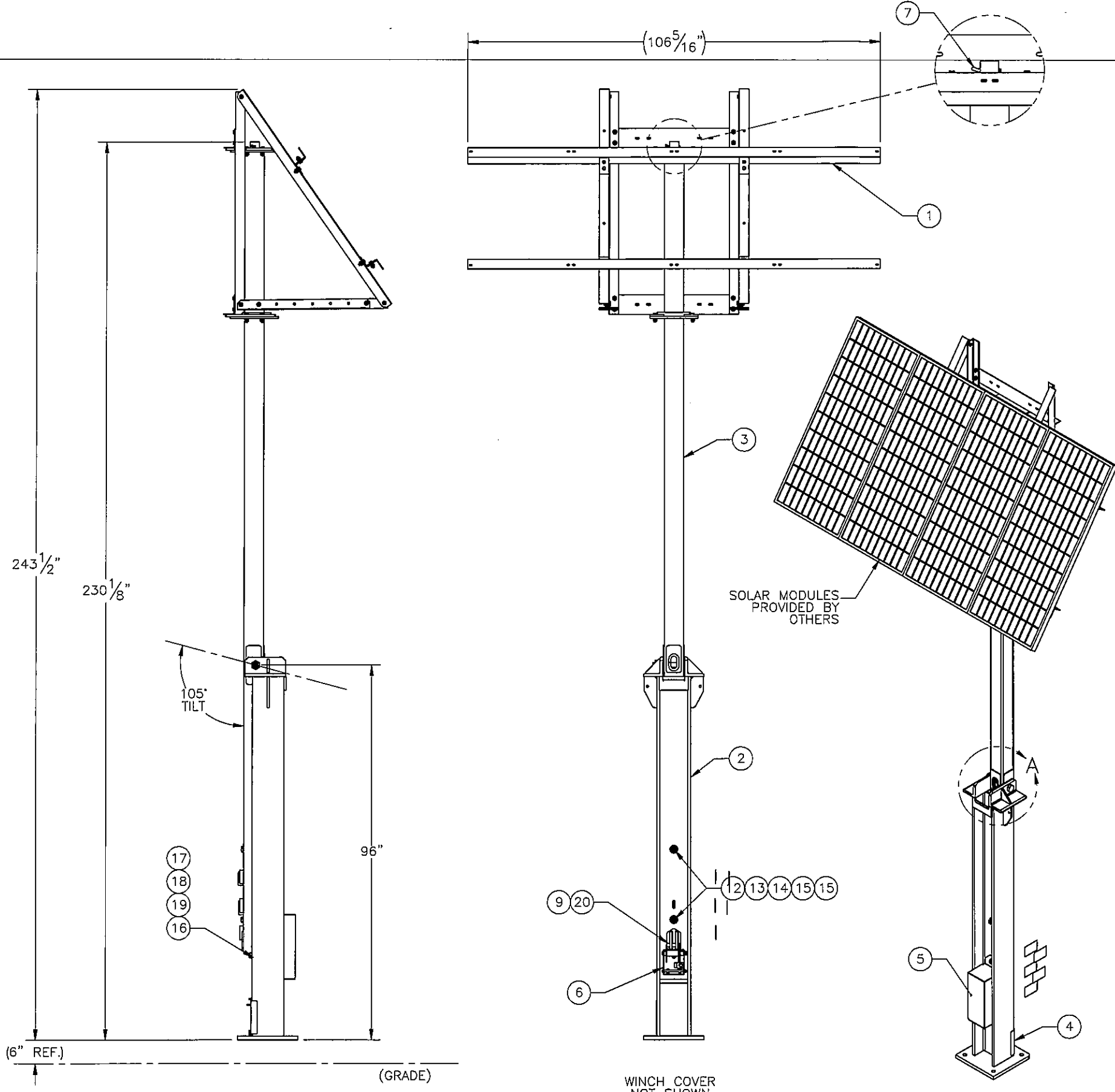

ITEM NO.	QTY REQD	PART NUMBER	DESCRIPTION	LENGTH	Weight
1	1	400-004-1840-0050	4 SOLAR MODULE FRAME ASSEMBLY		240.8
2	1	400-004-1850-0100	SUPPORT BASE ASSEMBLY		570.4
3	1	400-004-1850-0200	MAST ASSEMBLY		307.08
4	1	400-004-1850-0129	FRONT COVER		1.98
5	1	400-004-3050-0612	WINCH COVER		8.740
6	1	1002-0050-0003	WINCH KIT (1/4" X 14' WIRE ROPE)		8.7
7	1	002-00H-Z003	.375" DIA. X 3.00" LG. BENT HITCH PIN		0.13
8	1	309-000-0002-10	EDGE GUARD, 1/2", 10" LG.	10"	0.060
9	2	002-00C-0002	COTTER PIN, .188 DIA. X 1.50 LG, GALV		0.007
10	1	002-0BG-0032	BOLT, HX HD, 1.25-7UNC X 9.00 LG, A325, GALV		3.81
11	1	002-0NG-0020	NUT, HX, ANCO LOCKNUT, 1.25-7UNC, GR 2H, GALV		0.79
12	2	002-0BG-0007	BOLT, HX HD, .75-10UNC X 8.00 LG, A325, GALV		1.16
13	2	002-0NG-0002	NUT, HX, .75-10UNC, GR 2H, GALV		0.19
14	2	002-0LW-G003	WASHER, SPLIT LOCK, .75", GALV		0.04
15	4	002-0FW-G000	WASHER, FLAT, .75 INCH, USS, GALV		0.09
16	4	002-0SG-0000	SCREW, CAP, .25-20UNC X 1.00 LG, A307, GALV		0.02
17	4	002-0NG-0014	NUT, HEX, .25-20UNC, GR 2H, GALV		0.01
18	4	002-0LW-G009	WASHER, SPLIT LOCK, .25 INCH, GALV		0.00
19	4	002-0FW-G006	WASHER, FLAT, .25 INCH, TYPE A, GALV		0.00
20	1	400-004-3054-0071	.875" DIA. X 5.75" LG. PIN		0.956
21	2	999-999-L001	3.5" x 5" DO NOT CLIMB DECAL		0.006
22	2	999-999-L002	3.5" x 5" PINCH POINT DECAL		0.006
23	1	999-999-L003	3.5" x 5" WINCH RATING DECAL		0.006

SURFACE FINISH <input checked="" type="checkbox"/> UNLESS OTHERWISE SPECIFIED		UNLESS OTHERWISE SPECIFIED DIMENSIONS ARE IN INCHES		APPROVALS		DATE	
MATERIAL SEE PARTS LIST		TOLERANCES		DRAWN CS		12.05.11	
THIRD ANGLE PROJECTION		.0 ± .06 .00 ± .01 .000 ± .005		CHECKED LC		1.13.12	
NEXT ASSY		FRACTIONS ± 1/16		ENGINEER/DESIGNER VGD		12.05.11	
USED ON		ANGLES ± .25°		PRODUCTION JKS		3.13.12	
APPLICATIONS		HOLES: DRILLED OR PUNCHED +1/32 BURNED ±1/32		TITLE:		20' TILT-UP SOLAR TOWER, 4 MODULE	
				SIZE		DRAWING NO.	
				B		400-004-1840	
				SCALE: 1:64		WEIGHT: 1146.9 lbs.	
				SHEET 1 OF 1		REV 4	

EMI PRODUCTS, LLC
11230 NEESHAW DRIVE
HOUSTON, TEXAS 77065
1-800-453-0050