

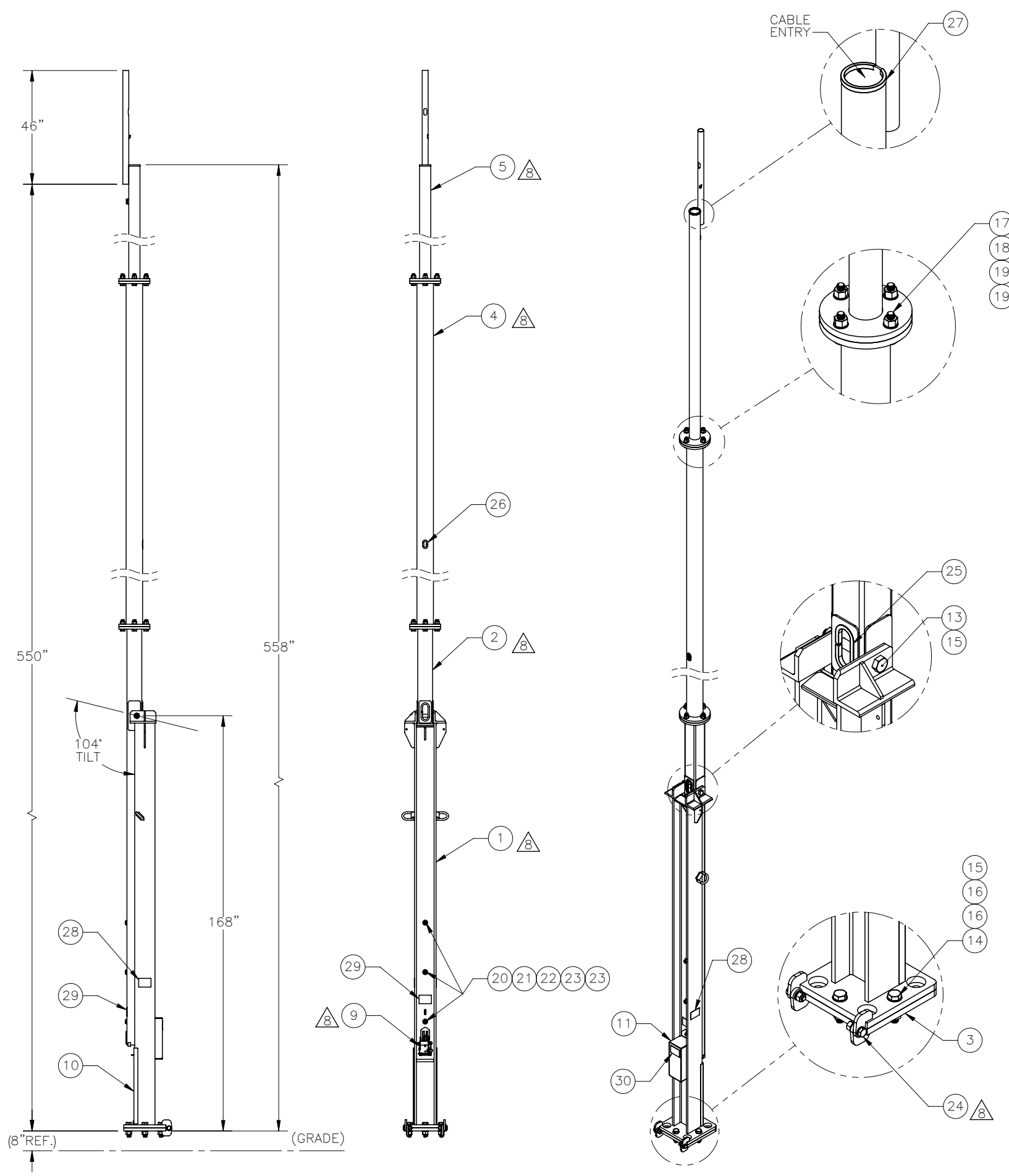

THE INFORMATION CONTAINED IN THIS DRAWING IS THE SOLE PROPERTY OF ELECTRO MECHANICAL INDUSTRIES, INC. ANY REPRODUCTION IN PART OR WHOLE WITHOUT THE WRITTEN PERMISSION OF ELECTRO MECHANICAL IND., IS PROHIBITED.

REVISIONS					
REV.	DCN #	DESCRIPTION	DATE	BY	APPROVED
8	01123	REMOVED .375 HW (INCLUDED IN SUB-ASSY NOW), LABELED ALL DECALS, .875 HW MOVED TO KIT 1000-0020-0105, FIXED MATES DUE TO LOWER LEVEL CHANGES.	03/03/2022	JTR	JPB

110 MPH EIA/TIA REV G
PATENT PENDING: #61322706

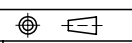

ITEM NO.	QTY REQD	PART NUMBER	DESCRIPTION	LENGTH	WEIGHT
1	1	400-004-4010-0100	SUPPORT BASE ASSEMBLY		953.05
2	1	400-004-4010-0210	LOWER SQUARE MAST ASSEMBLY		303.6
3	1	400-004-5000-0130	LOWER BASE PLATE ASSEMBLY		100.1
4	1	400-004-5000-0310	MIDDLE ROUND MAST ASSEMBLY		427.1
5	1	400-004-4010-0320	UPPER ROUND MAST ASSEMBLY		144.17
6	1	400-004-5000-0071	.875 DIA. X 6.75 LG. PIN		1.13
7	1	400-004-5000-0072	.875 DIA. X 2.25 LG. PIN		0.36
8	1	400-004-5000-0080	4" SHEAVE ASSEMBLY		2.37
9	1	1002-0050-0013	WINCH KIT (1/4" X 41' WIRE ROPE)		1.9
10	1	400-004-5010-0135	FRONT COVER		8.23
11	1	400-004-3050-0612	WINCH COVER		8.717
12	4	002-00C-0002	COTTER PIN, .187 X 1.50 LG, GALV		0.01
13	1	002-0BG-0035	BOLT, 1.25-7UNC X 10.00 LG, ASTM A325, GALV		4.15
14	4	002-0BG-0031	BOLT, HX HD, 1.25-7UNC X 5.00 LG, GR B7, GALV		2.38
15	5	002-0NG-0020	NUT, HX, ANCO LOCKNUT, 1.25-7UNC, GR 2H, GALV		0.79
16	8	002-0FW-G011	WASHER, FLAT, 1.25, ASTM F436, GALV		0.13
17	8	002-0BG-0210	BOLT, HX HD, 1.00-8 X 4.00 LG, ASTM A193 GR B7, GALV		1.21
18	8	002-0NG-0000	NUT, HX, ANCO LOCK, 1.00-8UNC, GR 2H, GALV		0.43
19	16	002-0FW-G009	WASHER, FLAT, 1.00", F436, GALV.		0.08
20	3	002-0BG-0029	BOLT, HX HD, .75-10UNC X 9.00 LG, ASTM A325, GALV		1.29
21	3	002-0NG-0002	NUT, HX, .75-10UNC, GR 2H, GALV		0.19
22	3	002-0LW-G003	WASHER, SPLIT LOCK, .75", GALV		0.04
23	6	002-0FW-G000	WASHER, FLAT, .75 INCH, USS, GALV		0.09
24	1	1000-0020-0105	TILT-UP TOWER DUAL HINGE .875" HARDWARE KIT		2.619
25	1	309-000-0002-15	EDGE GUARD, 1/2", 15" LG,	15"	0.102
26	1	309-000-0003-11	EDGE GUARD, 1/4", 11" LG.	11"	0.0
27	1	309-000-0001-12	EDGE GUARD, 3/16", 12" LG	12"	0.1
28	2	999-999-L001	3.5" x 5" DO NOT CLIMB DECAL		0.006
29	2	999-999-L002	3.5" x 5" PINCH POINT DECAL		0.006
30	1	999-999-L003	3.5" x 5" WINCH RATING DECAL		0.006

SURFACE FINISH <input checked="" type="checkbox"/> UNLESS OTHERWISE SPECIFIED		UNLESS OTHERWISE SPECIFIED DIMENSIONS ARE IN INCHES		APPROVALS		DATE		 ELECTRO MECHANICAL INDUSTRIES, INC. 11230 NEESESHAW DRIVE HOUSTON, TEXAS 77065 1-800-453-0050	
MATERIAL SEE PARTS LIST		TOLERANCES .00 ±.06 .000 ±.015 .000 ±.005		DRAWN C. SANCHEZ		8/4/2014		TITLE: 50' TILT-UP TOWER	
THIRD ANGLE PROJECTION 		FRACTIONS ± 1/16 ANGLES ± .25°		CHECKER J. HALL		8/12/2014			
NEXT ASSY		DRILLED OR PUNCHED ± 1/32		ENGINEER VGD		8/14/2014			
USED ON		HOLES: ± 1/32		PRODUCTION J. CRAIG		8/12/2014		SIZE B	
APPLICATIONS		BURNED ± 1/32						DRAWING NO. 400-004-4010	
								REV 8	
								SCALE: 1:48	
								WEIGHT: 1991.73 lbs.	
								SHEET 1 OF 1	