

THE INFORMATION CONTAINED IN THIS DRAWING IS THE SOLE PROPERTY OF ELECTRO MECHANICAL INDUSTRIES, INC. ANY REPRODUCTION IN PART OR WHOLE WITHOUT THE WRITTEN PERMISSION OF ELECTRO MECHANICAL IND., IS PROHIBITED.

REVISIONS					
REV.	DCN #	DESCRIPTION	DATE	BY	APPROVED
6	01123	002-0BG-0210 TO 002-0BG-0001, 002-0NG-0019 TO 002-0NG-0002, (MCM) 24175K18 TO 309-000-0002-15, (MCM) 24178K16 TO 309-000-0003-11, 400-004-5000-0073 TO 309-000-0001-10, .875 HW TO 1000-0020-0105, ADDED DECALS, UPDATED WITH LOWER LEVEL CHANGES.	04/11/2022	JTR	JPB

90 MPH EIA/TIA REV G
PATENT PENDING: #61322706

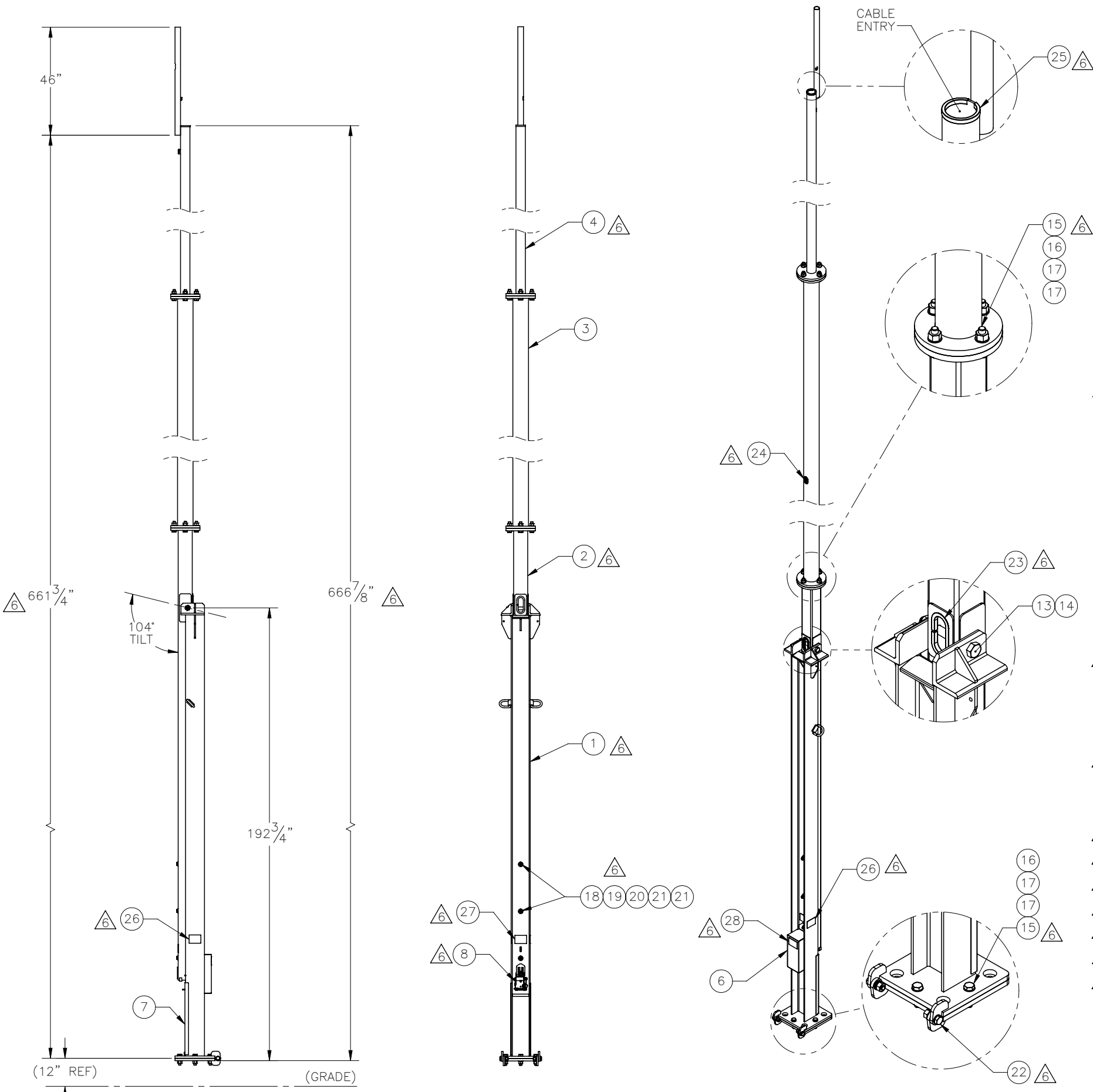

ITEM NO.	QTY REQD	PART NUMBER	DESCRIPTION	LENGTH	WEIGHT
1	1	400-004-5001-0100	SUPPORT BASE ASSEMBLY		700.68
2	1	400-004-5000-0210	LOWER SQUARE MAST ASSEMBLY		340.4
3	1	400-004-5000-0310	MIDDLE ROUND MAST ASSEMBLY		427.1
4	1	400-004-5000-0320	UPPER ROUND MAST ASSEMBLY		194.9
5	1	400-004-3054-0130	HINGE BASE		81.59
6	1	400-004-3050-0612	WINCH COVER		8.740
7	1	400-004-5000-0129	FRONT COVER		7.577
8	1	1002-0050-0007	WINCH KIT (1/4" X 47' WIRE ROPE)		1.9
9	1	400-004-5000-0080	4" SHEAVE ASSEMBLY		2.37
10	1	400-004-5000-0071	.875 DIA. X 6.75 LG. PIN		1.13
11	1	400-004-5000-0072	.875 DIA. X 2.25 LG. PIN		0.36
12	4	002-00C-0002	COTTER PIN, .187 X 1.50 LG, GALV		0.01
13	1	002-0BG-0035	BOLT, 1.25-7UNC X 10.00 LG, ASTM A325, GALV		4.15
14	1	002-0NG-0020	NUT, HX, ANCO LOCKNUT, 1.25-7UNC, GR 2H, GALV		0.79
15	12	002-0BG-0001	HHB, HVY, HX, HD., 1.00-8 X 4.00 LG., PT X 1.75, A325, HDG	4.00	1.3
16	12	002-0NG-0000	NUT, HX, ANCO LOCK, 1.00-8UNC, GR 2H, GALV		0.43
17	24	002-0FW-G009	WASHER, FLAT, 1.00", F436, GALV.		0.08
18	3	002-0BG-0029	BOLT, HX HD, .75-10UNC X 9.00 LG, ASTM A325, GALV		1.29
19	3	002-0NG-0002	NUT, HX, .75-10UNC, GR 2H, GALV		0.19
20	3	002-0LW-G003	WASHER, SPLIT LOCK, .75", GALV		0.04
21	6	002-0FW-G000	WASHER, FLAT, .75 INCH, USS, GALV		0.09
22	1	1000-0020-0105	TILT-UP TOWER HINGE .875" HARDWARE KIT		2.619
23	1	309-000-0002-15	EDGE GUARD, 1/2", 15" LG,	15"	0.102
24	1	309-000-0003-11	EDGE GUARD, 1/4", 11" LG.	11"	0.0
25	1	309-000-0001-10	EDGE GUARD, 3/16", 10" LG	10"	0.0
26	2	999-999-L001	3.5" x 5" DO NOT CLIMB DECAL		0.006
27	2	999-999-L002	3.5" x 5" PINCH POINT DECAL		0.006
28	1	999-999-L003	3.5" x 5" WINCH RATING DECAL		0.006

SURFACE FINISH <input checked="" type="checkbox"/> UNLESS OTHERWISE SPECIFIED		UNLESS OTHERWISE SPECIFIED DIMENSIONS ARE IN INCHES		APPROVALS		DATE	
MATERIAL SEE PARTS LIST		TOLERANCES 0 ±.06 .00 ±.015 .000 ±.005		DRAWN LC		2/24/2012	
THIRD ANGLE PROJECTION		FRACTIONS ± 1/16 ANGLES ± .25°		CHECKER VGD		2/27/2012	
NEXT ASSY		DRILLED OR PUNCHED ± 1/32		ENGINEER VGD		2/27/2012	
USED ON		HOLES: BURNED ± 1/32		PRODUCTION JKS		2/27/2012	
APPLICATIONS				TITLE:		60' TILT UP TOWER	
				SIZE B		DRAWING NO. 400-004-5001	
				SCALE: 1:192		WEIGHT: 1802.10 lbs.	
				SHEET 1 OF 1		REV 6	

