

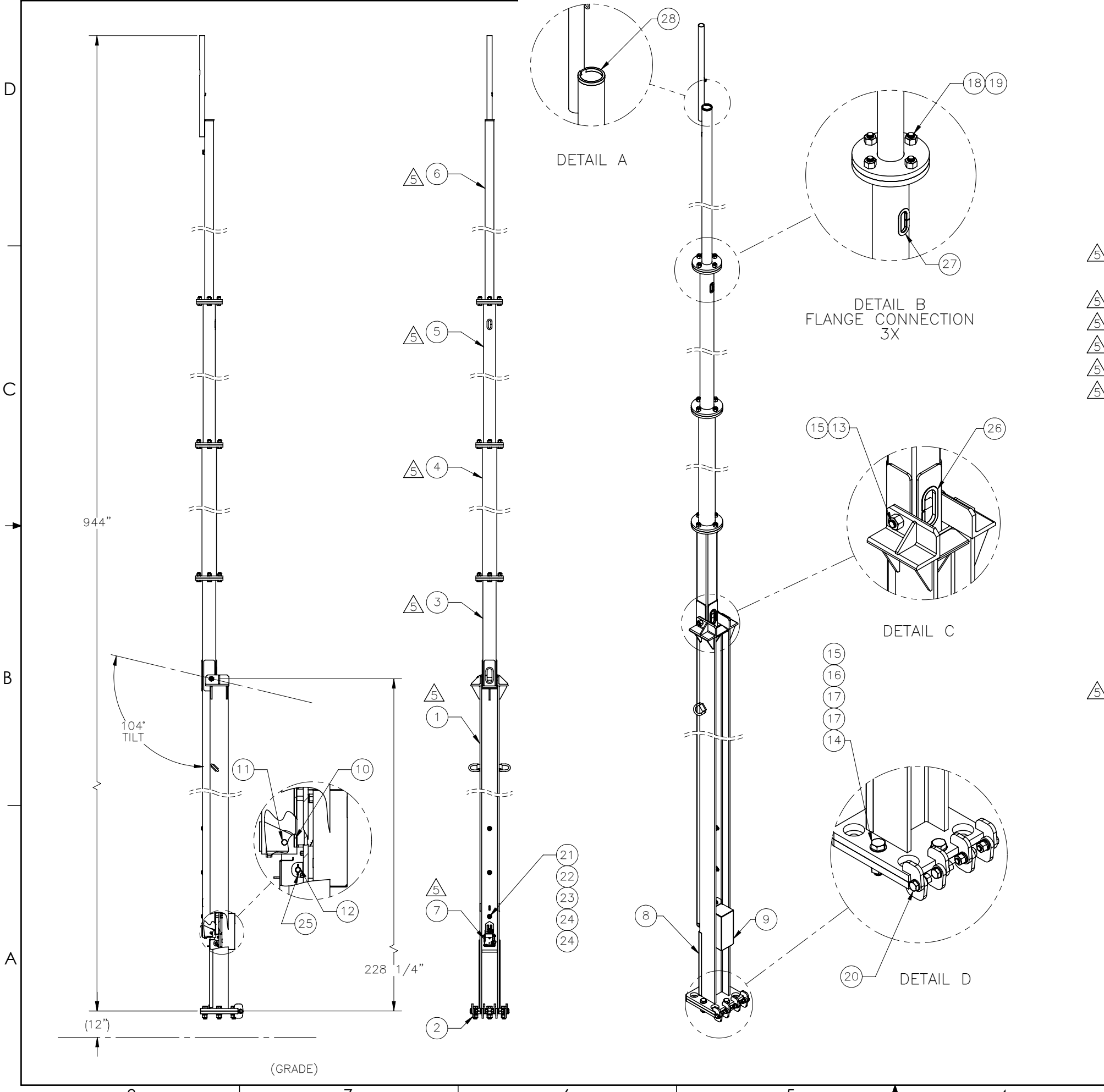

THE INFORMATION CONTAINED IN THIS DRAWING IS THE SOLE PROPERTY OF ELECTRO MECHANICAL INDUSTRIES, INC. ANY REPRODUCTION IN PART OR WHOLE WITHOUT THE WRITTEN PERMISSION OF ELECTRO MECHANICAL IND., IS PROHIBITED.

REVISIONS					
REV.	DCN #	DESCRIPTION	DATE	BY	APPROVED
5	01123	MATES CORRECTED DUE TO LOWER LEVEL CHANGES. .875 HINGE HW CHANGED TO KIT 1000-0020-0104	05/09/2022	JTR	JPB

90 MPH EIA/TIA REV G  
PATENT PENDING: #61322706

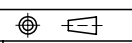

ITEM NO.	QTY REQD	PART NUMBER	DESCRIPTION	LENGTH	WEIGHT
5	1	400-004-5201-0100	SUPPORT BASE ASSEMBLY		1254.70
	1	A-000-016	LOWER HINGE PLATE ASSEMBLY		104.05
5	1	400-004-5201-0210	LOWER SQUARE MAST ASSEMBLY		433.95
5	1	400-004-5201-0215	LOWER ROUND MAST ASSEMBLY		324.45
5	1	400-004-5201-0220	MIDDLE MAST ASSEMBLY		296.36
5	1	400-004-5201-0230	UPPER MAST ASSEMBLY		230.88
5	1	1002-0050-0014	WINCH KIT (1/4" X 56' WIRE ROPE)		1.9
	1	400-004-5010-0135	FRONT COVER		8.23
	1	400-004-3050-0612	WINCH COVER		8.717
	1	400-004-5000-0080	4" SHEAVE ASSEMBLY		2.37
	1	400-004-5000-0071	.875 DIA. X 6.75 LG. PIN		1.13
	1	400-004-5000-0072	.875 DIA. X 2.25 LG. PIN		0.36
	1	002-0BG-0035	BOLT, 1.25-7UNC X 10.00 LG, ASTM A325, GALV		4.15
	4	002-0BG-0031	BOLT, HX HD, 1.25-7UNC X 5.00 LG, GR B7, GALV		2.38
	5	002-0NG-0020	NUT, HX, ANCO LOCKNUT, 1.25-7UNC, GR 2H, GALV		0.79
	4	002-0LW-G001	WASHER, SPLIT LOCK, 1.25, GALV.		0.174
	8	002-0FW-G011	WASHER, FLAT, 1.25, ASTM F436, GALV		0.13
	12	002-0BG-0279	BOLT, HX. HD., 1.00-8, ASTM A325, GALV.	3.50	1.12
	12	002-0NG-0000	NUT, HX, ANCO LOCK, 1.00-8UNC, GR 2H, GALV		0.43
5	1	1000-0020-0104	TILT-UP TOWER QUAD HINGE .875" HARDWARE KIT		5.239
	3	002-0BG-0247	BOLT, HX HD, .75"-10 X 9.50" LG., ASTM A325, GALV.		1.35
	3	002-0NG-0002	NUT, HX, .75-10UNC, GR 2H, GALV		0.19
	3	002-0LW-G003	WASHER, SPLIT LOCK, .75", GALV		0.04
	6	002-0FW-G000	WASHER, FLAT, .75 INCH, USS, GALV		0.09
	4	002-0OC-0002	COTTER PIN, .188 DIA. X 1.50 LG, GALV		0.007
	1	309-000-0002-15	EDGE GUARD, 1/2", 15" LG,	15"	0.102
	1	309-000-0005-09	EDGE GUARD, 5/16", 9" LG.	9"	0.038
	1	309-000-0001-10	EDGE GUARD, 3/16", 10" LG	10"	0.0
	2	999-999-L001	3.5" x 5" DO NOT CLIMB DECAL		0.006
	2	999-999-L002	3.5" x 5" PINCH POINT DECAL		0.006
	1	999-999-L003	3.5" x 5" WINCH RATING DECAL		0.006

SURFACE FINISH <input checked="" type="checkbox"/> UNLESS OTHERWISE SPECIFIED		UNLESS OTHERWISE SPECIFIED DIMENSIONS ARE IN INCHES		APPROVALS		DATE		 ELECTRO MECHANICAL INDUSTRIES, INC. 11230 NEESESHAW DRIVE HOUSTON, TEXAS 77065 1-800-453-0050	
MATERIAL SEE PARTS LIST		TOLERANCES .0 ±.06 .00 ±.015 .000 ±.005 FRACTIONS ± 1/16 ANGLES ± .25° HOLES: DRILLED OR PUNCHED ± 1/32 BURNED ± 1/32		DRAWN CS		7/19/2012		TITLE: 80' TILT UP TOWER	
THIRD ANGLE PROJECTION 				CHECKER R. AVELAR		7/27/2012		SIZE B	
NEXT ASSY		USED ON		ENGINEER V.G.D.		7/27/2012		DRAWING NO. 400-004-5201	
APPLICATIONS				PRODUCTION J. SUNDERLAND		7/27/2012		REV 5	
								SCALE: 1:192 WEIGHT: 2715.71 lbs. SHEET 1 OF 1	