

THE INFORMATION CONTAINED IN THIS DRAWING IS THE SOLE PROPERTY OF ELECTRO MECHANICAL INDUSTRIES, INC. ANY REPRODUCTION IN PART OR WHOLE WITHOUT THE WRITTEN PERMISSION OF ELECTRO MECHANICAL IND., IS PROHIBITED.

REVISIONS					
REV.	DCN #	DESCRIPTION	DATE	BY	APPROVED
1	DCN00111	GIVE COMMON ITEMS PART #'S	2.29.16	JGC	<i>JGC</i>

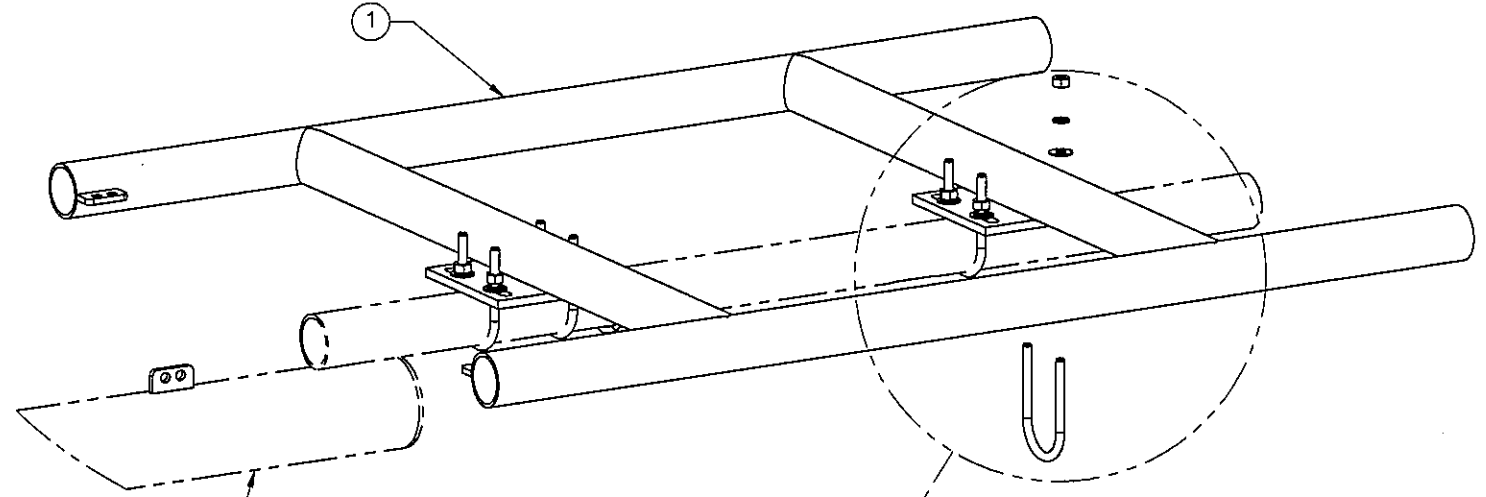

UPPER MAST SHOWN FOR REFERENCE ONLY

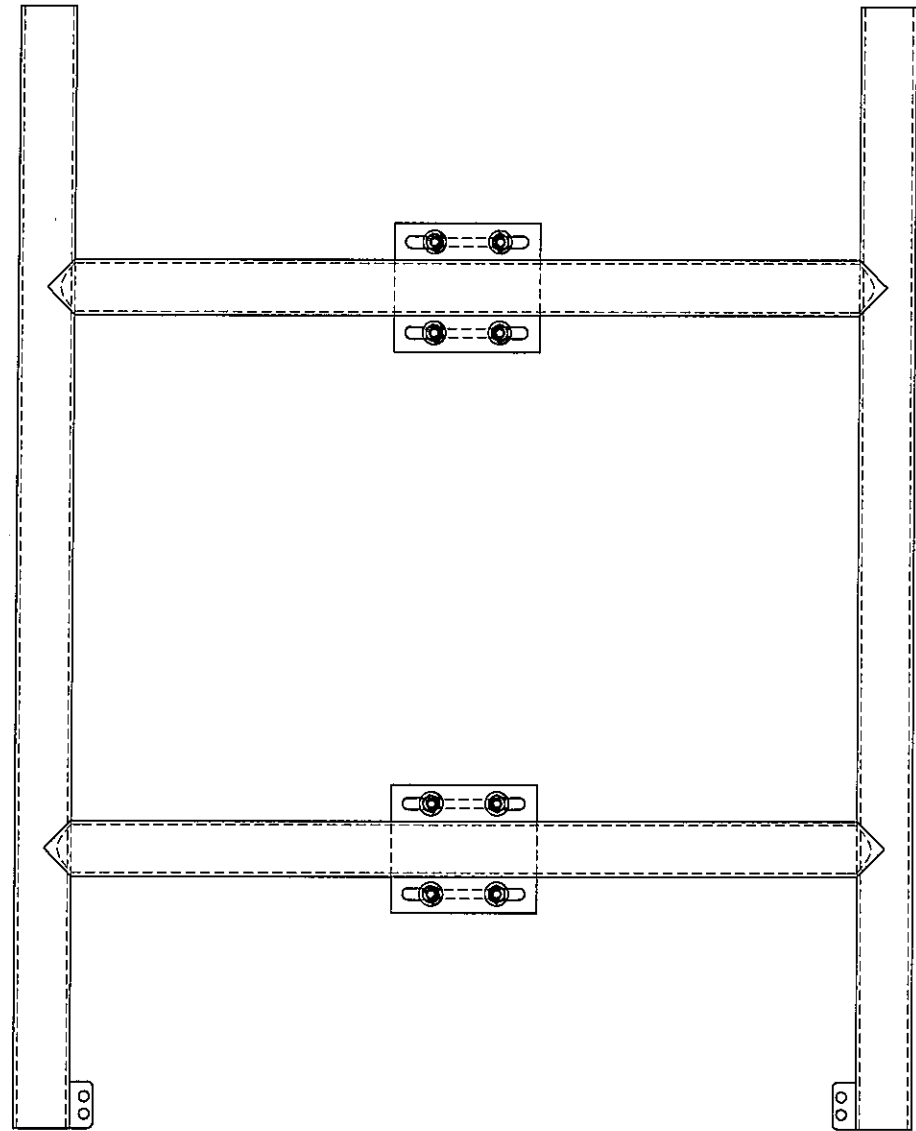
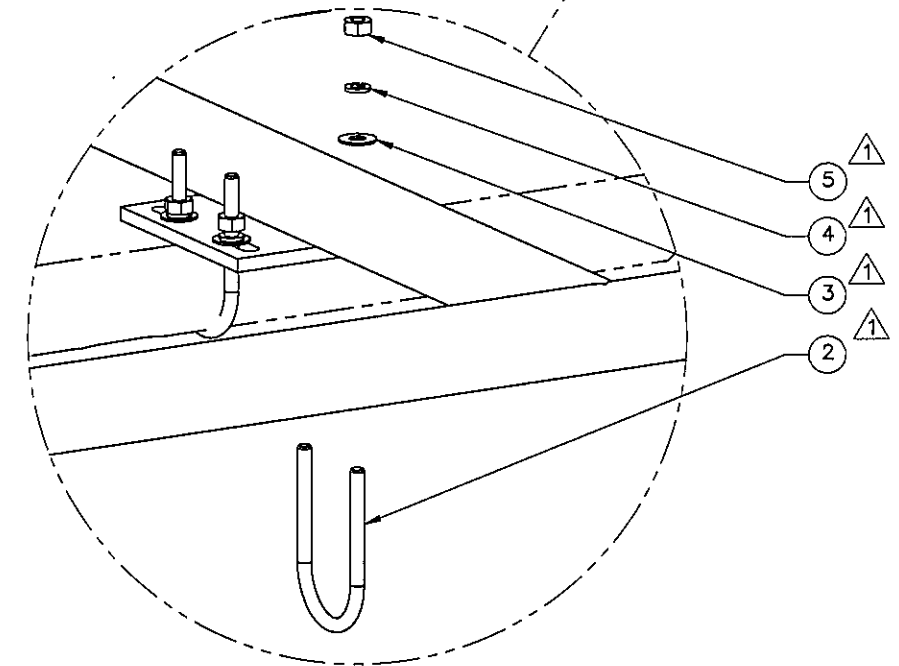

DETAIL A  
SCALE: 1 / 5

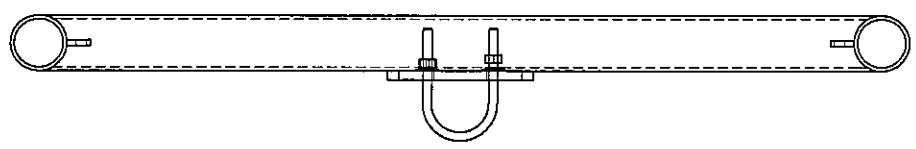

ITEM NO.	QTY. REQD	PART NUMBER	DESCRIPTION
1	1	400-904-0103-0100	ANTENNA H-FRAME
2	4	002-0UG-0000	U-BOLT, EXT. LENGTH, 3/8"-16 THD, 2" PIPE, GALV.
3	8	002-0FW-G005	WASHER, FLAT, .375, GALV.
4	8	002-0LW-G005	WASHER, SPLIT LOCK, .375 INCH, GALV
5	8	002-0NG-0003	NUT, HEX, .375-16UNC, GR 2H, GALV

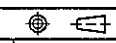
SURFACE FINISH <input checked="" type="checkbox"/> UNLESS OTHERWISE SPECIFIED		UNLESS OTHERWISE SPECIFIED DIMENSIONS ARE IN INCHES		APPROVALS		DATE		 EMI PRODUCTS, LLC 11230 NEESHAW DRIVE HOUSTON, TEXAS 77085 1-800-453-0050	
MATERIAL SEE BILL OF MATERIAL		TOLERANCES		DRAWN LC		8/12/11			
THIRD ANGLE PROJECTION 		.0 ± .1		CHECKED C. SANCHEZ		9.15.11		TITLE: <b>ANTENNA H-FRAME ASSEMBLY</b>	
NEXT ASSY USED ON		.000 ± .005		ENGINEER/DESIGNER C. SANCHEZ		9.15.11			
APPLICATIONS		FRACTIONS ± 1/16		PRODUCTION JKS		9.15.11		SIZE B DRAWING NO. 400-904-0103 REV 1	
		ANGLES ± .05°						SCALE: 1:8 SHEET 1 OF 1	
		HOLES:							
		.013 THRU .125 +.005							
		.126 THRU 1.500 +.012							
		-.002							
		-.003							