

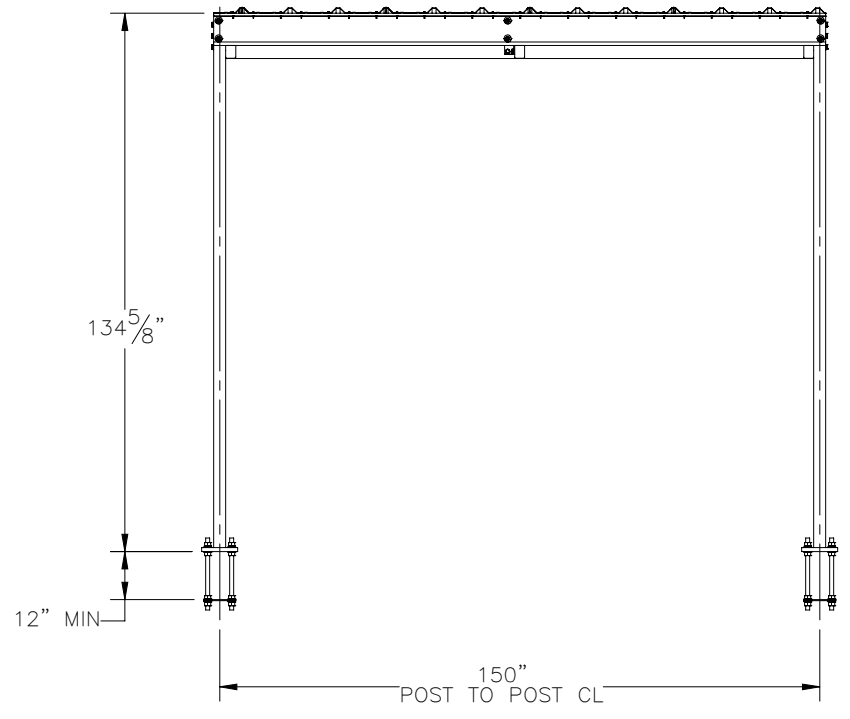

THE INFORMATION CONTAINED IN THIS DRAWING IS THE SOLE PROPERTY OF ELECTRO MECHANICAL INDUSTRIES, INC. ANY REPRODUCTION IN PART OR WHOLE WITHOUT THE WRITTEN PERMISSION OF ELECTRO MECHANICAL IND., IS PROHIBITED.

REVISIONS					
REV.	DCN #	DESCRIPTION	DATE	BY	APPROVED
1	01245	REMOVED P-005-637, ADJUSTED P-005-639 TO QTY 2	5/25/2023	BLH	JPB

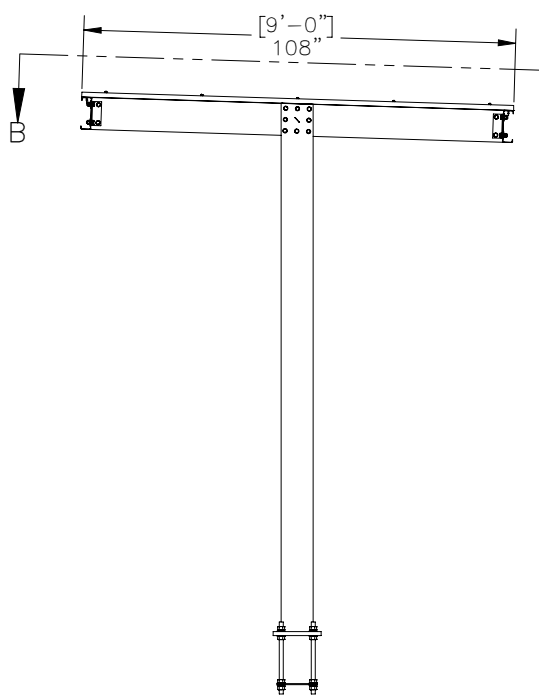
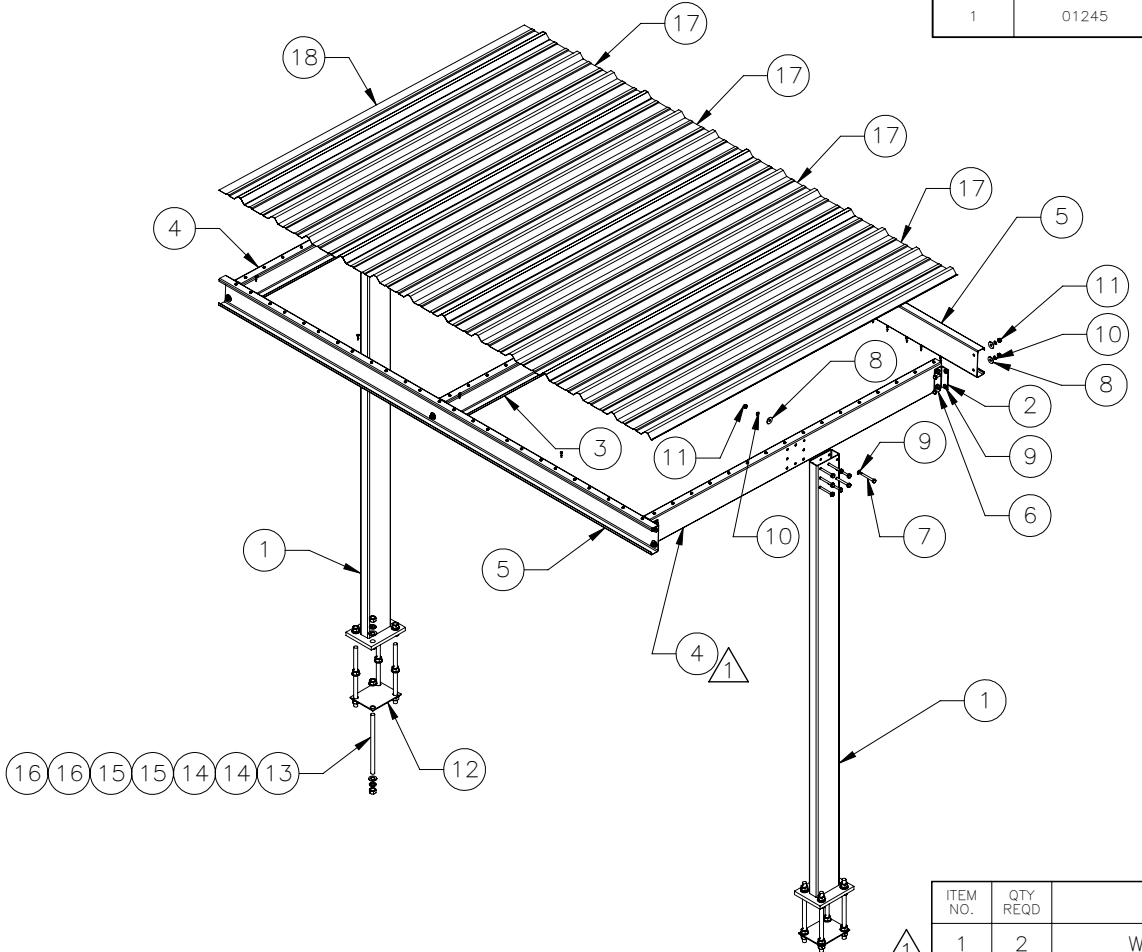
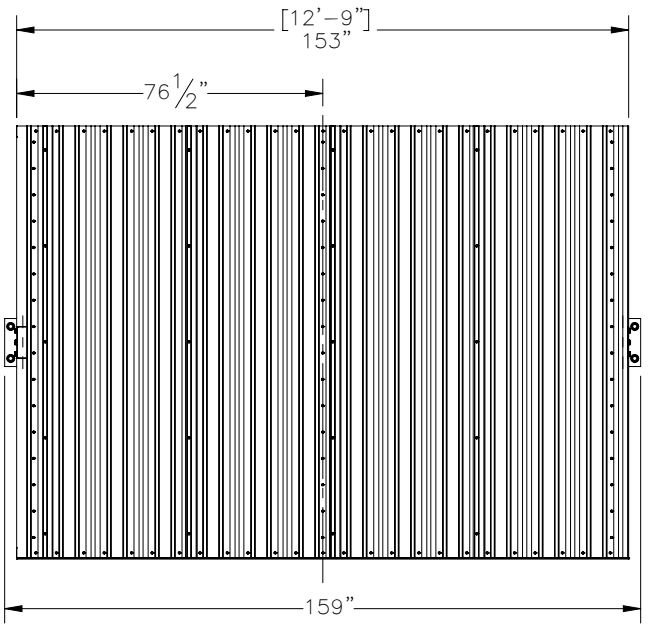

ITEM NO.	QTY REQD	PART NUMBER	DESCRIPTION	LENGTH	WEIGHT
1	2	W-002-583	POST, CANOPY WELDMENT		47.42
2	6	P-005-636	ANGLE CLIP		
3	1	P-005-638	C PURLIN SHORT ROOF RUNNER CENTER		42.75
4	2	P-005-639	C PURLIN SHORT ROOF RUNNER LEFT/RIGHT		42.69
5	2	P-005-640	C PURLIN LONG ROOF RUNNER		63.50
6	24	002-0BG-0010	BOLT, HH, .500-13 X 1.50, GALV, A325, PT X 1.00	1 1/2"	0.14
7	16	002-0BG-0317	BOLT, HH, .500-13 X 4.25, GALV, A325, PT X 1.00	4 1/4"	0.2953
8	40	002-0FW-G033	WASHER, FLAT, .500, GALV, 1.750" OD		0.01
9	40	002-0FW-G002	WASHER, FLAT, .500, GALV, F436		0.03
10	40	002-0LW-G002	WASHER, SPLIT LOCK, .500, GALV		0.014
11	40	002-0NG-0010	NUT, HEX, .500-13, GALV, GR 2H		0.06
12	2	P-005-648	BASE PLATE, LOWER	10"	5.32
13	8	002-0AT-G016	AT, 1.00-8 X 18.0, GALV, GR B7	18"	4.02
14	32	002-0FW-G009	WASHER, FLAT, 1.00, GALV, F436		0.10
15	16	002-0LW-G008	WASHER, SPLIT LOCK, 1.00, GALV		0.09
16	32	002-0NG-0008	NUT, HEX, 1.00-8, GALV, GR 2H		0.282
17	4	P-005-649	ROOF PANEL, 36" X 108", 24 GA. GALVALUME PLUS SSX	108	32.1
18	1	P-005-651	ROOF PANEL, 9-1/16" X 108", 24 GA. GALVALUME PLUS SSX	108	7.6
19	118	002-0SG-0007	#12 X 1 1/4" LG., SELF DRILLING SCREW W. WASHER, GALV.		0.02

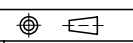
SURFACE FINISH <input checked="" type="checkbox"/> UNLESS OTHERWISE SPECIFIED		UNLESS OTHERWISE SPECIFIED DIMENSIONS ARE IN INCHES		APPROVALS		DATE		 ELECTRO MECHANICAL INDUSTRIES, INC. 11250 NEESEHAW DRIVE HOUSTON, TEXAS 77065 1-800-453-0050	
MATERIAL SEE PARTS LIST		TOLERANCES		DRAWN B. HUTSON		3/27/2023		TITLE:	
THIRD ANGLE PROJECTION 		.0 ±.06 .00 ±.015 .000 ±.005		CHECKER J. ROACH		3/27/2023		9' x 12'-9" CABINET CANOPY	
NEXT ASSY		FRACTIONS ± 1/16 ANGLES ± .25°		ENGINEER J. Breen		3/29/2023			
USED ON		HOLES: DRILLED OR PUNCHED ±1/32		PRODUCTION J. KERNER		3/29/2023		SIZE B	
APPLICATIONS		BURNED ±1/32						DRAWING NO. 1000-0000-0221	
								REV 1	
								SCALE: 1:48	
								WEIGHT: 569.29 lbs.	
								SHEET 1 OF 2	

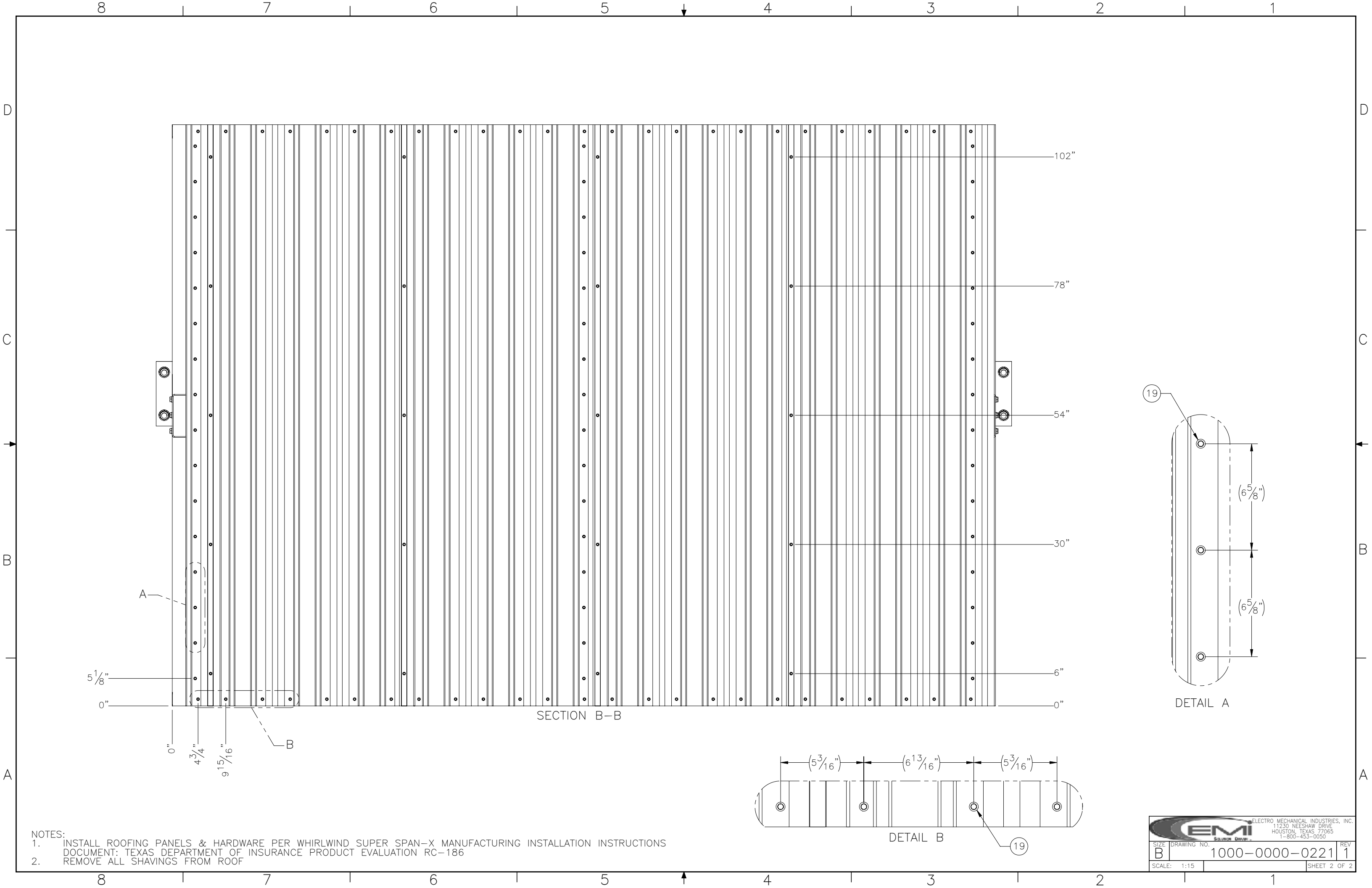

SECTION B-B

DETAIL A

DETAIL B

- NOTES:
1. INSTALL ROOFING PANELS & HARDWARE PER WHIRLWIND SUPER SPAN-X MANUFACTURING INSTALLATION INSTRUCTIONS
 2. REMOVE ALL SHAVINGS FROM ROOF

		ELECTRO MECHANICAL INDUSTRIES, INC. 11230 NEESHAW DRIVE HOUSTON, TEXAS 77065 1-800-453-0050	
SIZE	DRAWING NO.	REV	
B	1000-0000-0221	1	
SCALE:	1:15		SHEET 2 OF 2