

THE INFORMATION CONTAINED IN THIS DRAWING IS THE SOLE PROPERTY OF ELECTRO MECHANICAL INDUSTRIES, INC. ANY REPRODUCTION IN PART OR WHOLE WITHOUT THE WRITTEN PERMISSION OF ELECTRO MECHANICAL IND., IS PROHIBITED.

GENERAC SD130 130KW GENERATOR AND 460G BASETANK PROVIDED BY CUSTOMER

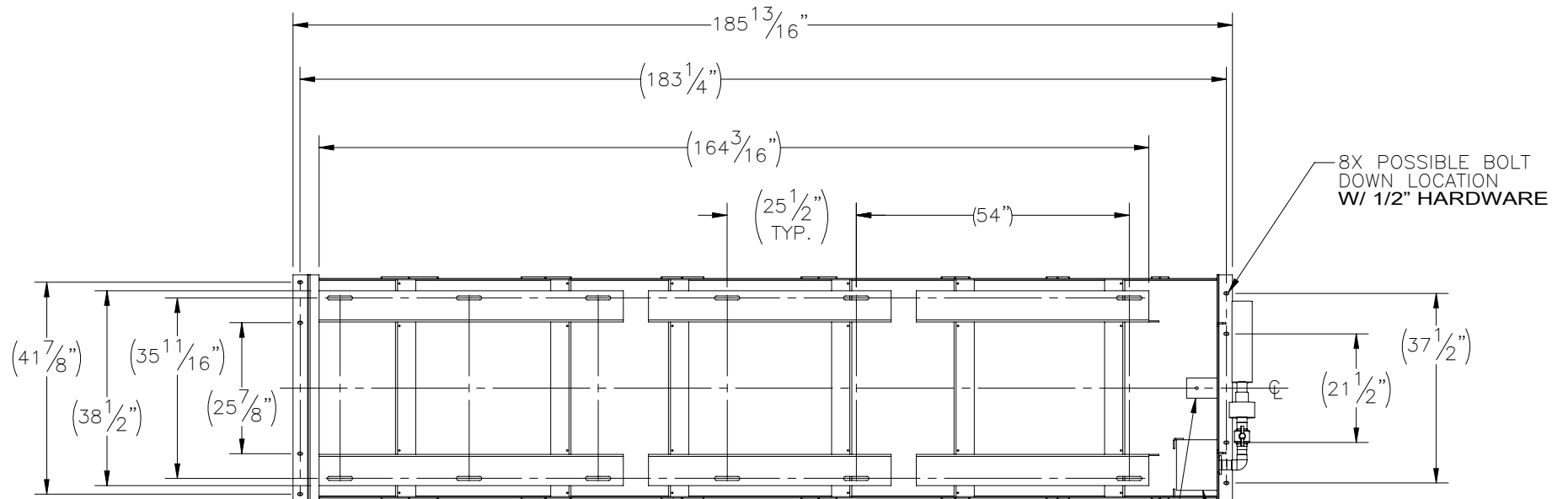

DIAMOND PLATE AND GRATING NOT SHOWN

FLOAT ALARM BRACKET

8X POSSIBLE BOLT DOWN LOCATION W/ 1/2" HARDWARE

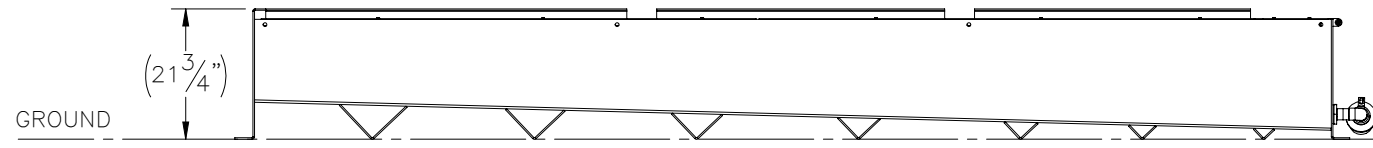
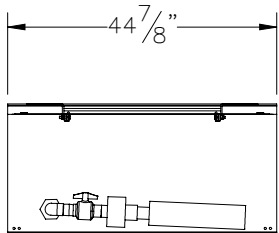
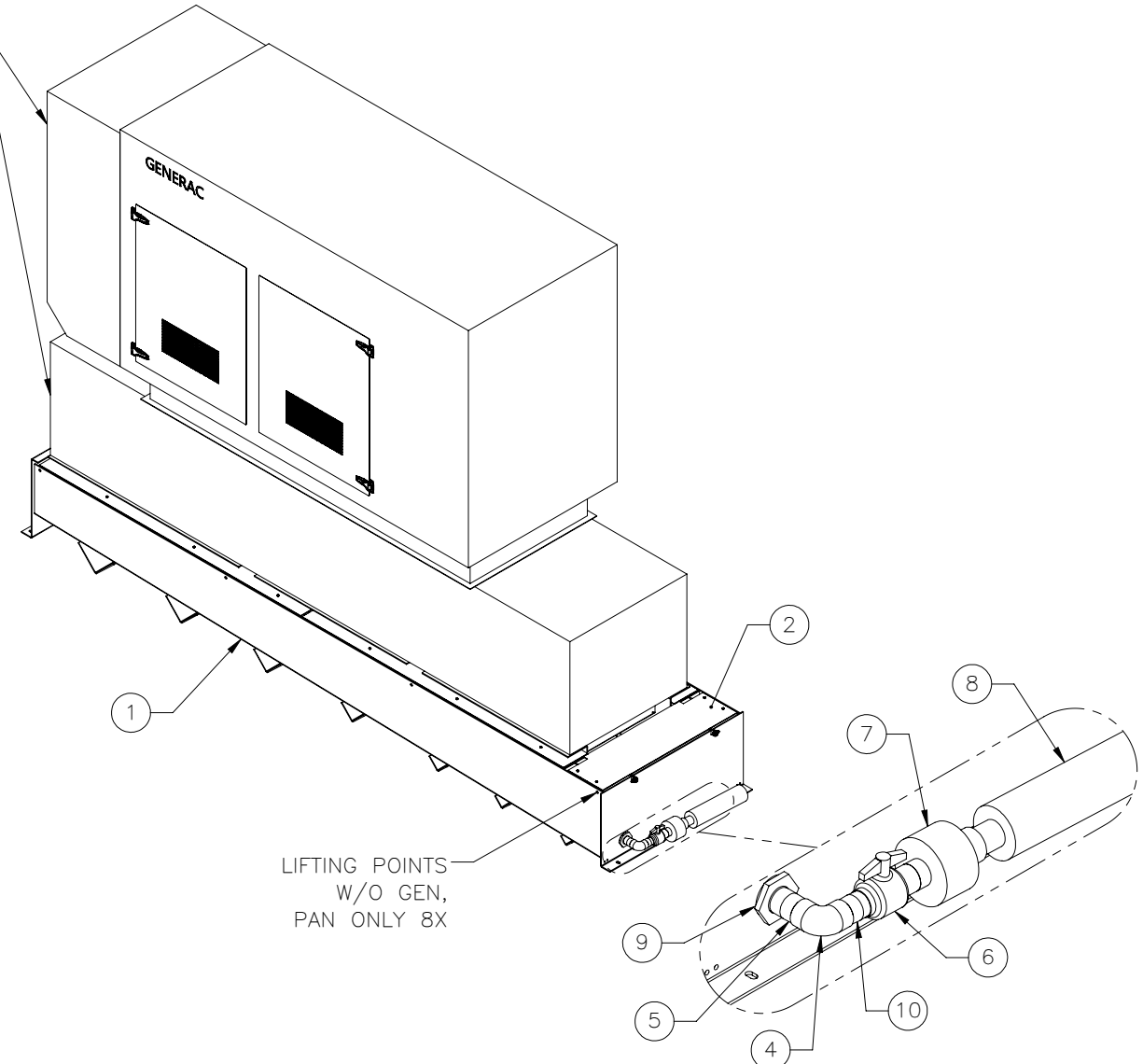

ITEM NO.	QTY REQD	PART NUMBER	DESCRIPTION	LENGTH	WEIGHT
1	1	W-002-644	GENERATOR PAN WELDMENT		2024.35
2	1	A-000-734	DIAMOND PLATE COVER ASSEMBLY		191.7
3	1	175-0FB-0001	PFB-810 PRE-FILTER BASKET ALUMINUM		5.2
4	1	175-00E-9001	1.5" PVC 90 DEG ELBOW		0.01
5	1	175-00N-0006	1.5" DIA DARK GRAY PVC PIPE NIPPLE	3"	0.11
6	1	175-0BV-0003	1.5" PVC BALL VALVE	4 11/16"	0.01
7	1	175-00F-0002	SPI, PRE-FILTER		0.07
8	1	175-00F-0001	OIL SPILL FILTER, 1.5" MALE THREADED FITTING	16"	0.21
9	1	175-TWF-0001	PVC, NPT FEMALE ON BOTH ENDS, 1.50" PIPE SIZE, 3" LONG		0.47
10	1	175-00N-0007	1.5" PVC THREADED BOTH END NIPPLE	2"	0.07
11	1	P-006-606	RODENT GUARD	36"	2.72

NOTE:
1. ASSEMBLE PER INDUSTRY STANDARDS.

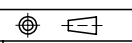
SURFACE FINISH <input checked="" type="checkbox"/> UNLESS OTHERWISE SPECIFIED		UNLESS OTHERWISE SPECIFIED DIMENSIONS ARE IN INCHES		APPROVALS		DATE		 ELECTRO MECHANICAL INDUSTRIES, INC. 11230 NEESESHAW DRIVE HOUSTON, TEXAS 77065 1-800-453-0050	
MATERIAL SEE PARTS LIST		TOLERANCES .0 ±.06 .00 ±.015 .000 ±.005 FRACTIONS ± 1/16 ANGLES ± .25° HOLES: DRILLED OR PUNCHED ± 1/32 BURNED ± 1/32		DRAWN J. ROACH		7/5/2023		TITLE: GEN PAN 460 GAL	
THIRD ANGLE PROJECTION 				CHECKER B. HUTSON		7/6/2023		SIZE B DRAWING NO. 1015-0000-0057	
NEXT ASSY		USED ON		ENGINEER J. Breen		7/6/2023		REV 0	
APPLICATIONS				PRODUCTION J. KERNER		7/6/2023		SCALE: 1:32 WEIGHT: 2224.9 lbs. SHEET 1 OF 1	