

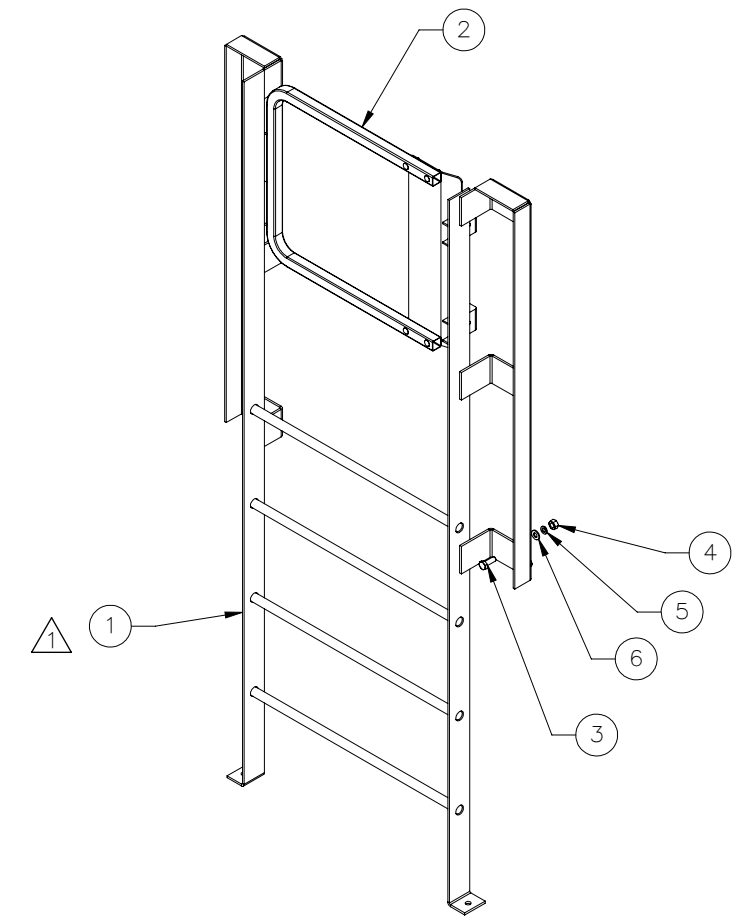

THE INFORMATION CONTAINED IN THIS DRAWING IS THE SOLE PROPERTY OF ELECTRO MECHANICAL INDUSTRIES, INC. ANY REPRODUCTION IN PART OR WHOLE WITHOUT THE WRITTEN PERMISSION OF ELECTRO MECHANICAL IND., IS PROHIBITED.

| REVISIONS | | | | | |
|-----------|-------|-----------------------------------|------------|-----|----------|
| REV. | DCN # | DESCRIPTION | DATE | BY | APPROVED |
| 1 | 01213 | UPDATED WITH LOWER LEVEL CHANGES. | 01/25/2023 | JTR | JPB |

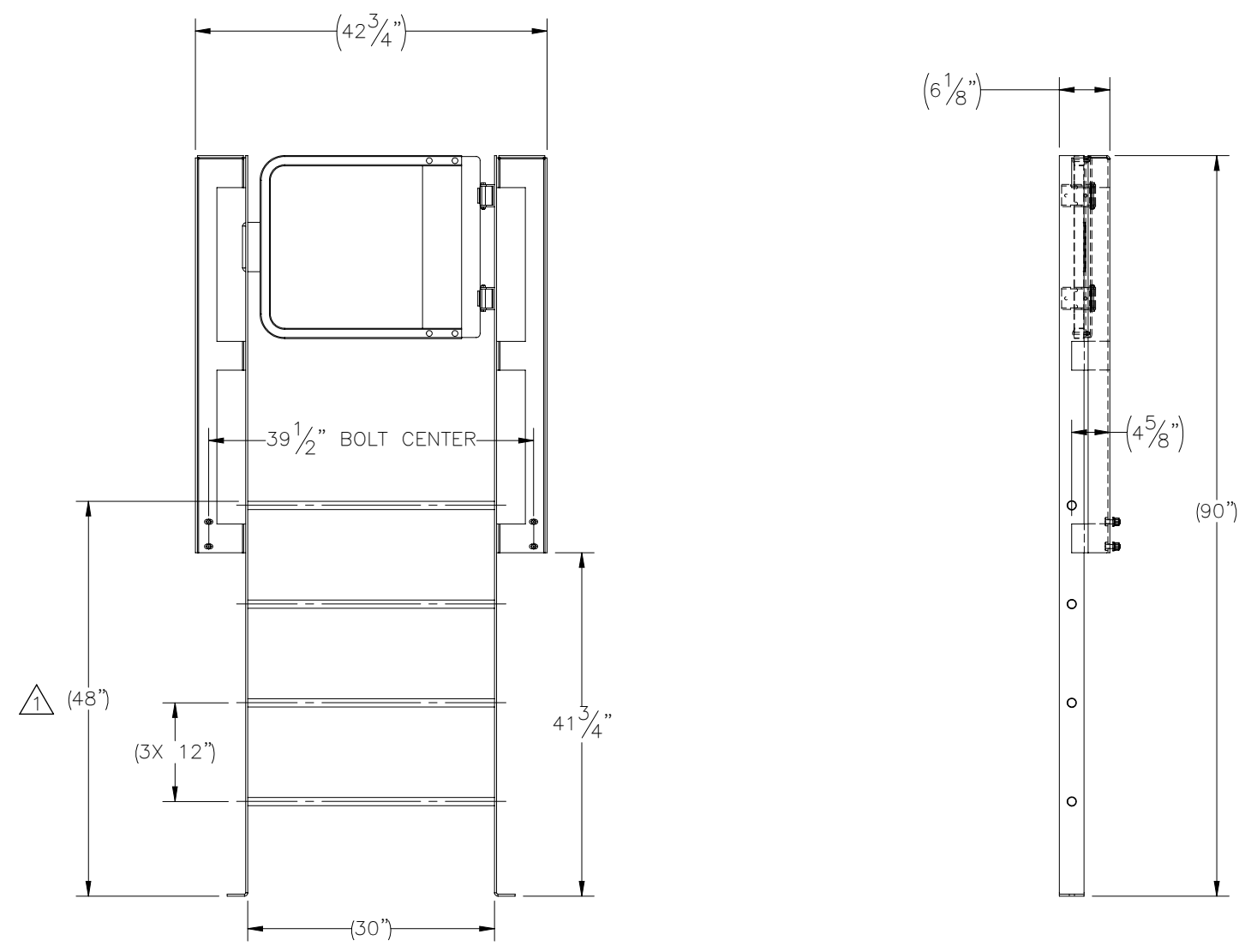

| ITEM NO. | QTY REQD | PART NUMBER | DESCRIPTION | LENGTH | WEIGHT |
|----------|----------|--------------|--|--------|--------|
| 1 | 1 | W-002-509 | 48" LADDER WELDMENT | | 112.28 |
| 2 | 1 | 002-SFG-0002 | LADDER SAFETY GATE, YELLOW | | |
| 3 | 4 | 002-OBG-0010 | BOLT, HX. HD., .500-13UNC X 1.50 LG., PARTIAL THD., ASTM A325, GALV. | | 0.14 |
| 4 | 4 | 002-ONG-0010 | NUT, HEX, .500-13UNC, GR 2H, GALV | | 0.06 |
| 5 | 4 | 002-OLW-G002 | WASHER, SPLIT LOCK, .500", GALV | | 0.01 |
| 6 | 4 | 002-OFW-G002 | FW, .50, F436, HDG | | 0.02 |

NOTE:
FALL PROTECTION GATE TO BE FIELD DRILLED AND INSTALLED.

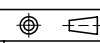
| | | | | | | | | | |
|--|--|---|--|-------------------------|--|------------|--|--|--|
| SURFACE FINISH <input checked="" type="checkbox"/> UNLESS OTHERWISE SPECIFIED | | UNLESS OTHERWISE SPECIFIED DIMENSIONS ARE IN INCHES | | APPROVALS | | DATE | |  ELECTRO MECHANICAL INDUSTRIES, INC. 11230 NEESESHAW DRIVE HOUSTON, TEXAS 77065 1-800-453-0050 | |
| MATERIAL SEE PARTS LIST | | TOLERANCES .0 ±.06 .00 ±.015 .000 ±.005 | | DRAWN B. HUTSON | | 10/28/2022 | | TITLE: 48" LADDER ASSEMBLY, 36" WIDE | |
| THIRD ANGLE PROJECTION  | | FRACTIONS ± 1/16 | | CHECKER J. ROACH | | 10/28/2022 | | | |
| NEXT ASSY | | USED ON | | ENGINEER J. Breen | | 10/31/2022 | | | |
| APPLICATIONS | | HOLES: DRILLED OR PUNCHED ± 1/32 | | PRODUCTION J. KERNER | | 10/31/2022 | | SIZE B | |
| | | BURNED ± 1/32 | | | | | | DRAWING NO. 1005-0360-0480 | |
| | | | | | | | | REV 1 | |
| | | | | | | | | SCALE: 1:20 WEIGHT: 115.4 lbs. | |
| | | | | | | | | SHEET 1 OF 1 | |