

THE INFORMATION CONTAINED IN THIS DRAWING IS THE SOLE PROPERTY OF ELECTRO MECHANICAL INDUSTRIES, INC. ANY REPRODUCTION IN PART OR WHOLE WITHOUT THE WRITTEN PERMISSION OF ELECTRO MECHANICAL IND., IS PROHIBITED.

REVISIONS					
REV.	DCN #	DESCRIPTION	DATE	BY	APPROVED
1	01092	002-OBG-0026 TO 002-OBG-0010, W-001-998 AND W-001-999 UPDATED TO CONSOLIDATE WELDS, DIM'S ADDED/CHANGED FOR CONSISTANCY	11/29/21	JTR	JPB

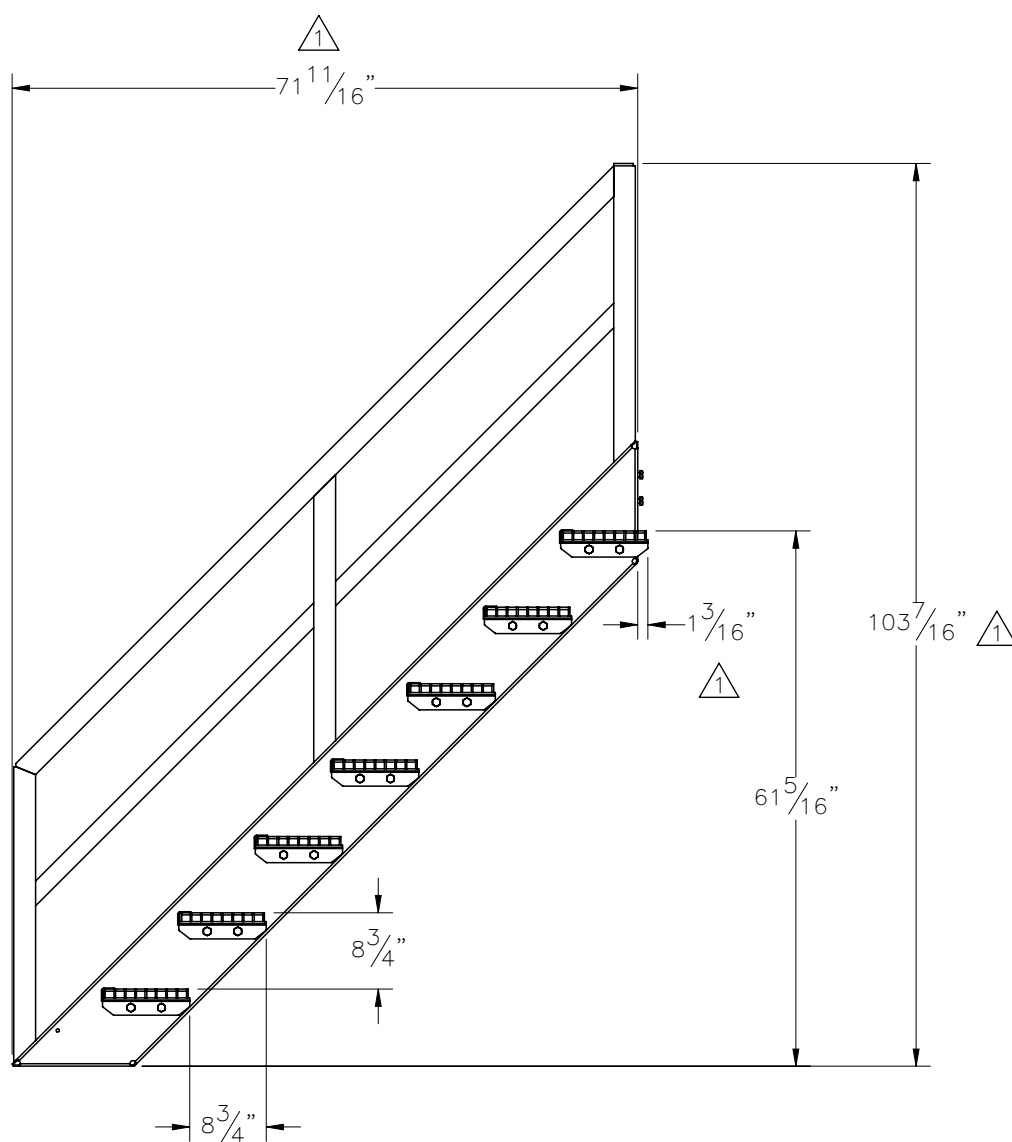

SECTION A-A

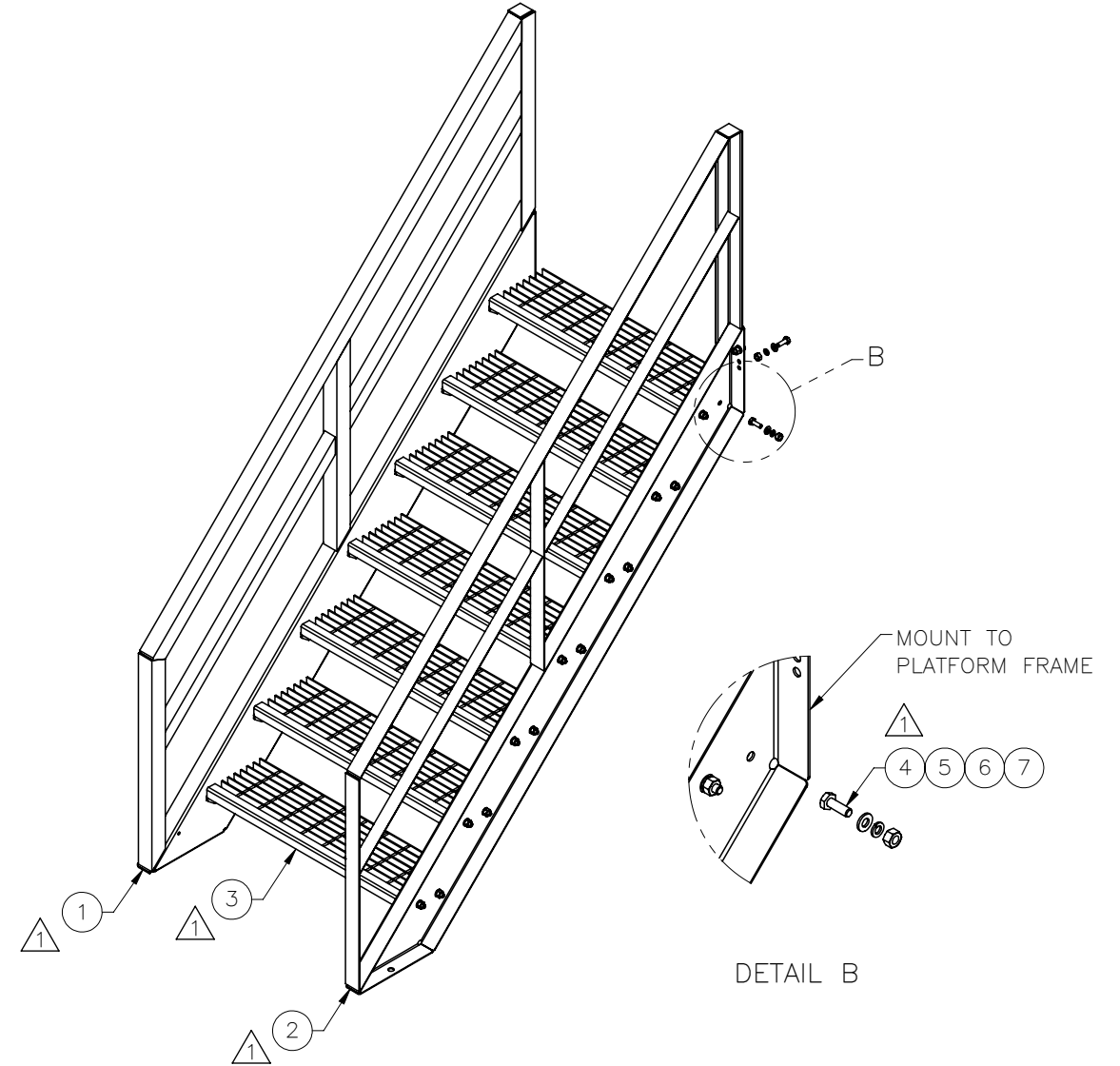
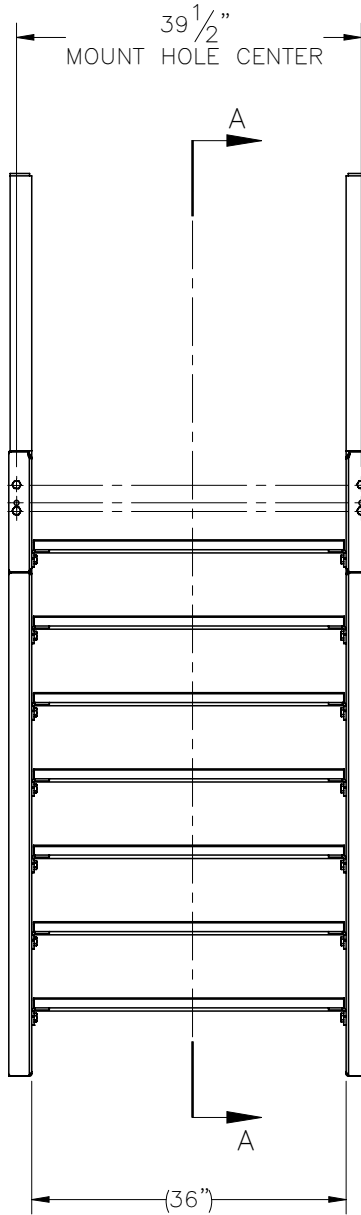

ITEM NO.	PART NUMBER	DESCRIPTION	LENGTH	WEIGHT
1	W-001-998	LEFT SIDE STAIR WELDMENT	123 7/16"	145.0
2	W-001-999	RIGHT SIDE STAIR WELDMENT	123 7/16"	145.0
3	W-001-873	36" WD STAIR TREAD WELDMENT	36	26.16
4	002-OBG-0010	HHB, .500-13 X 1.50 LG., PT X 1.00, A325, HDG	1.50	0.14
5	002-OFW-G002	FW, .50, F436, HDG		0.02
6	002-OLW-G002	WASHER, SPLIT LOCK, .500", GALV		0.01
7	002-ONG-0010	NUT, HEX, .500-13UNC, GR 2H, GALV		0.06

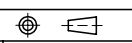
SURFACE FINISH <input checked="" type="checkbox"/> UNLESS OTHERWISE SPECIFIED		UNLESS OTHERWISE SPECIFIED DIMENSIONS ARE IN INCHES		APPROVALS		DATE		 ELECTRO MECHANICAL INDUSTRIES, INC. 11230 NEESESHAW DRIVE HOUSTON, TEXAS 77065 1-800-453-0050	
MATERIAL SEE PARTS LIST		TOLERANCES .0 ±.06 .00 ±.015 .000 ±.005 FRACTIONS ± 1/16 ANGLES ± .25° HOLES: DRILLED OR PUNCHED +1/32 BURNED ±1/32		DRAWN P. GUTIERREZ		10/27/2020			
THIRD ANGLE PROJECTION 		NEXT ASSY		USED ON		CHECKER J. BREEN		10/27/2020	
APPLICATIONS		PRODUCTION J.K.S.		10/27/2020		SIZE B		DRAWING NO. 450-000-0152	
						SCALE: 1:22		WEIGHT: 480.8 lbs.	
								REV 1	
								SHEET 1 OF 1	