

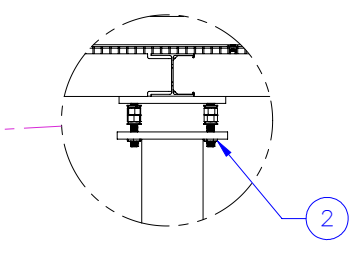

THE INFORMATION CONTAINED IN THIS DRAWING IS THE SOLE PROPERTY OF ELECTRO MECHANICAL INDUSTRIES, INC. ANY REPRODUCTION IN PART OR WHOLE WITHOUT THE WRITTEN PERMISSION OF ELECTRO MECHANICAL IND., IS PROHIBITED.

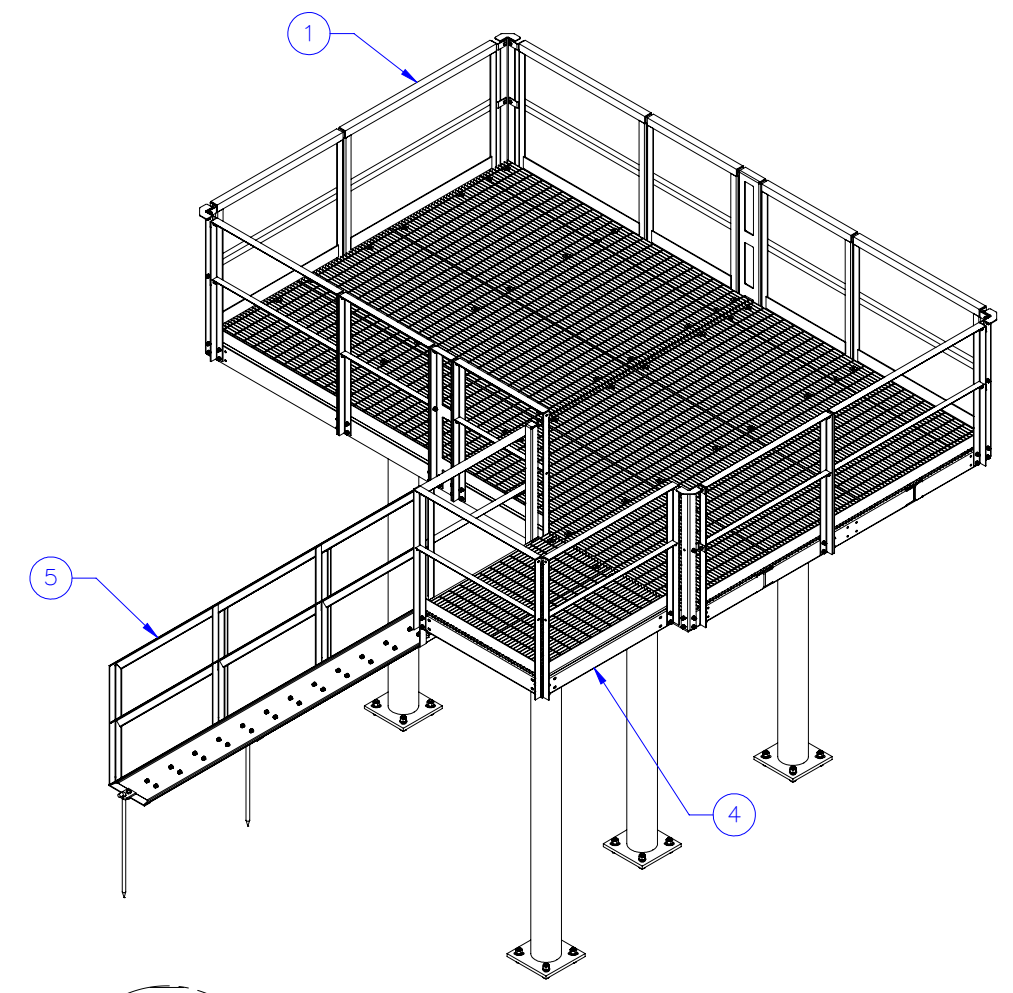
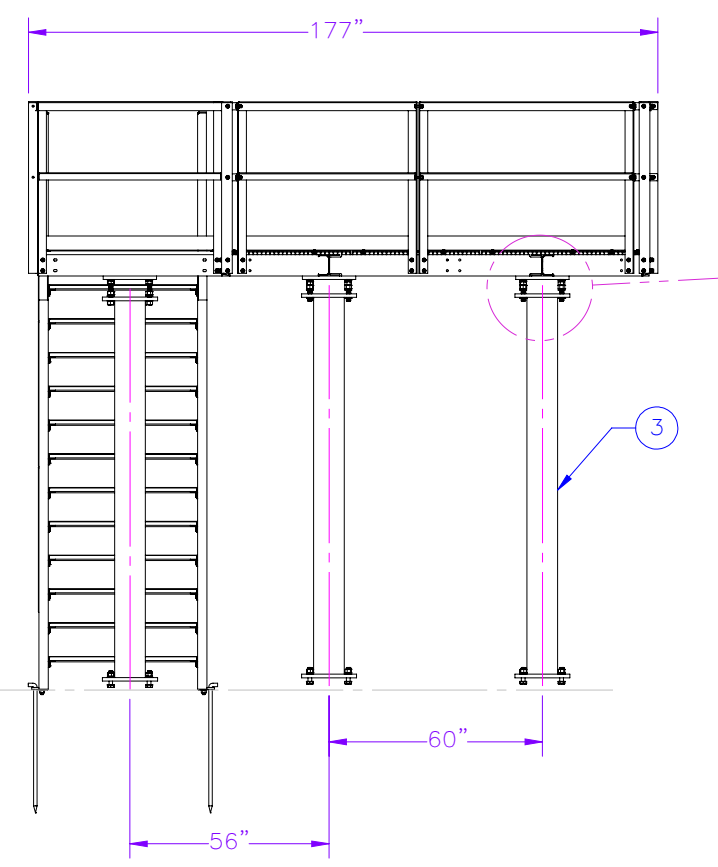
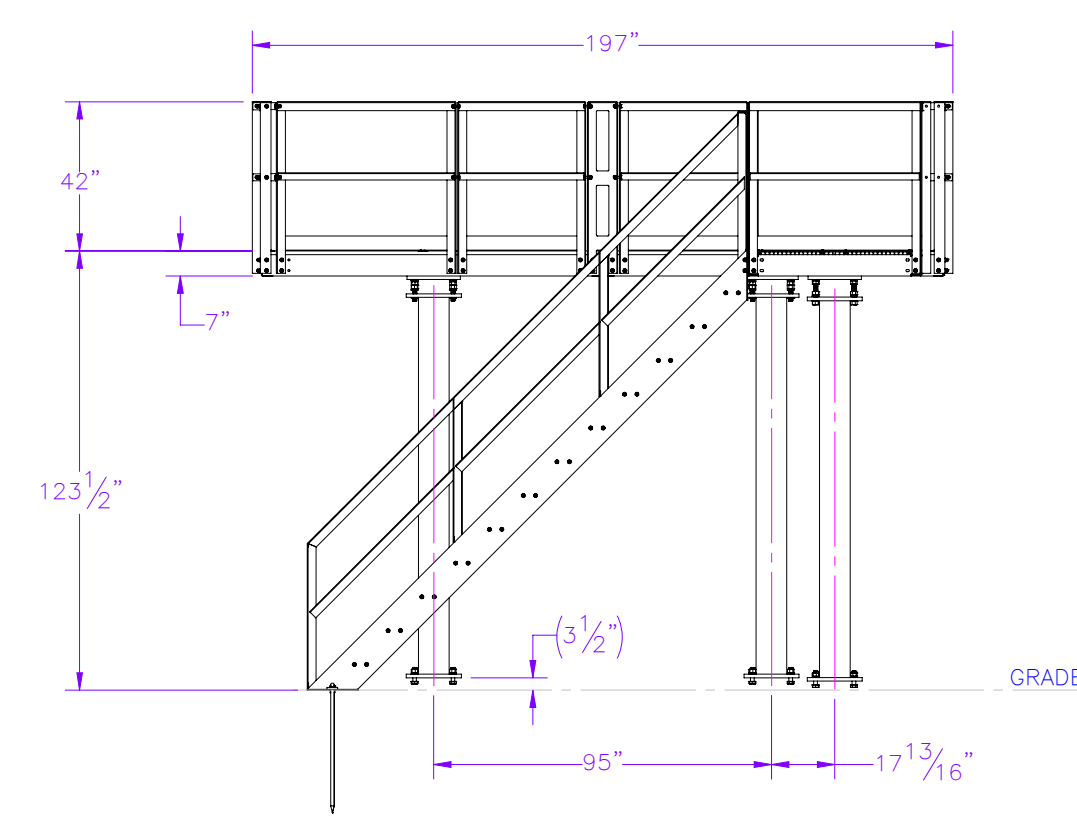
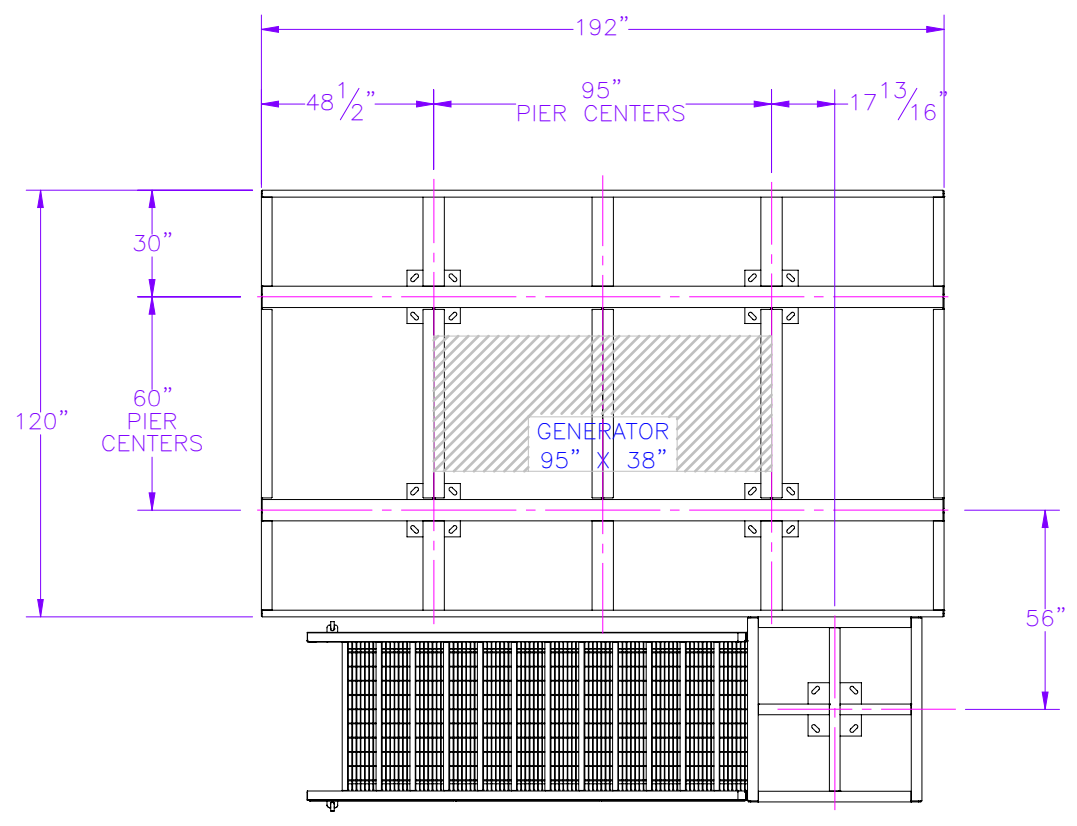

ITEM NO.	QTY.	PART NUMBER	DESCRIPTION	LENGTH	WEIGHT
1	1	1001-0020-0180	10' X 16' GENERATOR PLATFORM		3715.69
2	4	1000-0020-0077	QUAD MOUNT 1" LEVELING HARDWARE KIT		15.17
3	5	1007-TX08-1080	8" X 9.0 FT EXTENSION	108"	374.51
4	1	1003-0030-0006	STAIR LANDING		575.1
5	1	1003-0080-0012	STAIRS, 42" WD, 12 TREAD		581.40

Options:	
Helical Foundation Kit	1000-0030-0253
Ice Bridge Canopy	1001-0030-0105
Crane	1000-0030-0251

SURFACE FINISH <input checked="" type="checkbox"/> UNLESS OTHERWISE SPECIFIED		UNLESS OTHERWISE SPECIFIED DIMENSIONS ARE IN INCHES		APPROVALS		DATE		 ELECTRO MECHANICAL INDUSTRIES, INC. 11230 NEESEHAW DRIVE HOUSTON, TEXAS 77065 1-800-453-0050	
MATERIAL SEE PARTS LIST		TOLERANCES		DRAWN		3/26/2025			
THIRD ANGLE PROJECTION 		.0 ±.06 .00 ±.015 .000 ±.005		F. BAYEH				TITLE: 10' X 16' GENERATOR PLATFORM ASSEMBLY, STAIR, 10' ELEV.	
NEXT ASSY		FRACTIONS ± 1/16 ANGLES: FORMED ± 1°, ALL OTHERS ± .25° HOLES: DRILLED OR PUNCHED +1/32, BURNED ±1/32		CHECKER					
APPLICATIONS				ENGINEER/DESIGNER				SCALE: 1:54 WEIGHT: 6805.43 lbs. SHEET 1 OF 2	

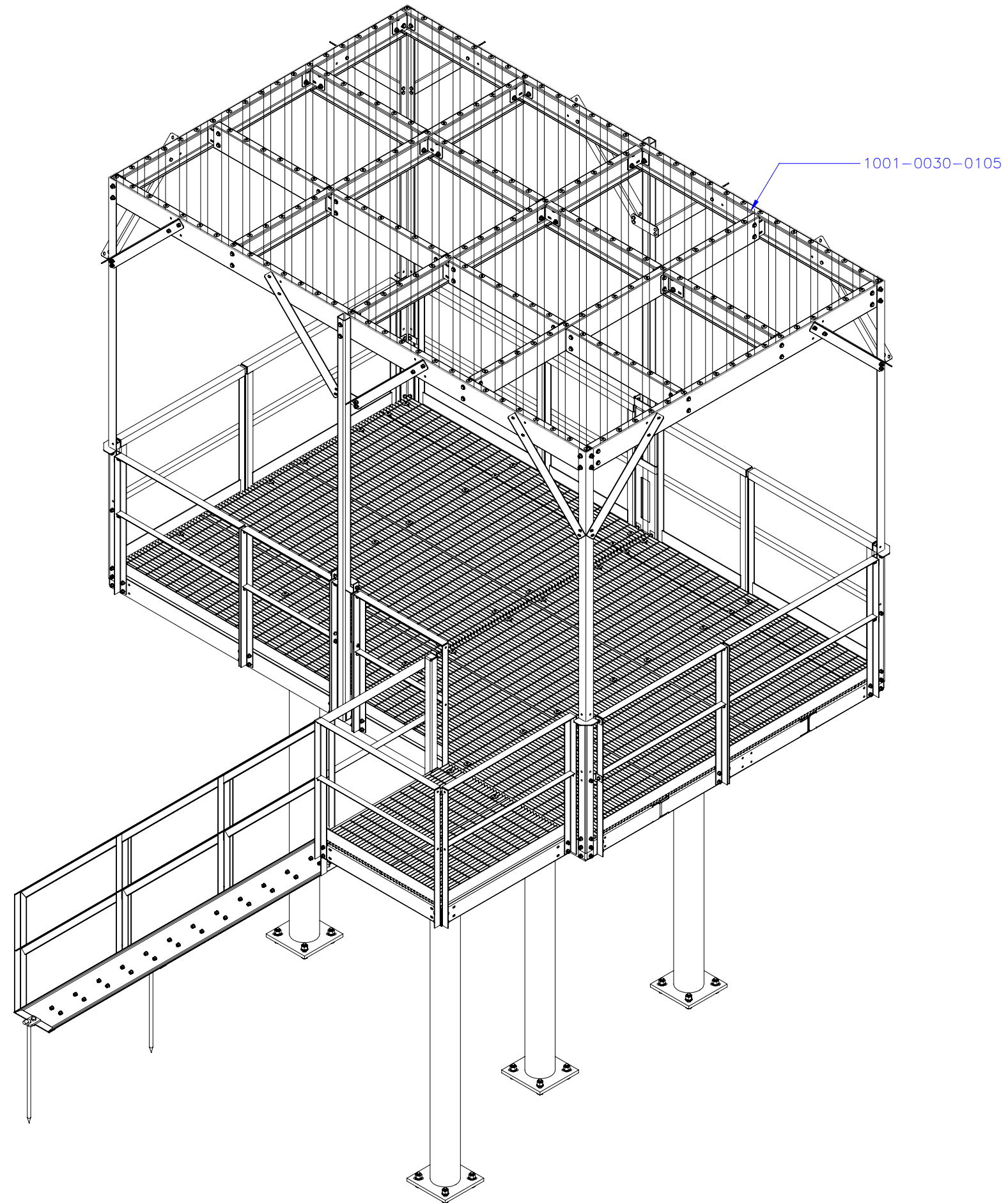

		ELECTRO MECHANICAL INDUSTRIES, INC. 11230 NEESHAW DRIVE HOUSTON, TEXAS 77065 1-800-453-0050	
SIZE	DRAWING NO.	REV	
B	1000-0010-0567-10	0	
SCALE: 1:96		SHEET 2 OF 2	